

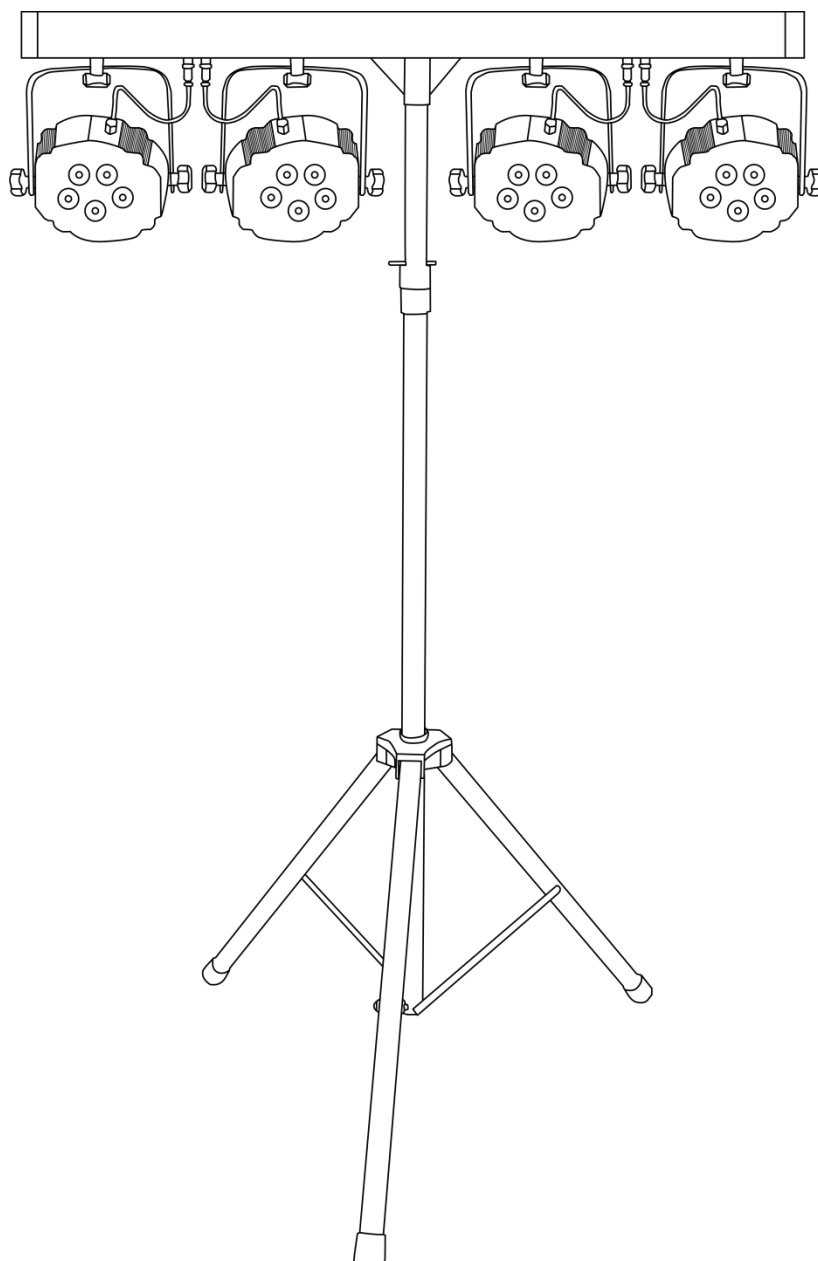

# MANUAL



ENGLISH

## Compact Power Lightset 4 RGBW V1

Ordercode: 30277

**Table of contents**

**Warning**..... 2  
 Safety Instructions..... 2  
 Operating Determinations ..... 4  
 Rigging..... 4  
 Connection with the mains..... 4  
 Return Procedure..... 5  
 Claims..... 5

**Description of the device** ..... 6  
 Optional accessories ..... 6  
 Backside..... 7

**Installation**..... 7

**Set Up and Operation** ..... 7  
 Control Modes..... 7  
 One Compact Power Lightset 4 RGBW (Sound-control) ..... 8  
 One Compact Power Lightset 4 RGBW (Manual control) ..... 8  
 One Compact Power Lightset 4 RGBW (Auto Run, Built-in programs)..... 8  
 Multiple Compact Power Lightsets 4 RGBW (Master/Slave control)..... 8  
 Multiple Compact Power Lightsets 4 RGBW (DMX512 Mode)..... 9  
 Fixture Linking ..... 10  
 Data Cabling..... 10  
 Control Panel..... 11  
 DMX Control Mode..... 11  
 DMX Addressing ..... 11

**Menu overview**..... 12  
 Main Menu Options ..... 13  
 1. DMX Mode..... 13  
 2. Built-in Programs..... 13  
 3. Auto Run Program ..... 14  
 4. Info ..... 14  
 5. Settings ..... 14  
 6. Sound control Mode..... 15  
 7. Manual Mode (Static color mode)..... 16  
 8. Slave Mode..... 16  
 Footswitch..... 16  
 DMX Channels..... 17  
 4 channels..... 17  
 5 channels..... 17  
 6 channels..... 19  
 8 channels..... 20  
 10 channels..... 21  
 16 channels..... 23  
 19 channels..... 25

**Maintenance**..... 27  
 Replacing a Fuse..... 27

**Troubleshooting** ..... 27  
 No Light..... 27  
 No Response to DMX ..... 28

**Product Specifications** ..... 29

**Dimensions** ..... 30

## Warning



**For your own safety, please read this user manual carefully  
before your initial start-up!**



## Unpacking Instructions

Immediately upon receiving this product, carefully unpack the carton and check the contents to ensure that all parts are present, and have been received in good condition. Notify the dealer immediately and retain packing material for inspection if any parts appear to be damaged from shipping or the carton itself shows signs of mishandling. Save the carton and all packing materials. In the event that the fixture must be returned to the factory, it is important that the fixture be returned in the original factory box and packing.

## Your shipment includes:

- Showtec Compact Power Lightset 4 RGBW
- Stand, T-bar, carrying bag and hard case incl.
- IEC powercable 5,0m
- 2 safety eyes
- User manual

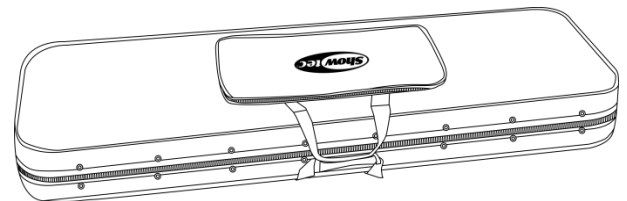
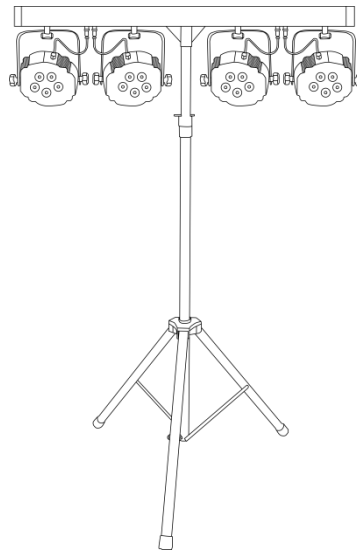

## LED Expected Lifespan

LEDs gradually decline in brightness over time. HEAT is the dominant factor that leads to the acceleration of this decline. Packaged in clusters, LEDs exhibit higher operating temperatures than in ideal or singular optimum conditions. For this reason when all color LEDs are used at their fullest intensity, life of the LEDs is significantly reduced. If improving the lifespan is of higher priority, place care in providing for lower operational temperatures. This may include climatic-environmental and the reduction of overall projection intensity



### CAUTION!

**Keep this device away from rain and moisture!  
Unplug mains lead before opening the housing!**



## Safety Instructions

Every person involved with the installation, operation and maintenance of this device has to:

- be qualified
- follow the instructions of this manual



**CAUTION! Be careful with your operations.  
With a dangerous voltage you can suffer  
a dangerous electric shock when touching the wires!**



Before your initial start-up, please make sure that there is no damage caused by transportation. Should there be any, consult your dealer and do not use the device.

To maintain perfect condition and to ensure a safe operation, it is absolutely necessary for the user to follow the safety instructions and warning notes written in this manual.

Please consider that damages caused by manual modifications to the device are not subject to warranty. This device contains no user-serviceable parts. Refer servicing to qualified technicians only.

### **IMPORTANT:**

The manufacturer will not accept liability for any resulting damages caused by the non-observance of this manual or any unauthorized modification to the device.

- Never let the power cord come into contact with other cables! Handle the power cord and all connections with the mains with particular caution!
- Never remove warning or informative labels from the unit.
- Never use anything to cover the ground contact.
- Never place any material over the lens.
- Never look directly into the light source.
- Never leave any cables lying around.
- Do not insert objects into air vents.
- Do not connect this device to a dimmerpack.
- Do not switch the device on and off in short intervals, as this would reduce the device's lifespan.
- Do not touch the device's housing bare-handed during its operation. Allow the fixture to cool for at least 5 minutes before handling.
- Do not shake the device. Avoid brute force when installing or operating the device.
- Only use device indoor, avoid contact with water or other liquids.
- Only operate the fixture after having checked that the housing is firmly closed and all screws are tightly fastened.
- Only operate the device after having familiarized with its functions.
- Avoid flames and do not put close to flammable liquids or gases.
- Always keep case closed while operating.
- Always allow free air space of at least 50 cm around the unit for ventilation.
- Always disconnect power from the mains, when device is not used or before cleaning! Only handle the power cord by the plug. Never pull out the plug by tugging the power cord.
- Make sure that the device is not exposed to extreme heat, moisture or dust.
- Make sure that the available voltage is not higher than stated on the rear panel.
- Make sure that the power cord is never crimped or damaged. Check the device and the power cord from time to time.
- If the lens is obviously damaged, it has to be replaced to prevent its functions from being impaired, due to cracks or deep scratches.
- If device was dropped or struck, disconnect mains power supply immediately. Have a qualified engineer inspect for safety before operating.
- If the device has been exposed to drastic temperature fluctuation (e.g. after transportation), do not switch it on immediately. The arising condensation water might damage your device. Leave the device switched off until it has reached room temperature.
- If your Showtec device fails to work properly, discontinue use immediately. Pack the unit securely (preferably in the original packing material), and return it to your Showtec dealer for service.
- For adult use only. Device must be installed out of reach of children. Never leave the unit running unattended.
- Never attempt to bypass the thermostatic switch or fuses.
- For replacement, use fuses of same type and rating only.
- The user is responsible for correct positioning and operating of the Compact Power Lightset 4 RGBW. The manufacturer will not accept liability for damages caused by the misuse or incorrect installation of this device.
- This device falls under protection class I. Therefore it is essential to connect the yellow/green conductor to earth.
- Repairs, servicing and electrical connection must be carried out by a qualified technician.
- **WARRANTY:** Till one year after date of purchase.



**CAUTION! Eyedamages!!!**  
**Avoid looking directly into the lightsource!!!**  
**(meant especially for epileptics)!!!**



## Operating Determinations

- This device is not designed for permanent operation. Regular operation breaks will ensure that the device will serve you for a long time without defects.
- The minimum distance between light-output and the illuminated surface must be bigger than 1 meter.
- The maximum ambient temperature  $t_a = 40^\circ\text{C}$  must never be exceeded.
- The relative humidity must not exceed 50 % with an ambient temperature of  $40^\circ\text{C}$ .
- If this device is operated in any other way than the one described in this manual, the product may suffer damages and the warranty becomes void.
- Any other operation may lead to dangers like short-circuit, burns, electric shock, crash etc.

You endanger your own safety and the safety of others!

## Rigging

Please follow the European and national guidelines concerning rigging, trussing and all other safety issues.

*Do not attempt the installation yourself!*

*Always let the installation be carried out by an authorized dealer!*

## Procedure:

- If the Compact Power Lightset 4 RGBW is lowered from the ceiling or high joists, professional trussing systems have to be used.
- Use a clamp to mount the Compact Power Lightset 4 RGBW, with the mounting-bracket, to the trussing system.
- The Compact Power Lightset 4 RGBW must never be fixed swinging freely in the room.
- The installation must always be secured with a safety attachment, e.g. an appropriate safety net or safety-cable.
- When rigging, derigging or servicing the Compact Power Lightset 4 RGBW, always make sure, that the area below the installation place is blocked and staying in the area is forbidden.

The Compact Power Lightset 4 RGBW can be placed on a flat stage floor or mounted to any kind of truss by a clamp.

Improper installation can cause serious injuries and/or damage of property!

## Connection with the mains

Connect the device to the mains with the power plug.

Always check if the right color cable is connected to the right place.

International	EU Cable	UK Cable	US Cable	Pin
L	BROWN	RED	YELLOW/COPPER	PHASE
N	BLUE	BLACK	SILVER	NEUTRAL
	YELLOW/GREEN	GREEN	GREEN	PROTECTIVE GROUND

*Make sure that the device is always connected properly to the earth!*

*Improper installation can cause serious damage to people and property!*



### Return Procedure



Returned merchandise must be sent prepaid and in the original packing, call tags will not be issued. Package must be clearly labeled with a Return Authorization Number (RMA number). Products returned without an RMA number will be refused. Highlite will not accept the returned goods or any responsibility. Call Highlite 0031-455667723 or mail [aftersales@highlite.nl](mailto:aftersales@highlite.nl) and request an RMA prior to shipping the fixture. Be prepared to provide the model number, serial number and a brief description of the cause of the return. Be sure to properly pack fixture as any shipping damage resulting from inadequate packaging is the customer's responsibility. Highlite reserves the right to use its own discretion to repair or replace product(s). As a suggestion, proper UPS packing or double-boxing is always a safe method to use.

**Note: If you are given an RMA number, please include the following information on a piece of paper inside the box:**

- 01) Your name.
- 02) Your address.
- 03) Your phone number.
- 04) A brief description of the symptoms.

### Claims

The client has the obligation to check the delivered goods immediately upon delivery for any short-comings and/or visible defects, or perform this check after our announcement that the goods are at their disposal. Damage incurred in shipping is the responsibility of the shipper; therefore the damage must be reported to the carrier upon receipt of merchandise.

It is the customer's responsibility to notify and submit claims with the shipper in the event that the fixture is damaged due to shipping. Transportation damage has to be reported to us within one day after receipt of the delivery.

Any return shipment has to be made post-paid at all times. Return shipments must be accompanied with a letter defining the reason for return shipment. Non-prepaid return shipments will be refused, unless agreed otherwise in writing.

Complaints against us must be made known in writing or by fax within 10 working days after receipt of the invoice. After this period, complaints will not be handled anymore.

Complaints will only be considered if the client has so far complied with all parts of the agreement, regardless of the agreement of which the obligation is resulting.

## Description of the device

---

### Features

The Showtec Compact Power Lightset 4 RGBW is a T-bar with 4 LED spots on a light stand, packed in a hard case and a carrying bag for the stand. It is a plug and play set that offers internal chase programs but also can be controlled by DMX or with the optional available footswitch.

- T-Bar with built-in controller
- 4-in-1 RGBW LEDs
- Stand included
- Carrying bag included
- Power Supply: 100-240V AC, 50/60Hz
- Drive current: 330 mA
- Refresh rate: 7,8 KHz
- Control Mode: DMX512
- LED Source: 5x 4-in-1 RGBW LEDs 4W (per spot)
- Dimmer: 0-100%
- Strobe: 0-20Hz
- Beam angle: 25°
- Consumption Power: 90 Watt
- 3 pin female XLR socket and 3 pin male XLR socket
- IEC Power In and Out (10a)
- Linkable via 3-pin XLR cable
- Built-in microphone
- Housing: Black Aluminum and Iron
- LCD display
- Fuse: 5S1.5A / 250V
- Cooling: Aluminum heat sink
- IP rating: IP-20
- Control mode: DMX512, Sound, Stand-alone, Master/slave, Optional footswitch
- Selectable 4, 5, 6, 8, 10, 16 and 19 DMX channel operation
- Dimensions T-bar + 4 parcans: 845 x 55 x 70 mm (LXWXH)
- Weight T-bar + 4 parcans: 7,3 kg

**Note:** Knowledge of DMX is required to fully utilize this unit.

### Optional accessories

[30267](#) Footswitch

[D7026](#) Case for 4X compact lightsets

## Backside

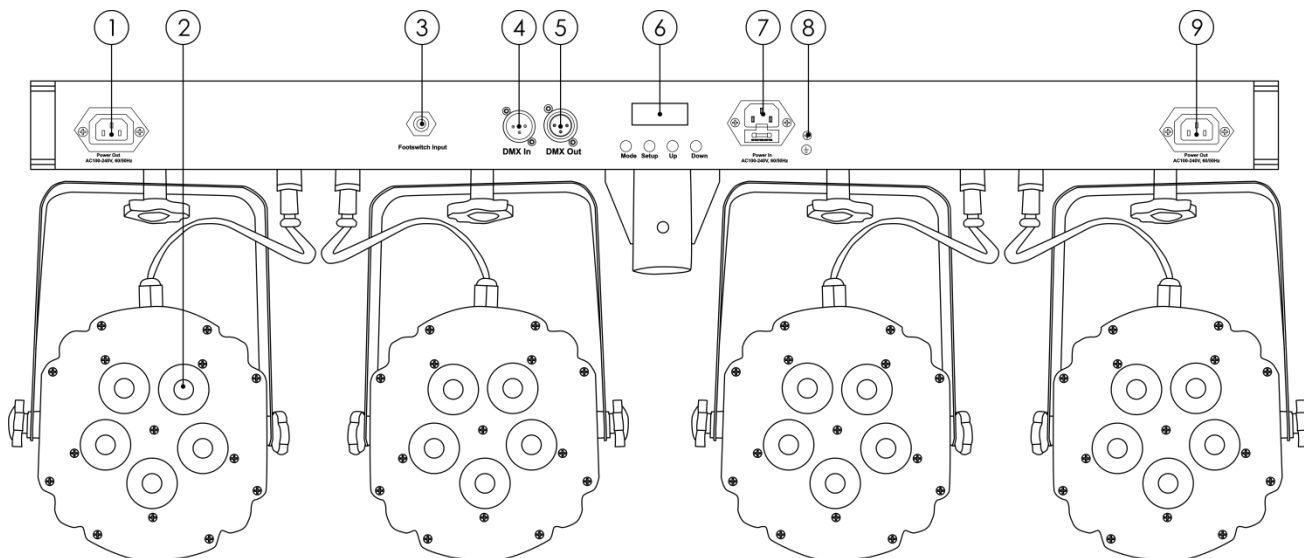

Fig. 01

- 01) IEC Power Out (10a)
- 02) 5x 4-in-1 RGBW LEDs 4W (per spot)
- 03) Footswitch input
- 04) DMX signal connector (IN) 3-pin
- 05) DMX signal connector (OUT) 3-pin
- 06) Menu Buttons + LCD display
- 07) IEC Power In + Fuse: 5S1.5A / 250V
- 08) Ground/Earth connection
- 09) IEC Power Out (10a)

## Installation

Remove all packing materials from the Compact Power Lightset 4 RGBW.

Check that all foam and plastic padding is removed. Connect all cables.

**Do not supply power before the whole system is set up and connected properly.**

**Always disconnect from electric mains power supply before cleaning or servicing.**

**Damages caused by non-observance are not subject to warranty.**

## Set Up and Operation

Follow the directions below, as they pertain to your preferred operation mode.

Before plugging the unit in, always make sure that the power supply matches the product specification voltage. Do not attempt to operate a 120V specification product on 230V power, or vice versa.

Connect the device to the main power supply.

### Control Modes

There are 6 modes:

- Sound-controlled
- Manual mode (Static)
- Auto Run
- Built-in Programs
- Master/Slave
- DMX-512 (4, 5, 6, 8, 10, 16, 19CH)





## One Compact Power Lightset 4 RGBW (Sound-control)

- 01) Fasten the effect light onto firm trussing or place it on the floor. Leave at least 0,5 meter on all sides for air circulation.
- 02) When the Compact Power Lightset is not connected by a DMX-cable, it functions as a stand-alone device.
- 03) Turn on the music. If device is set to  (Audio), then the fixture will react to the beat of the music. Please see page 13 for more information about the Sound-controlled mode.

## One Compact Power Lightset 4 RGBW (Manual control)

- 01) Fasten the effect light onto firm trussing or place it on the floor. Leave at least 0,5 meter on all sides for air circulation.
- 02) When the Compact Power Lightset is not connected by a DMX-cable, it functions as a stand-alone device.
- 03) If device is set to , then the fixture can be manually controlled.
- 04) Please see page 13 for more information about the Manual control mode.

## One Compact Power Lightset 4 RGBW (Auto Run, Built-in programs)

- 01) Fasten the effect light onto firm trussing or place it on the floor. Leave at least 0,5 meter on all sides for air circulation.
- 02) When the Compact Power Lightset is not connected by a DMX-cable, it functions as a stand-alone device.
- 03) If device is set to  or , then the fixture will play one of its built-in programs or show its auto run mode. Please see pages 15-16 for more information about the built-in programs or auto run mode.

## Multiple Compact Power Lightsets 4 RGBW (Master/Slave control)

- 01) Fasten the effect light onto firm trussing or place it on the floor. Leave at least 0,5 meter on all sides for air circulation.
- 02) Plug the end of the electric mains power cord into a proper electric power supply socket.
- 03) Use a 3-p XLR cable to connect the Compact Power Lightsets and other devices.

The pins:



1. Earth
2. Signal (-)
3. Signal (+)

- 04) Link the units as shown in Fig. 02, connect a DMX signal cable from the first unit's DMX "out" socket to the second unit's "in" socket. Repeat this process to link the second and third units. You can use the same functions on the master device as described on pages 13-16 (Sound controlled, Manual control, Auto run, Built-in Programs). This means you can set your desired operation mode on the master device and all slave devices will react the same as the master device.

## Multiple Compact Power Lightsets 4 RGBW (Master/Slave control)

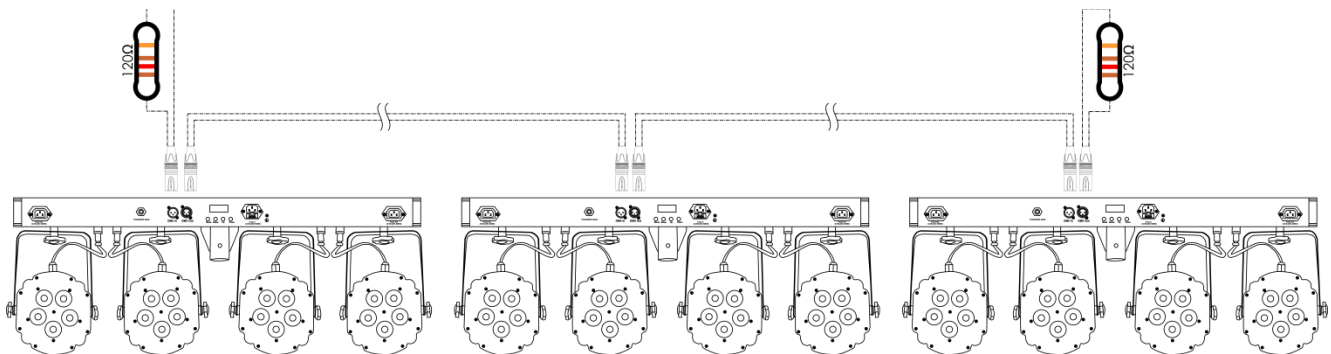
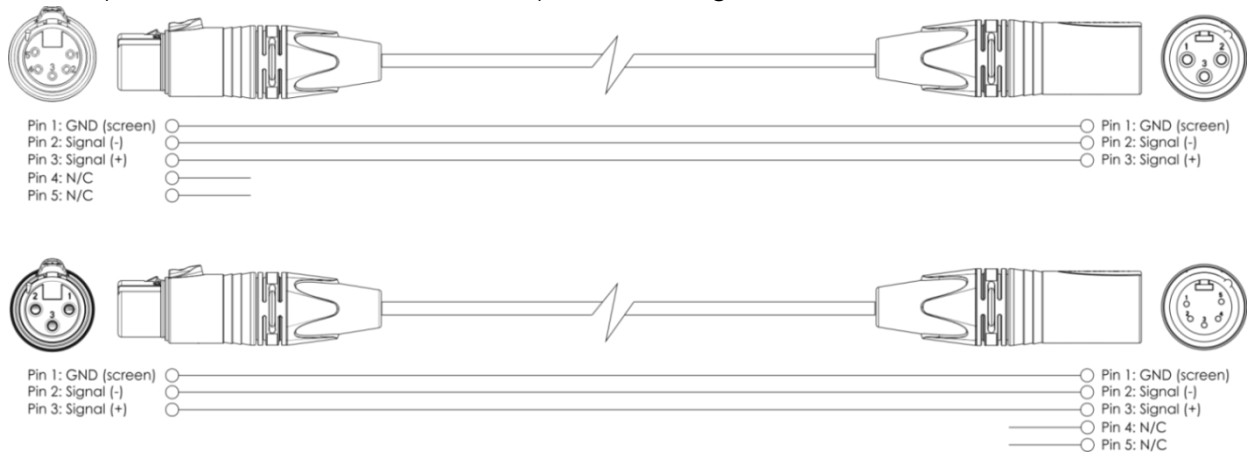

Fig. 02

## Multiple Compact Power Lightsets 4 RGBW (DMX512 Mode)

- 01) Fasten the effect light onto firm trussing or place it on the floor. Leave at least 0,5 meter on all sides for air circulation.
- 02) Plug the end of the electric mains power cord into a proper electric power supply socket.
- 03) Use a 3-p XLR cable to connect the Compact Power Lightsets and other devices.



- 04) Link the units as shown in Fig. 03, Connect a DMX signal cable from the first unit's DMX "out" socket to the second unit's "in" socket. Repeat this process to link the second and third units.
- 05) Supply electric power: Plug electric mains power cords into each unit's IEC socket, then plug the other end of the mains power cord into proper electric power supply sockets, starting with the first unit. Do not supply power before the whole system is set up and connected properly.

## Multiple Compact Power Lightsets 4 RGBW DMX Set Up

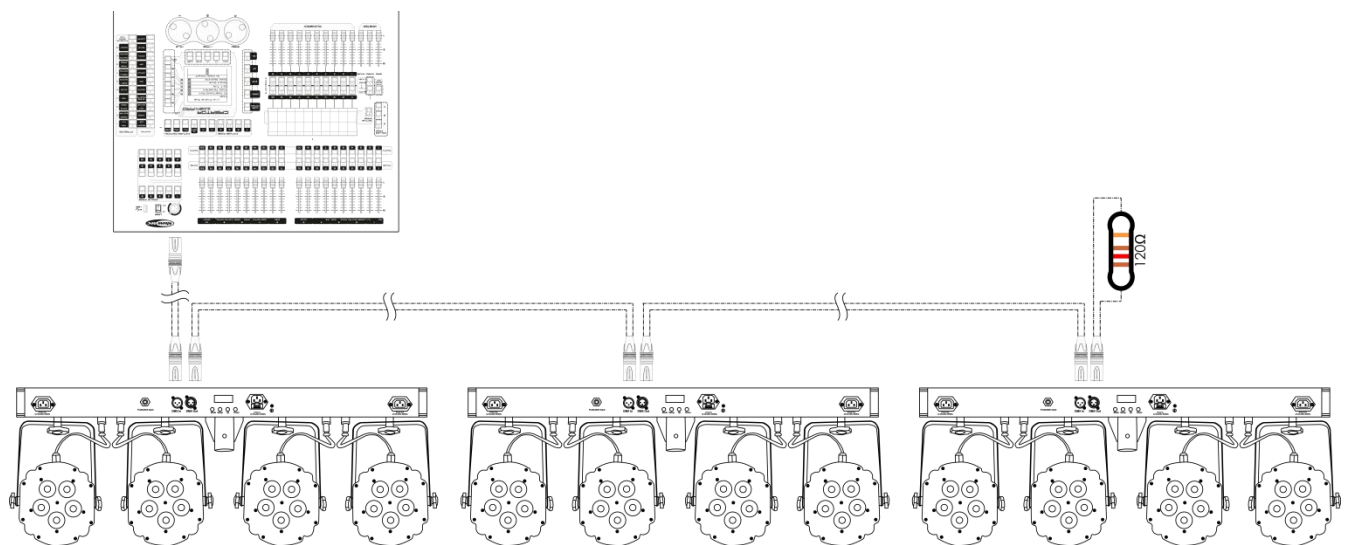

Fig. 03

**Note: Link all cables before connecting electric power!**

### Fixture Linking

You will need a serial data link to run light shows of one or more fixtures using a DMX-512 controller or to run synchronized shows on two or more fixtures set to a master/slave operating mode. The combined number of channels required by all the fixtures on a serial data link determines the number of fixtures the data link can support.

The Compact Power Lightsets 4 RGBW uses up to 19 channels.

**Important:** Fixtures on a serial data link must be daisy-chained in a single line. To comply with the EIA-485 standard, no more than 30 devices should be connected on one data link. Connecting more than 30 fixtures on one serial data link without the use of a DMX optically isolated splitter may result in deterioration of the digital DMX signal.



Maximum recommended DMX data link distance: 100 meters  
Maximum recommended number of fixtures on a DMX data link: 30 fixtures

### Data Cabling

To link fixtures together you must obtain data cables. You can purchase DAP Audio certified DMX cables directly from a dealer/distributor or construct your own cable. If you choose to create your own cable please use data-grade cables that can carry a high quality signal and are less prone to electromagnetic interference.

#### DAP Audio DMX Data Cables

- DAP Audio Basic microphone cable for allround use. bal. XLR/M 3-pin > XLR/F 3-pin. **Ordercode** FL01150 (1,5 m), FL013 (3 m), FL016 (6 m), FL0110 (10 m), FL0115 (15 m), FL0120 (20 m).
- DAP Audio X-type data cable XLR/M 3-pin > XLR/F 3-pin. **Ordercode** FLX0175 (0,75 m), FLX01150 (1,5 m), FLX013 (3 m), FLX016 (6 m), FLX0110 (10 m).
- DAP Audio cable for the demanding user with exceptional audio-qualities and connector made by Neutrik®. **Ordercode** FL71150 (1,5 m), FL713 (3 m), FL716 (6 m), FL7110 (10 m).
- DAP Audio cable for the demanding user with exceptional audio-qualities and connector made by Neutrik®. **Ordercode** FL7275 (0,75 m), FL72150 (1,5 m), FL723 (3 m), FL726 (6 m), FL7210 (10 m).
- DAP Audio 110 Ohm cable with digital signal transmission. **Ordercode** FL0975 (0,75 m), FL09150 (1,5 m), FL093 (3 m), FL096 (6 m), FL0910 (10 m), FL0915 (15 m), FL0920 (20 m).
- DAP Audio DMX adapter: 3-pin/5-pin. **Ordercode** FLA30.

## Control Panel

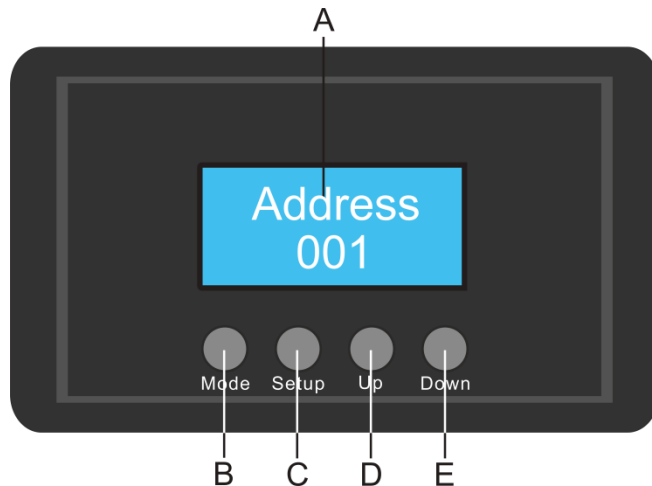

- A. LCD Display
- B. Mode button
- C. Setup Button
- D. Up Button
- E. Down Button

Fig. 04

## DMX Control Mode

The fixtures are individually addressed on a data-link and connected to the controller. The fixtures respond to the DMX signal from the controller. (When you select the DMX address and save it, the controller will display the saved DMX address the next time.)

## DMX Addressing

The control panel on the backside of the device allows you to assign the DMX fixture address, which is the first channel from which the Compact Power Lightset 4 RGBW will respond to the controller. Please note when you use the controller, the unit has up to **19** channels. When using multiple Compact Power Lightsets 4 RGBW, make sure you set the DMX addresses right. Therefore, the DMX address of the first Compact Power Lightset 4 RGBW should be **1(001)**; the DMX address of the second Compact Power Lightset 4 RGBW should be **1+19=20 (020)**; the DMX address of the third Compact Power Lightset 4 RGBW should be **20+19=39 (039)**, etc. Please, be sure that you do not have any overlapping channels in order to control each Compact Power Lightset 4 RGBW correctly. If two or more Compact Power Lightsets 4 RGBW are addressed similarly, they will work similarly.

## Controlling:

After having addressed all Compact Power Lightsets 4 RGBW, you may now start operating these via your lighting controller.

**Note:** After switching on, the Compact Power Lightset 4 RGBW will automatically detect whether DMX 512 data is received or not. The problem may be:

- The XLR cable from the controller is not connected with the input of the Compact Power Lightset 4 RGBW.
- The controller is switched off or defective, the cable or connector is defective, or the signal wires are swapped in the input connector.

**Note:** It is necessary to insert a XLR termination plug (with 120 Ohm) in the last fixture in order to ensure proper transmission on the DMX data link.







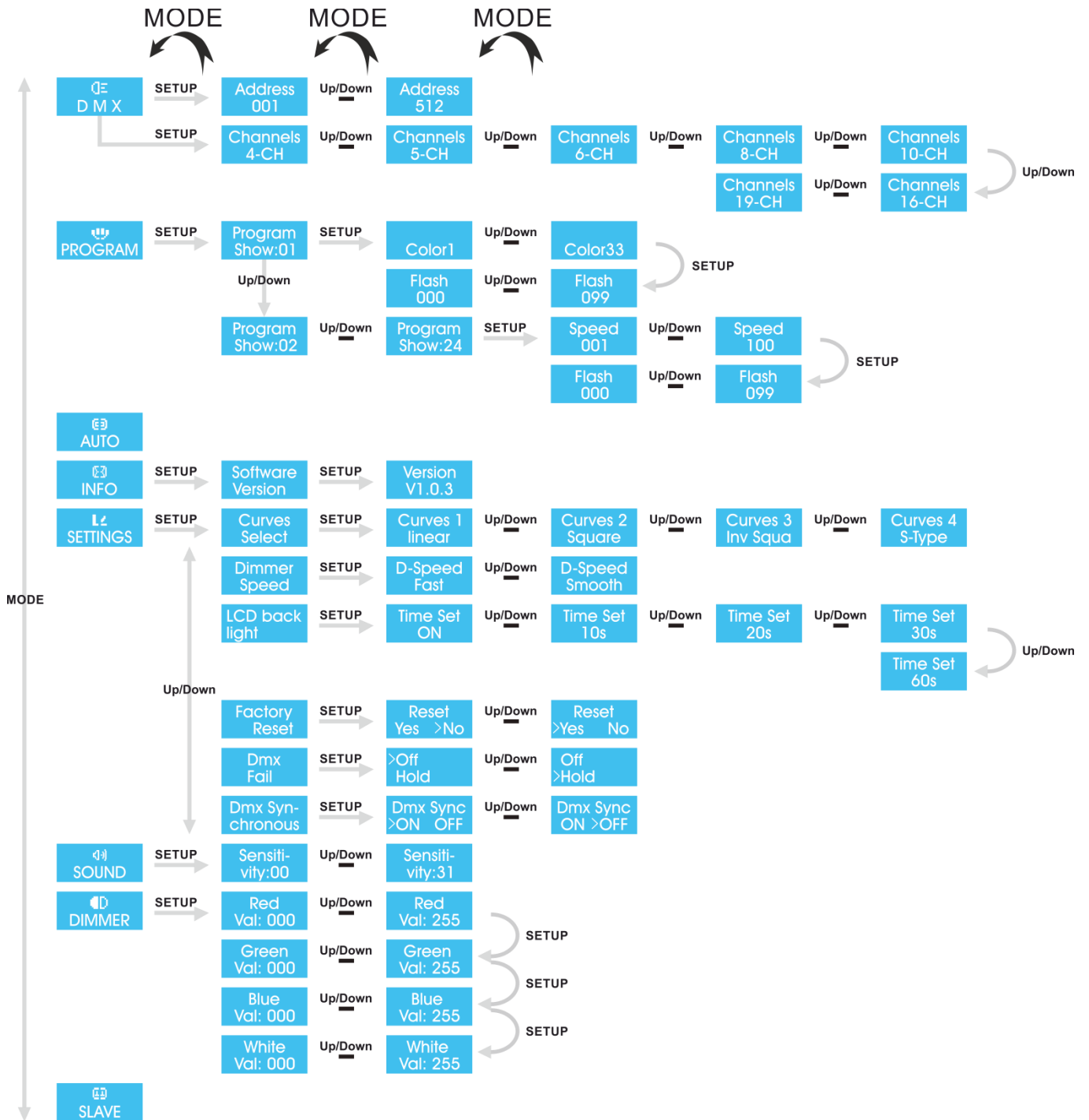

## Display Off after 10 seconds

It is possible to set a time for turning off the display. When no button is pressed for 10, 20, 30 or 60 seconds, the display will turn off. To light up the display, you have to press the Mode, Setup, Up or Down buttons. Once you have pressed the button, the display will light up.

Menu overview



















## Main Menu Options

-  1. DMX mode
-  2. Built in programs
-  3. Auto run
-  4. Info
-  5. Settings
-  6. Sound-controlled mode
-  7. Manual mode (Static color mode)
-  8. Slave mode

### 1. DMX Mode

With this menu you can set the DMX address and choose a DMX configuration.





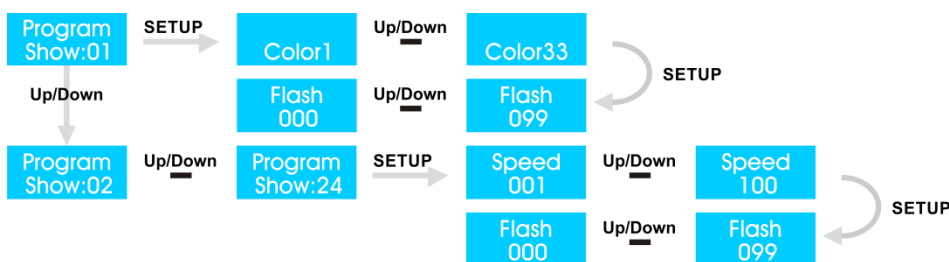

- 01) Press the **Mode** button until the display shows .
  - 02) You can choose 512 different DMX addresses.
  - 03) Use the **Up/Down** buttons to select the required address between   .
  - 04) If you press the **Setup** button, you can choose a different DMX Mode. Select a DMX channel mode between             .
- The display will blink.

### 2. Built-in Programs

With this menu you can choose a built-in program.

- 01) Press the **Mode** button, until the display shows .
- 02) You can choose between 24 built-in programs by using the **Up** and **Down** buttons.
- 03) If you choose  and you press **Setup** you can choose between 33 colors with the **Up/Down** buttons.



- 04) Press **Setup** again and you can set the strobe frequency (    ) by using the **Up/Down** buttons.
- 05) Press the **Mode** button to go back one step.
- 06) With the **Up/Down** buttons you can choose between   .
- 07) Press the **Setup** button to set the speed or strobe frequency from the program.

# Compact Power Lightset 4 RGBW



08) Use the **Up/Down** buttons to set the speed between 001-100 and strobe frequency between 000-099.

### 3. Auto Run Program

With this menu you can activate the Auto run mode of the Compact Power Lightset 4 RGBW.

- 01) Press the **Mode** button on the device until the display shows **AUTO**.
- 02) The Compact Power Lightset 4 RGBW will start automatically with its built-in program.

### 4. Info

With this menu you can view 2 info's about the device.

- 01) Press the **Mode** button until the display shows **INFO**.
- 02) Press the **Setup** button to open the menu.
- 03) Press the **Up/Down** buttons to choose **Software Version**.
- 04) Press the **Setup** button to open the menu.
- 05) You can now see the current software version **Version V1.0.3**.

### 5. Settings

With this menu you can adjust the settings of the device.

- 01) Press the **Mode** button until the display shows **SETTINGS**.
- 02) Press the **Setup** button to open the menu.

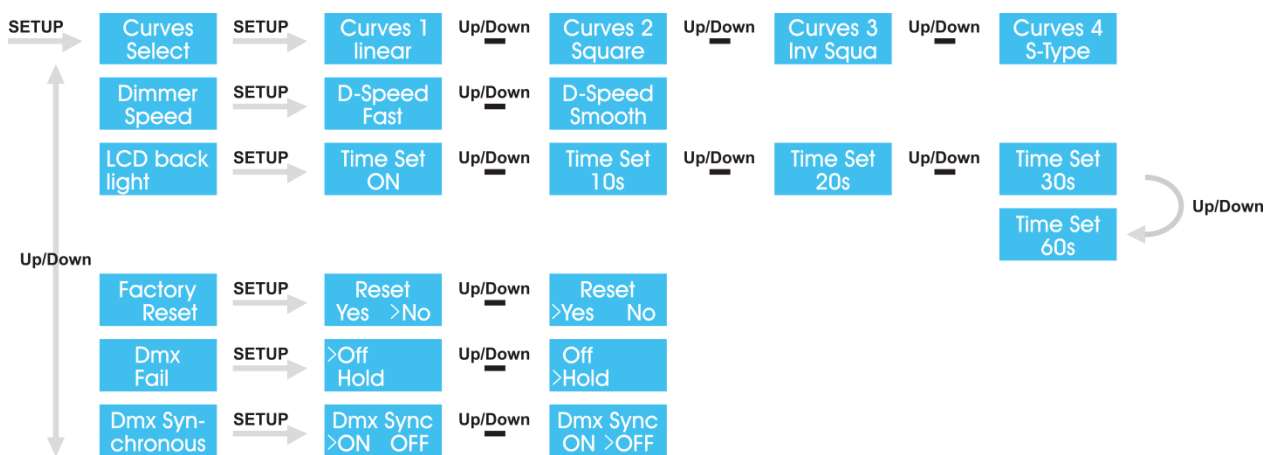

- 03) Press the **Up/Down** buttons to choose between the 6 available options, **Curves Select**, **Dimmer Speed**, **LCD back light**, **Factory Reset**, **Dmx Fail** and **Dmx Synchronous**.
- 04) Press the **Setup** button to open one of the 6 options.
- 05) In the submenu **Curves Select** you can select one of the 4 dimming curves, by pressing the **Up/Down** buttons.

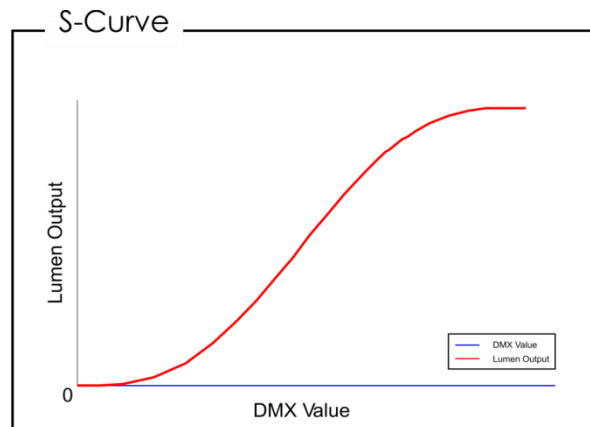
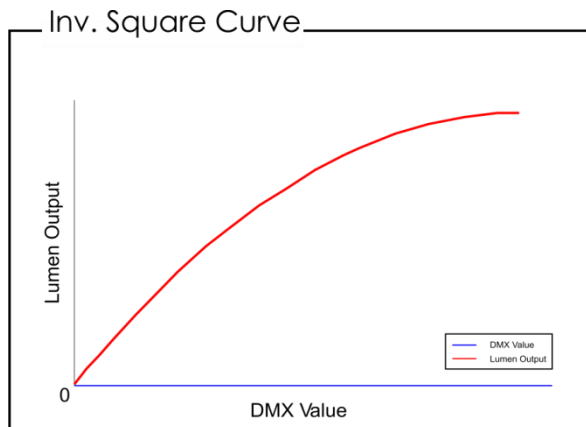
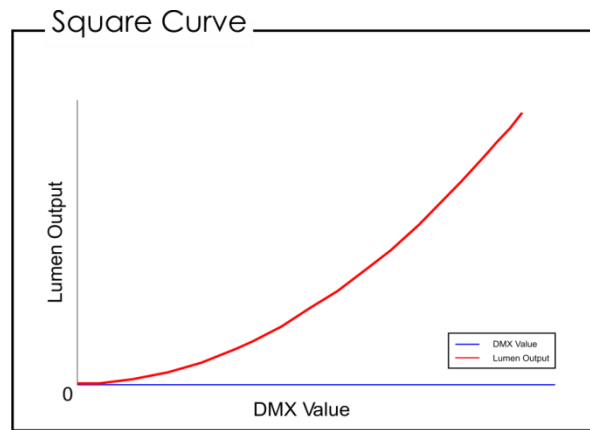
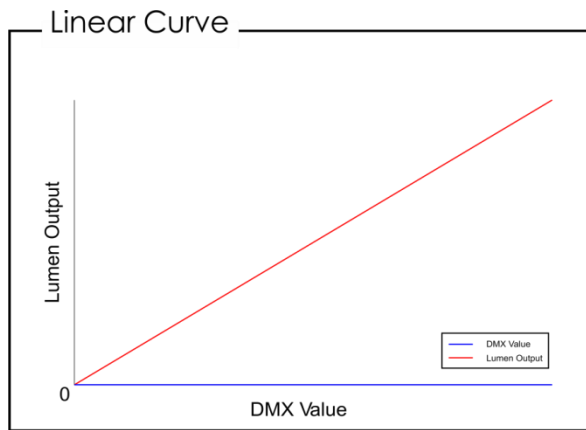

- 06) With the menu option **Dimmer Speed**, you can set the dimmer speed, by pressing the **Up/Down** buttons. You can choose between Smooth or Fast.
- 07) In the menu **LCD back light** you can set how long the display will remain ON, when no button is pressed.
- 08) Press the **Up/Down** buttons to choose between 10, 20, 30 or 60 seconds. If you choose the option "**ON**", the display will remain continuously ON, when no button is pressed.
- 09) The menu option **Factory Reset** is for resetting the device to the factory settings.
- 10) Press the **Setup** button to open the menu and then press the **Up/Down** buttons to choose **Yes** or **No**.
- 11) Press the **Setup** button again to confirm your choice. If you have chosen **Yes**, the factory settings will be restored. The fixture will start up in the Auto Run mode.
- 12) In the menu option **Dmx Fail** you can set the device to **Off** or **Hold**.
- 13) If you choose **Off** the fixture will blackout when there is no DMX signal.
- 14) If you choose **Hold** the fixture will remember the last settings and will not go out when there is no DMX signal.
- 15) In the menu option **Dmx Synchronous** you can choose between **ON** or **OFF**.
- 16) If you choose **ON**, you activate the tool which helps to keep multiple fixtures synchronized when using them in master slave mode, even after a certain amount of time.

## 6. Sound control Mode

With this menu you can set the sound sensitivity of the device.

- 01) Press the **Mode** button until the display shows **SOUND**.
- 02) Press the **Setup** button to open the menu.
- 03) Press the **Up/Down** buttons to set the sound sensitivity. The adjustment range is between **Sensitivity:00** **Up/Down** **Sensitivity:31**, from OFF to high sound sensitivity.



## 7. Manual Mode (Static color mode)

With this menu you can create a static color.

- 01) Press the **Mode** button until the display shows .
- 02) Press the **Setup** button to open the menu.
- 03) With the **Setup** button you can scroll through the colors **Red, Green, Blue** and **White**.



- 04) With the **Up/Down** buttons you can set the intensity of the colors. The adjustment range is between 000-255, from OFF to maximum intensity.

## 8. Slave Mode

With this menu you can set the device as a slave device.

- 01) Press the **Mode** button until the display shows .
- 02) If the device has not been set to slave, it is automatically classified as a master device. All slave devices will follow the master movement. If the device has been set to slave, it will react the same as its master device.

## Footswitch

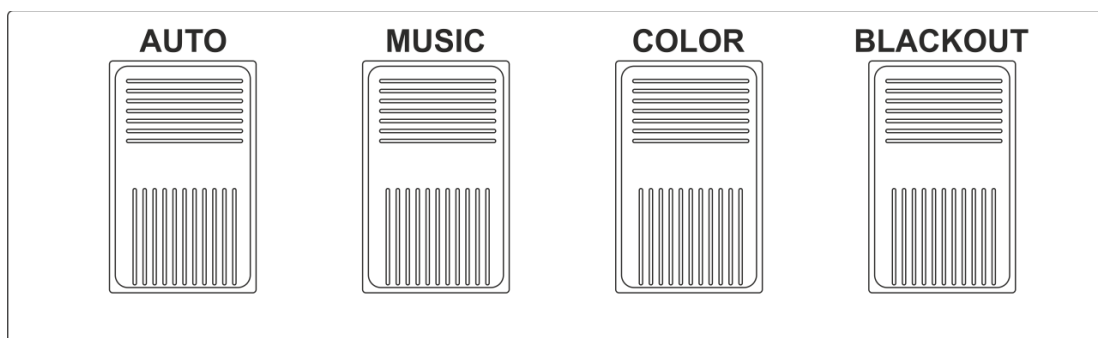

## 7. Footswitch Function (footswitch (30267) not included !)

- 01) Step on the **Auto Run** pedal to enter the auto running mode.
- 02) Step on the **Music** pedal to enter the sound active mode.
- 03) Step on the **Freeze** pedal to pause the function; Step on this pedal again to restart operation.
- 04) Step on the **Blackout** pedal to turn off all lights and then step on it again to enter the previous mode.

Foot pedal ([30267](#)) separately available

## DMX Channels

### 4 channels

#### Channel 1 – Red Dimmer intensity

0-255 Gradual adjustment Red from 0-100%

#### Channel 2 – Green Dimmer intensity

0-255 Gradual adjustment Green from 0-100%

#### Channel 3 – Blue Dimmer intensity

0-255 Gradual adjustment Blue from 0-100%

#### Channel 4 – White Dimmer intensity

0-255 Gradual adjustment White from 0-100%

### 5 channels

#### Channel 1 – Master Dimmer

0-255 Gradual adjustment, from dark to brightest 0-100%

#### Channel 2 – Linear Strobe (CH1 must be set between 001-255 )

0-10 Off

11-255 Linear strobe intensity, from low to high frequency

#### Channel 3 – Color presets (CH1 must be set between 001-255 )

0-7 No function

8-13 Color 1 (R255, G000, B000, W000)

14-20 Color 2 (R255, G000, B000, W100)

21-27 Color 3 (R255, G000, B000, W200)

28-34 Color 4 (R255, G050, B000, W000)

35-41 Color 5 (R255, G150, B000, W000)

42-48 Color 6 (R255, G255, B000, W000)

49-55 Color 7 (R255, G255, B000, W075)

56-62 Color 8 (R000, G255, B000, W255)

63-69 Color 9 (R000, G255, B000, W150)

70-76 Color 10 (R000, G255, B000, W050)

77-83 Color 11 (R000, G255, B000, W000)

84-90 Color 12 (R000, G255, B050, W000)

91-97 Color 13 (R000, G255, B150, W000)

98-104 Color 14 (R000, G255, B255, W000)

105-111 Color 15 (R000, G255, B255, W075)

112-118 Color 16 (R000, G255, B255, W150)

119-125 Color 17 (R000, G100, B255, W255)

126-132 Color 18 (R000, G000, B255, W100)

133-139 Color 19 (R000, G000, B255, W050)

140-146 Color 20 (R000, G000, B255, W000)

147-153 Color 21 (R075, G000, B255, W000)

154-160 Color 22 (R160, G000, B255, W000)

161-167 Color 23 (R255, G000, B255, W000)

168-174 Color 24 (R255, G000, B175, W000)

175-181 Color 25 (R255, G000, B100, W000)

182-188 Color 26 (R255, G000, B100, W050)

189-195 Color 27 (R255, G000, B025, W050)

196-202 Color 28 (R255, G000, B025, W025)

203-209 Color 29 (R255, G000, B025, W000)

## Compact Power Lightset 4 RGBW

210-216	Color 30 (R000, G000, B000, W255)
217-223	Color 31 (R075, G075, B000, W255)
224-230	Color 32 (R000, G000, B100, W255)
231-255	Color 33 (R255, G255, B255, W255)

### Channel 4 – Color running (CH1 must be set must between 001-255 )

0-5	No function
6-15	Program 01
16-25	Program 02
26-35	Program 03
36-45	Program 04
46-55	Program 05
56-65	Program 06
66-75	Program 07
76-85	Program 08
86-95	Program 09
96-105	Program 10
106-115	Program 11
116-125	Program 12
126-135	Program 13
136-145	Program 14
146-155	Program 15
156-165	Program 16
166-175	Program 17
176-185	Program 18
186-195	Program 19
196-205	Program 20
206-215	Program 21
216-225	Program 22
226-235	Program 23
236-255	Sound-controlled

### Channel 5 – Program Speed (CH4 must be set between 006-235 )

0-255	Gradual speed adjustment, from slow to fast
-------	---

### Channel 5 – Sound Sensitivity (CH4 must be set between 236-255 )

0-255	Gradual sound sensitivity from low sensitivity to high sensitivity
-------	--

## 6 channels

### Channel 1 – Master Dimmer

0-255 Gradual adjustment, from dark to brightest 0-100%

### Channel 2 – Linear Strobe (CH1 must be set between 001-255 ⚠)

0-10 Off

11-255 Linear strobe intensity, from low to high frequency

### Channel 3 – Red color intensity (CH1 must be set between 001-255 ⚠)

0-255 Gradual adjustment Red from 0 – 100%

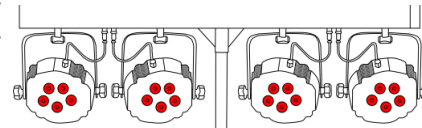

### Channel 4 – Green color intensity (CH1 must be set between 001-255 ⚠)

0-255 Gradual adjustment Green from 0 – 100%

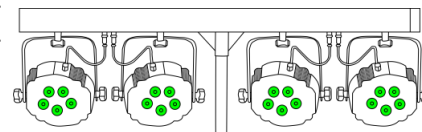

### Channel 5 – Blue color intensity (CH1 must be set between 001-255 ⚠)

0-255 Gradual adjustment Blue from 0 – 100%

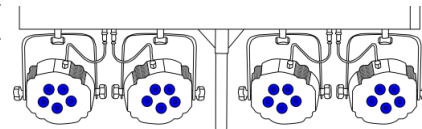

### Channel 6 – White color intensity (CH1 must be set between 001-255 ⚠)

0-255 Gradual adjustment White from 0 – 100%

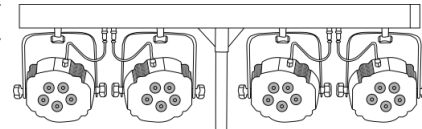

## 8 channels

### Channel 1 – Red color intensity

0-255 Gradual adjustment Red from 0 – 100%

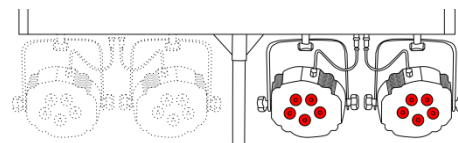

### Channel 2 – Green color intensity

0-255 Gradual adjustment Green from 0 – 100%

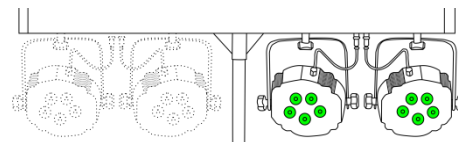

### Channel 3 – Blue color intensity

0-255 Gradual adjustment Blue from 0 – 100%

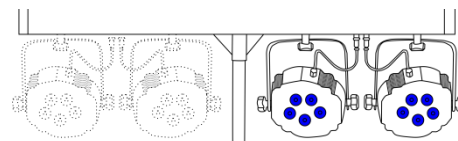

### Channel 4 – White color intensity

0-255 Gradual adjustment White from 0 – 100%

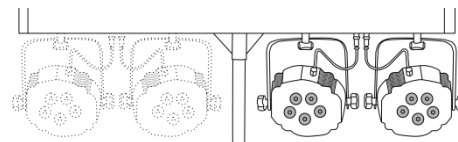

### Channel 5 – Red color intensity

0-255 Gradual adjustment Red from 0 – 100%

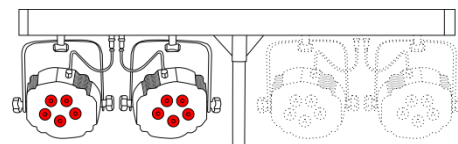

### Channel 6 – Green color intensity

0-255 Gradual adjustment Green from 0 – 100%

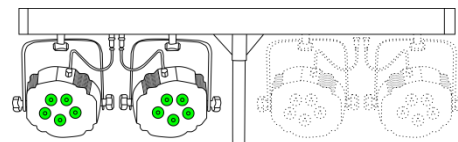

### Channel 7 – Blue color intensity

0-255 Gradual adjustment Blue from 0 – 100%

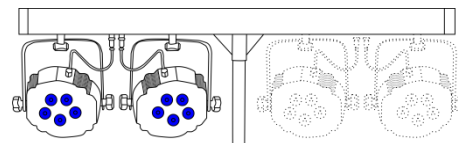

### Channel 8 – White color intensity

0-255 Gradual adjustment White from 0 – 100%

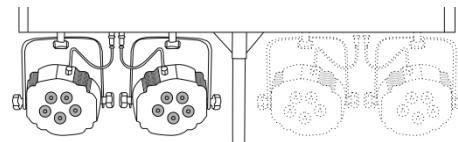

## 10 channels

### Channel 1 – Master Dimmer

0-255 Gradual adjustment, from dark to brightest 0-100%

### Channel 2 – Linear Strobe (CH1 must be set between 001-255 )

0-10 Off

11-255 Linear strobe intensity, from low to high frequency

### Channel 3 – Random Strobe (CH1 must be set between 001-255 )

0-10 Off

11-255 Random strobe intensity, from low to high frequency

### Channel 4 – Color presets (CH1 must be set between 001-255 )

0-7 No function

8-13 Color 1 (R255, G000, B000, W000)

14-20 Color 2 (R255, G000, B000, W100)

21-27 Color 3 (R255, G000, B000, W200)

28-34 Color 4 (R255, G050, B000, W000)

35-41 Color 5 (R255, G150, B000, W000)

42-48 Color 6 (R255, G255, B000, W000)

49-55 Color 7 (R255, G255, B000, W075)

56-62 Color 8 (R000, G255, B000, W255)

63-69 Color 9 (R000, G255, B000, W150)

70-76 Color 10 (R000, G255, B000, W050)

77-83 Color 11 (R000, G255, B000, W000)

84-90 Color 12 (R000, G255, B050, W000)

91-97 Color 13 (R000, G255, B150, W000)

98-104 Color 14 (R000, G255, B255, W000)

105-111 Color 15 (R000, G255, B255, W075)

112-118 Color 16 (R000, G255, B255, W150)

119-125 Color 17 (R000, G100, B255, W255)

126-132 Color 18 (R000, G000, B255, W100)

133-139 Color 19 (R000, G000, B255, W050)

140-146 Color 20 (R000, G000, B255, W000)

147-153 Color 21 (R075, G000, B255, W000)

154-160 Color 22 (R160, G000, B255, W000)

161-167 Color 23 (R255, G000, B255, W000)

168-174 Color 24 (R255, G000, B175, W000)

175-181 Color 25 (R255, G000, B100, W000)

182-188 Color 26 (R255, G000, B100, W050)

189-195 Color 27 (R255, G000, B025, W050)

196-202 Color 28 (R255, G000, B025, W025)

203-209 Color 29 (R255, G000, B025, W000)

210-216 Color 30 (R000, G000, B000, W255)

217-223 Color 31 (R075, G075, B000, W255)

224-230 Color 32 (R000, G000, B100, W255)

231-255 Color 33 (R255, G255, B255, W255)

### Channel 5 – Color running (CH1 must be set must between 001-255 )

0-5 No function

6-15 Program 01

16-25 Program 02

26-35 Program 03

36-45 Program 04

46-55	Program 05
56-65	Program 06
66-75	Program 07
76-85	Program 08
86-95	Program 09
96-105	Program 10
106-115	Program 11
116-125	Program 12
126-135	Program 13
136-145	Program 14
146-155	Program 15
156-165	Program 16
166-175	Program 17
176-185	Program 18
186-195	Program 19
196-205	Program 20
206-215	Program 21
216-225	Program 22
226-235	Program 23
236-255	Sound-controlled

**Channel 6 – Program Speed (CH5 must be set between 006-235 ⚠ )**

0-255 Gradual speed adjustment, from slow to fast

**Channel 6 – Sound Sensitivity (CH5 must be set between 236-255 ⚠ )**

0-255 Gradual sound sensitivity from low sensitivity to high sensitivity

**Channel 7 – Red color intensity (CH1 must be set between 001-255 ⚠ )**

0-255 Gradual adjustment Red from 0 – 100%

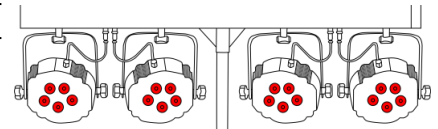

**Channel 8 – Green color intensity (CH1 must be set between 001-255 ⚠ )**

0-255 Gradual adjustment Green from 0 – 100%

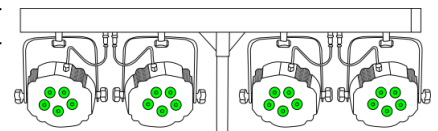

**Channel 9 – Blue color intensity (CH1 must be set between 001-255 ⚠ )**

0-255 Gradual adjustment Blue from 0 – 100%

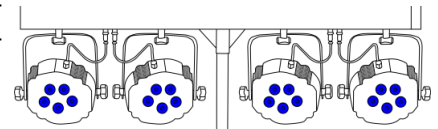

**Channel 10 – White color intensity (CH1 must be set between 001-255 ⚠ )**

0-255 Gradual adjustment White from 0 – 100%

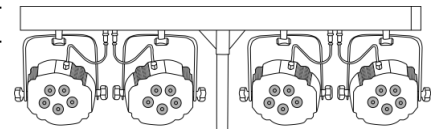

## 16 channels

### Channel 1 – Red color intensity

0-255 Gradual adjustment Red from 0 – 100%

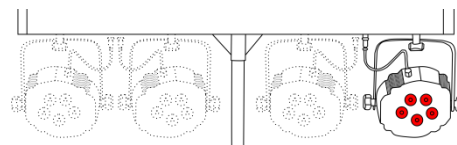

### Channel 2 – Green color intensity

0-255 Gradual adjustment Green from 0 – 100%

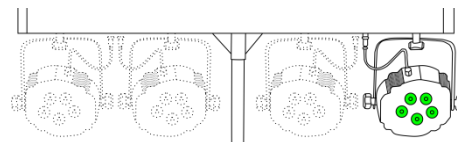

### Channel 3 – Blue color intensity

0-255 Gradual adjustment Blue from 0 – 100%

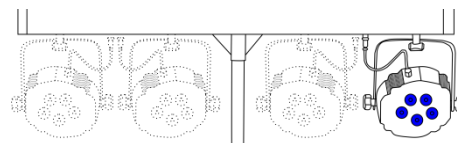

### Channel 4 – White color intensity

0-255 Gradual adjustment White from 0 – 100%

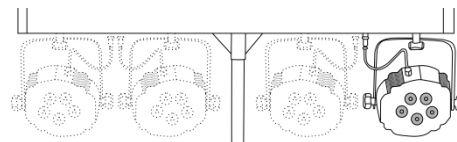

### Channel 5 – Red color intensity

0-255 Gradual adjustment Red from 0 – 100%

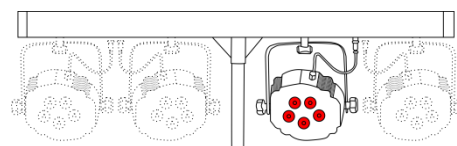

### Channel 6 – Green color intensity

0-255 Gradual adjustment Green from 0 – 100%

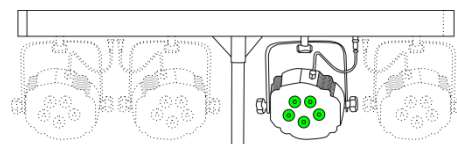

### Channel 7 – Blue color intensity

0-255 Gradual adjustment Blue from 0 – 100%

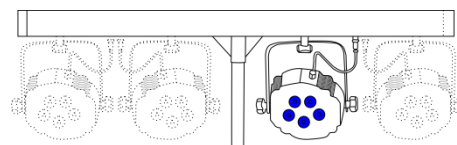

### Channel 8 – White color intensity

0-255 Gradual adjustment White from 0 – 100%

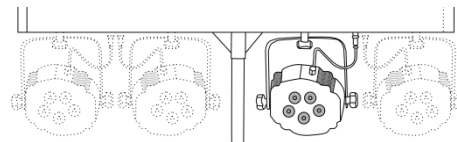

### Channel 9 – Red color intensity

0-255 Gradual adjustment Red from 0 – 100%

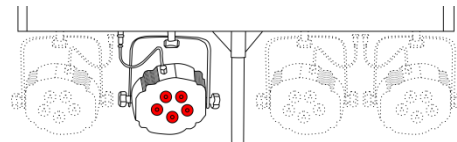



## Channel 10 – Green color intensity

0-255 Gradual adjustment Green from 0 – 100%

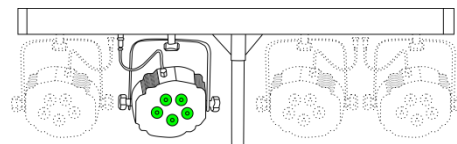

## Channel 11 – Blue color intensity

0-255 Gradual adjustment Blue from 0 – 100%

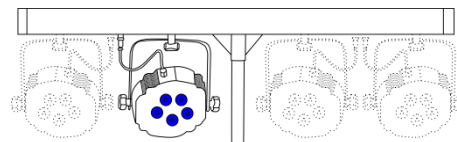

## Channel 12 – White color intensity

0-255 Gradual adjustment White from 0 – 100%

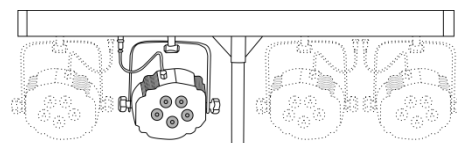

## Channel 13 – Red color intensity

0-255 Gradual adjustment Red from 0 – 100%

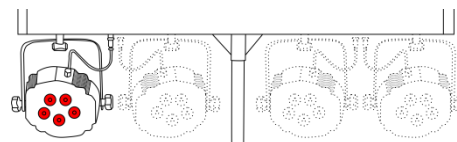

## Channel 14 – Green color intensity

0-255 Gradual adjustment Green from 0 – 100%

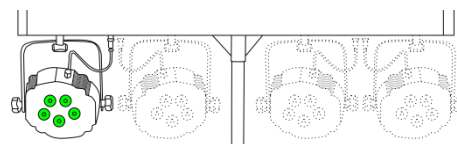

## Channel 15 – Blue color intensity

0-255 Gradual adjustment Blue from 0 – 100%

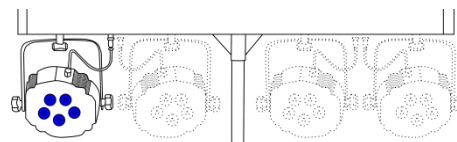

## Channel 16 – White color intensity

0-255 Gradual adjustment White from 0 – 100%

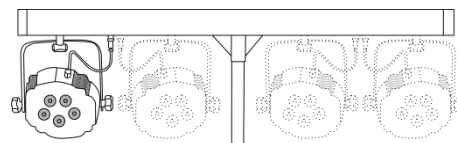

19 channels

## Channel 1 – Master Dimmer

0-255 Gradual adjustment, from dark to brightest 0-100%

## Channel 2 – Linear Strobe (CH1 must be set between 001-255 ⚠ )

0-10 Off

11-255 Linear strobe intensity, from low to high frequency

## Channel 3 – Random Strobe (CH1 must be set between 001-255 ⚠ )

0-10 Off

11-255 Random strobe intensity, from low to high frequency

## Channel 4 – Red color intensity

0-255 Gradual adjustment Red from 0 – 100%

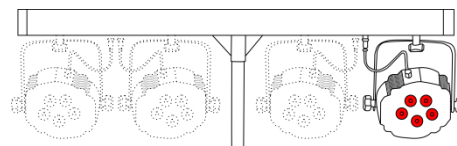

## Channel 5 – Green color intensity

0-255 Gradual adjustment Green from 0 – 100%

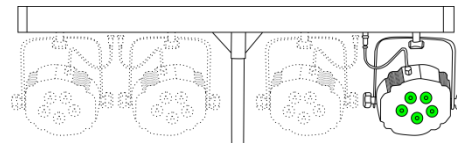

## Channel 6 – Blue color intensity

0-255 Gradual adjustment Blue from 0 – 100%

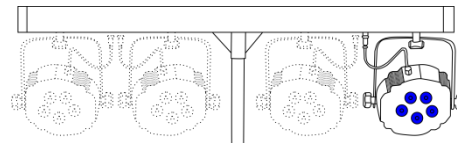

## Channel 7 – White color intensity

0-255 Gradual adjustment White from 0 – 100%

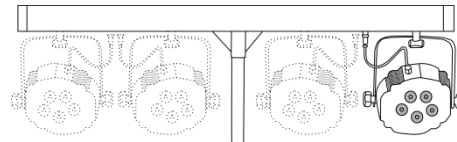

## Channel 8 – Red color intensity

0-255 Gradual adjustment Red from 0 – 100%

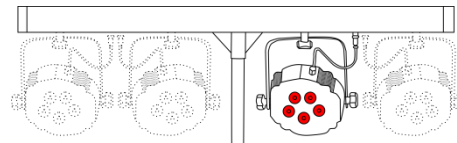

## Channel 9 – Green color intensity

0-255 Gradual adjustment Green from 0 – 100%

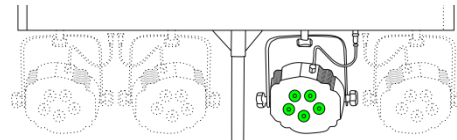

## Channel 10 – Blue color intensity

0-255 Gradual adjustment Blue from 0 – 100%

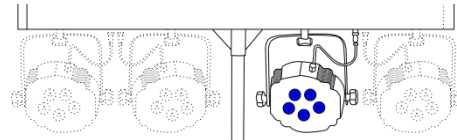

## Channel 11 – White color intensity

0-255 Gradual adjustment White from 0 – 100%

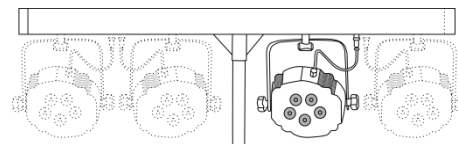

## Channel 12 – Red color intensity

0-255 Gradual adjustment Red from 0 – 100%

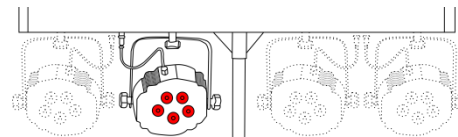

## Channel 13 – Green color intensity

0-255 Gradual adjustment Green from 0 – 100%

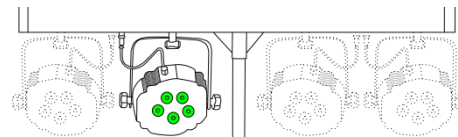

## Channel 14 – Blue color intensity

0-255 Gradual adjustment Blue from 0 – 100%

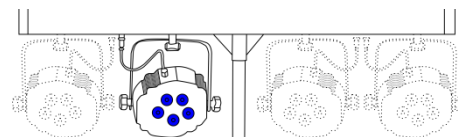

## Channel 15 – White color intensity

0-255 Gradual adjustment White from 0 – 100%

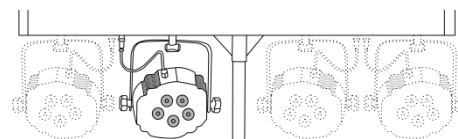

## Channel 16 – Red color intensity

0-255 Gradual adjustment Red from 0 – 100%

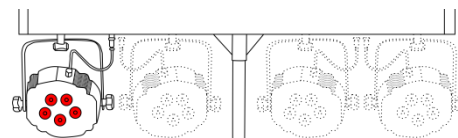

## Channel 17 – Green color intensity

0-255 Gradual adjustment Green from 0 – 100%

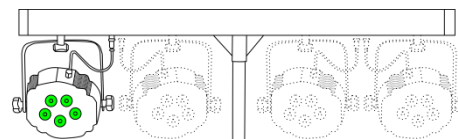

## Channel 18 – Blue color intensity

0-255 Gradual adjustment Blue from 0 – 100%

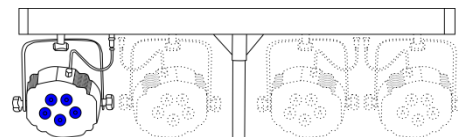

## Channel 19 – White color intensity

0-255 Gradual adjustment White from 0 – 100%

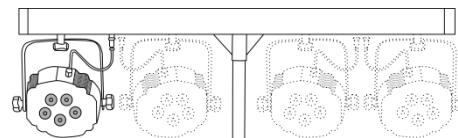

### Maintenance

---

The operator has to make sure that safety-relating and machine-technical installations are to be inspected by an expert after every year in the course of an acceptance test.

The operator has to make sure that safety-relating and machine-technical installations are to be inspected by a skilled person once a year.

The following points have to be considered during the inspection:

- 01) All screws used for installing the device or parts of the device have to be tightly connected and must not be corroded.
- 02) There may not be any deformations on housings, fixations and installation spots.
- 03) Mechanically moving parts like axles, eyes and others may not show any traces of wearing.
- 04) The electric power supply cables must not show any damages or material fatigue.

The Showtec Compact Power Lightset 4 RGBW requires almost no maintenance. However, you should keep the unit clean. Otherwise, the fixture's light-output will be significantly reduced. Disconnect the mains power supply and then wipe the cover with a damp cloth. Wipe the front glass panel clean with glass cleaner and a soft cloth. Do not use alcohol or solvents. The front glass panel will require weekly cleaning, as smoke-fluid tends to build up residues, reducing the light-output very quickly. Do not immerse in liquid.

Keep connections clean. Disconnect electric power, and then wipe the DMX and audio connections with a damp cloth. Make sure connections are thoroughly dry before linking equipment or supplying electric power.

### Replacing a Fuse

Power surges, short-circuit or inappropriate electrical power supply may cause a fuse to burn out. If the fuse burns out, the product will not function whatsoever. If this happens, follow the directions below:

- 01) Unplug the unit from electric power source.
- 02) Insert a flat-head screwdriver into a slot in the fuse cover. Gently pry up the fuse cover. the fuse will come out.
- 03) Remove the used fuse. If brown or unclear, it is burned out.
- 04) Insert the replacement fuse into the holder where the old fuse was. Reinsert the fuse cover. Be sure to use a fuse of the same type and specification. See the product specification label for details.

### Troubleshooting

---

#### No Light

This troubleshooting guide is meant to help solve simple problems.

If a problem occurs, follow the steps below in sequence until a solution is found. Once the unit operates properly, do not carry out the following steps.

If the light effect does not operate properly, refer servicing to a technician.

Response: Suspect four potential problem areas as the power supply, the LEDs, the fuse.

- 01) Power supply. Check that the unit is plugged into an appropriate power supply.
- 02) The LEDs. Return the Compact Power Lightset 4 RGBW to your Showtec dealer.
- 03) The fuse. Replace the fuse. See page 27 for replacing the fuse.
- 04) If all of the above appears to be in order, switch the unit on again.
- 05) If you are unable to determine the cause of the problem, do not open the Compact Power Lightset 4 RGBW, as this may damage the unit and the warranty will become void.
- 06) Return the device to your Showtec dealer.

## No Response to DMX

Response: Suspect the DMX cable or connectors, a controller malfunction, a light effect DMX card malfunction.

01) Check the DMX setting. Make sure that DMX addresses are correct.

02) Check the DMX cable: Unplug the unit; change the DMX cable; then reconnect to electrical power. Try your DMX control again.

03) Determine whether the controller or light effect is to blame. Does the controller operate properly with other DMX products? If not, take the controller in for repair. If it does, take the DMX cable and the light effect to a qualified technician.

Problem	Probable cause(s)	Solution
One or more fixtures do not function at all	No power to the fixture	<ul style="list-style-type: none"> <li>Check if power is switched on and cables are plugged in.</li> </ul>
Fixtures reset correctly, but all respond erratically or not at all to the controller	Primary fuse blown	<ul style="list-style-type: none"> <li>Replace fuse</li> </ul>
	The controller is not connected. 3-pin XLR Out of the controller does not match XLR Out of the first fixture on the link (i.e. signal is reversed)	<ul style="list-style-type: none"> <li>Connect controller.</li> <li>Install a phase reversing cable between the controller and the first fixture on the link</li> </ul>
Fixtures reset correctly, but some respond erratically or not at all to the controller	Poor data quality	<ul style="list-style-type: none"> <li>Check data quality. If much lower than 100 percent, the problem may be a bad data link connection, poor quality or broken cables, missing termination plug, or a defective fixture disturbing the link</li> </ul>
	Bad data link connection	<ul style="list-style-type: none"> <li>Inspect connections and cables. Correct poor connections. Repair or replace damaged cables</li> </ul>
	Data link not terminated with 120 Ohm termination plug	<ul style="list-style-type: none"> <li>Insert termination plug in output jack of the last fixture on the link</li> </ul>
	Incorrect addressing of the fixtures	<ul style="list-style-type: none"> <li>Check address setting</li> </ul>
	One of the fixtures is defective and disturbs data transmission on the link	<ul style="list-style-type: none"> <li>Bypass one fixture at a time until normal operation is restored: unplug both connectors and connect them directly together.</li> <li>Have the defective fixture serviced by a qualified technician</li> </ul>
	3-pin XLR Out on the fixtures does not match (pins 2 and 3 reversed)	<ul style="list-style-type: none"> <li>Install a phase-reversing cable between the fixtures or swap pin 2 and 3 in the fixture that behaves erratically</li> </ul>
No light or lamp cuts out intermittently	Fixture is too hot	<ul style="list-style-type: none"> <li>Allow the fixture to cool down</li> <li>Clean the fan</li> <li>Turn up the air conditioning</li> </ul>
	LEDs damaged	<ul style="list-style-type: none"> <li>Disconnect the fixture and return it to your dealer</li> </ul>
	The power supply settings do not match local AC voltage and frequency	<ul style="list-style-type: none"> <li>Disconnect fixture. Check settings and correct if necessary</li> </ul>

## Product Specifications

Model:	Showtec Compact Power Lightset 4 RGBW
Input Voltage:	100-240V AC, 50/60Hz
Drive current:	330mA
Refresh rate:	7,8 KHz
Consumption Power	90 Watt
DMX linking:	30pcs
Fuse:	5S1.5A / 250V
Dimensions T-bar + 4 parcans:	845 x 55 x 70 mm (LXWXH)
Weight T-bar + 4 parcans:	7,3 kg
<b>Operating and Programming:</b>	
Signal pin OUT:	Pin 1 (earth), pin 2 (-), pin 3 (+)
DMX Mode:	4, 8, 16, 18 and 20 DMX channel operation
Signal input:	3-pin XLR male
Signal output:	3-pin XLR female
<b>Electro-mechanical effects:</b>	
Light source:	5x 4-in-1 RGBW LEDs 4W (per spot)
Beam Angle:	25°
Dimmer:	0-100%
Strobe:	0-20Hz
Color Range:	RGBW
Cooling:	Aluminum heat sink
Display:	LCD display
Housing:	Black Aluminum and Iron
IP rating:	IP-20
DMX-control:	DMX512 via standard DMX-controller
Control:	DMX512, Sound, Stand-alone, Master/slave, Optional footswitch
Connections:	XLR Data in/out (XLR 3-pin), IEC Power In and Out (10a)
Built-in microphone	
Max. ambient temperature $t_a$ :	40°C
Max. housing temperature $t_B$ :	80°C
<b>Minimum distance:</b>	
Minimum distance from flammable surfaces:	0,5 m
Minimum distance to lighted object:	1 m



Website: [www.Showtec.info](http://www.Showtec.info)  
 Email: [service@highlite.nl](mailto:service@highlite.nl)

## Dimensions

### T-bar + 4 parcans

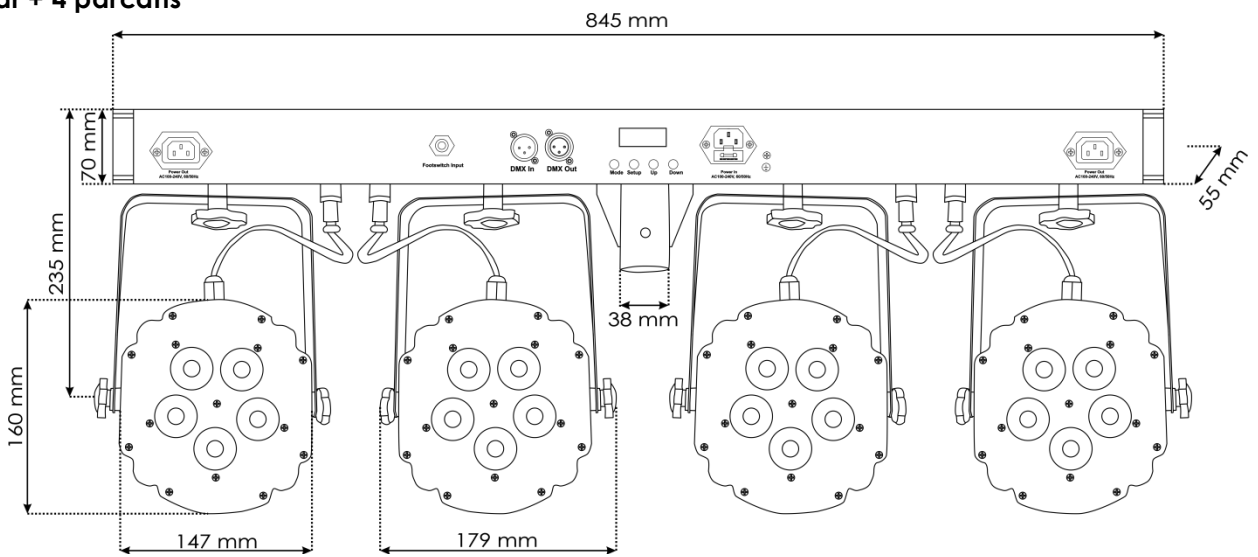

### Stand

Weight stand: 3,7 kg

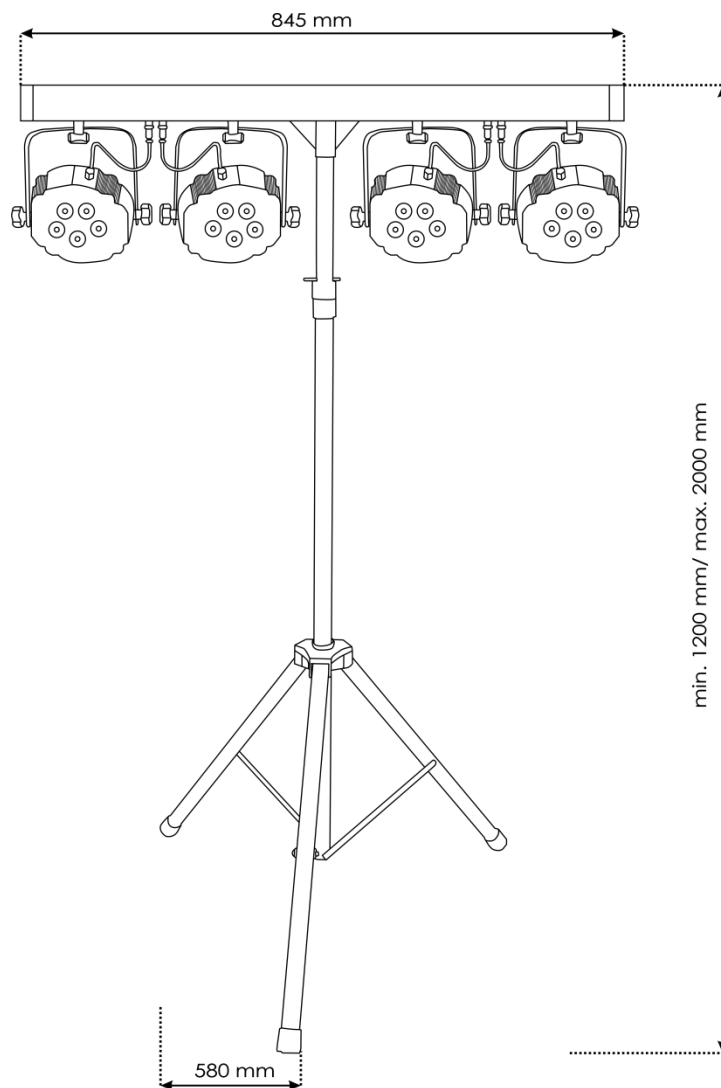



©2016 Showtec