



# VIZI BEAM RXONE



## User Manual

©2021 ADJ Products, LLC all rights reserved. Information, specifications, diagrams, images, and instructions herein are subject to change without notice. ADJ Products, LLC logo and identifying product names and numbers herein are trademarks of ADJ Products, LLC. Copyright protection claimed includes all forms and matters of copyrightable materials and information now allowed by statutory or judicial law or hereinafter granted. Product names used in this document may be trademarks or registered trademarks of their respective companies and are hereby acknowledged. All non-ADJ Products, LLC brands and product names are trademarks or registered trademarks of their respective companies.

**ADJ Products, LLC** and all affiliated companies hereby disclaim any and all liabilities for property, equipment, building, and electrical damages, injuries to any persons, and direct or indirect economic loss associated with the use or reliance of any information contained within this document, and/or as a result of the improper, unsafe, insufficient and negligent assembly, installation, rigging, and operation of this product.

## DOCUMENT VERSION

Due to additional product features and/or enhancements, an updated version of this document may be available online. Please check [www.adj.com](http://www.adj.com) for the latest revision/update of this manual before beginning installation and/or programming.

Date	Document Version	Software Version $\geq$	DMX Channel Mode	Notes
07/24/17	1	1.0	15/17	Initial Release
11/06/19	2	4.3	15/17	Updated Lamp Warnings Added
01/08/21	3	4.4	15/17	Primary/Secondary Update, Updated Specifications
12/2/21	4	N/C	15/17	Safety Precautions Information Updated

### Europe Energy Saving Notice

Energy Saving Matters (EuP 2009/125/EC)

Saving electric energy is key to protecting the environment. Please turn off all electrical products when they are not in use. To avoid power consumption in idle mode, disconnect all electrical equipment from power when not in use. Thank you!

General Information	4
Safety Precautions	5
Features	6
General Instructions   Handling Precautions   Product Registration	7
Important Discharge Lamp Warnings	8
Mounting	10
Dimensional Drawing   Photometric Chart	12
Base Layout	13
DMX Set Up	14
Power Cord Daisy Chain   DMX Control	16
15 Channel Mode	17
17 Channel Mode	22
System Menu	27
Offset Menu	31
Operation   Primary-Secondary Set Up	32
ADJ UC IR/Airstream IR Control	33
Lamp & Fuse Replacement	34
Lamp Replacement	35
Cleaning   Trouble Shooting	37
Warranty	38
Specifications	39

**Unpacking:** Thank you for purchasing the Vizi Beam RXONE by ADJ Products, LLC®. Every Vizi Beam RXONE has been thoroughly tested and has been shipped in perfect operating condition. Carefully check the shipping carton for damage that may have occurred during shipping. If the carton appears to be damaged, carefully inspect your fixture for any damage and be sure all equipment necessary to operate the unit has arrived intact. In the event that damage has been found or parts are missing, please contact our toll free customer support number for further instructions. Please do not return this unit to your dealer without contacting customer support first.

**Introduction:** The Vizi Beam RXONE is a DMX intelligent, moving head fixture. This fixture has 3 operating modes; sound active mode, show mode, and DMX control. This unit can be used as a stand alone unit or in a Primary-Secondary configuration. For best results use fog or special effects smoke to enhance the beams projections.

**During the initial start-up or use of this product, a light smoke or smell may arise from the unit. This is a normal process and is caused by the heat associated with the lamp.**

**Customer Support:** ADJ Products, LLC® provides a toll free customer support line, to provide help and to answer any questions that may arise during your set up or initial operation. You may also visit us on the web at [www.adj.com](http://www.adj.com) for any comments or suggestions. Service Hours are Monday through Friday 8:00 a.m. to 4:30 p.m. Pacific Standard Time.

Voice: (800) 322-6337  
Fax: (323) 582-2941  
E-mail: [support@adj.com](mailto:support@adj.com)

To purchase parts online, please visit [parts.adj.com](http://parts.adj.com).

**Warning!** To prevent or reduce the risk of electrical shock or fire, do not expose this unit to rain or moisture.

**Warning! This unit can cause severe eye damage! Never look directly into the light source at any time!**

**WARNING: FIRE HAZARD! DUE TO THE EXTREME HEAT EMITTED FROM THIS FIXTURE, THE MINIMUM DISTANCE TO LIGHTED OBJECTS IS 8 METERS (26 FT).**

***For Your Own Personal Safety, Please Read and Understand This Manual Completely Before You Attempt To Install Or Operate This Unit!***

- To reduce the risk of electrical shock or fire, do not expose this unit rain or moisture.
- Do not spill water or other liquids into or on to your unit.
- Be sure that the local power outlet matches the required voltage for your unit.
- Do not attempt to operate this unit if the power cord is frayed or broken.
- Do not attempt to remove or break off the ground prong from the electrical cord. This prong is used to reduce the risk of electrical shock and fire in case of an internal short.
- Disconnect from main power before making any type of connection.
- Do not remove the cover under any conditions. There are no user serviceable parts inside.
- Never operate this unit with the cover removed.
- Always be sure to mount this unit in an area that will allow proper ventilation. Allow about 7.9" (20cm) between this device and a wall.
- Do not attempt to operate this unit if it has been damaged in any way.
- This unit is intended for indoor use only, use of this product outdoors voids all warranties.
- Always mount this unit in safe and stable matter.
- Power-supply cords should be routed so that they are not likely to be walked on or pinched by items placed upon or against them, paying particular attention to cords at plugs, convenience receptacles, and the point where they exit from the appliance.
- Cleaning - The fixture should be cleaned only as recommended by the manufacturer. See the **Cleaning** section of this manual for details.
- Heat - This fixture should be situated away from heat sources such as radiators, heat registers, stoves, or other appliances (including amplifiers) that produce heat.
- The fixture should be serviced by qualified service personnel when:
  - A. Objects have fallen, or liquid has been spilled into, the appliance.
  - B. The appliance has been exposed to rain or water.
  - C. The appliance does not appear to operate normally or exhibits a marked change in performance.

- Osram® Sirius HRI 100W 1R Discharge Lamp
- Micro-Stepping Motors for Smooth Color and Gobo Transitions
- DMX-512 Protocol Compatible (2 DMX Modes: 15 Channels & 17 Channels)
- 3-Pin XLR In/Out
- Independent Gobo and Color Wheels
- 15 Static Fixed Gobos + Spot
- 14 Colors, Plus White and Split Colors
- 16 Facet Prism with Rotation
- Frost Filter
- Strobe Effect
- 3 Degree Beam Angle
- 540° Pan Movement
- 270° Tilt Movement
- Pan/Tilt Invert
- Pan/Tilt Speed Adjustment
- Digital Display for Address and Function Setting
- Power Cord Daisy Chain (See **Power Cord Daisy Chain** section of this manual for details)

To optimize the performance of this product, please read these operating instructions carefully to familiarize yourself with the basic operations of this unit. These instructions contain important safety information regarding the use and maintenance of this unit. Please keep this manual with the unit for future reference.

**Caution!** There are no user serviceable parts inside this unit. Do not attempt any repairs yourself, doing so will void your manufacturer's warranty. In the unlikely event your unit may require service, please contact ADJ®.

*During operation the housing may become extremely hot. Avoid touching the unit with bare hands while in use.*

*ADJ® will not accept any liability for any resulting damages caused by the non-observance of this manual or any unauthorized modification to this unit.*

The Vizi Beam RXONE carries a one year limited warranty. Please fill out the enclosed warranty card to validate your purchase. All returned service items whether under warranty or not, must be freight pre-paid and accompany a return authorization (R.A.) number. The R.A. number must be clearly written on the outside of the return package. A brief description of the problem as well as the R.A. number must also be written down on a piece of paper and included in the shipping carton. If the unit is under warranty, you must provide a copy of your proof of purchase invoice. You may obtain an R.A. number by contacting our customer support team on our toll free customer support number. All packages returned to the service department not displaying an R.A. number on the outside of the package will be returned to the shipper at the shipper's cost.

This fixture is fitted with a discharge lamp which is highly susceptible to damage if improperly handled. **NEVER** touch the lamp located within the reflector with your bare fingers, as the oil from your hands will shorten lamp life. Also, never move the fixture until the lamps have had ample time to cool. Remember, **lamps are not covered under warranty conditions.**

This unit emits intense UV radiation which is harmful to the eyes and skin. The intense luminance of the lamp can cause severe damage to the retina. Never operate this unit without the covers in place, as these covers have been specially designed to shield against UV radiation.

***Epileptic Warning:*** *Those suffering from epilepsy should avoid looking directly into the lamp at all times.*

Avoid switching the fixture on and off repeatedly in short intervals as this will reduce lamp life and intensity.

To achieve the intensity associated with discharge lamps, these lamps use gas sealed in a high pressure environment to emit a brilliant output. Due to the high pressure involved with the construction of the lamp, the lamp may explode during prolonged extensive use. This risk is increased with age, and added care is therefore encouraged when dealing with older lamps. Extreme caution should be used when operating this or any fixture fitted with a gas discharge lamp. Never open this unit while in use.

**LAMP REPLACEMENT WARNING (Software Version <V1.0):**

This is for your safety and the life length of the unit. The Osram® 1R Discharge lamp has lifetime of 6000 hours.

ADJ recommends periodically checking the lamp running time (see the “Lamp Time” sub-section of the **System Menu** section of this manual). When the lamp approaches or reaches the 6000 hour mark, it is strongly recommended to switch the lamp out and replace it with a fresh unit.

Replace the lamp following the instructions shown in the **Lamp & Fuse Replacement** section of this manual. After replacing the lamp you must clear the LAMP TIME (see the “Lamp Time” sub-section of the **System Menu** section of this manual).

***Warning: DO NOT use this lamp for more than 6000 hours. Using the lamp any longer than the set life could seriously damage your unit.***

**WARNING! CAUTION! FIRE HAZARD! DUE TO THE EXTREME HEAT CAUSED BY THIS LAMP, THE MINIMUM DISTANCE TO LIGHTED OBJECTS IS 8 METERS (26FT).**



**LAMP REPLACEMENT WARNING (Software Version >V4.3)**

When the lamp reaches 5700 Hours of usage, the display will flash the message “**Replace Lamp-Soon**”. This message will flash for up to 10 minutes. To confirm this warning and return to normal operation, press the ENTER button.

When the lamp reaches 6000 Hours of usage, the display will flash the message “**Replace Lamp Now**”. This message will flash for up to 10 minutes. To confirm this warning and return to normal operation, press the ENTER button. **NOTE: When the fixture is powered OFF and then back ON again, the fixture display will flash the following message: “Replace Lamp Now”.**

When the lamp reaches 6200 Hours of usage, the display again will flash the message “**Replace Lamp Now**”. The unit will now no longer respond to DMX commands and enter hibernation mode, which will discontinue all fixture functionality with the exception of a few menu commands. The fixture will continue to enter into hibernation mode until the lamp is replaced and the lamp time has been reset.

See the “Lamp Time” sub-section of the **System Menu** section of this manual for the procedure on how to reset the lamp time.

**NOTE: After replacing the lamp, the lamp time MUST be reset. The lamp time must be reset to gain access to the full system menu.**

When installing the unit, the trussing or area of installation must be able to hold 10 times the weight of the unit without any deformation. The unit must be secured with a secondary safety attachment, such as an appropriately-rated safety cable. Never stand directly below the unit when mounting, removing, or servicing the unit.

Overhead mounting requires extensive experience, including calculating working load limits, installation material being used, and periodic safety inspection of all installation material and unit. If you lack these qualifications, do not attempt the installation yourself.

The installation should be checked by a skilled person once a year.

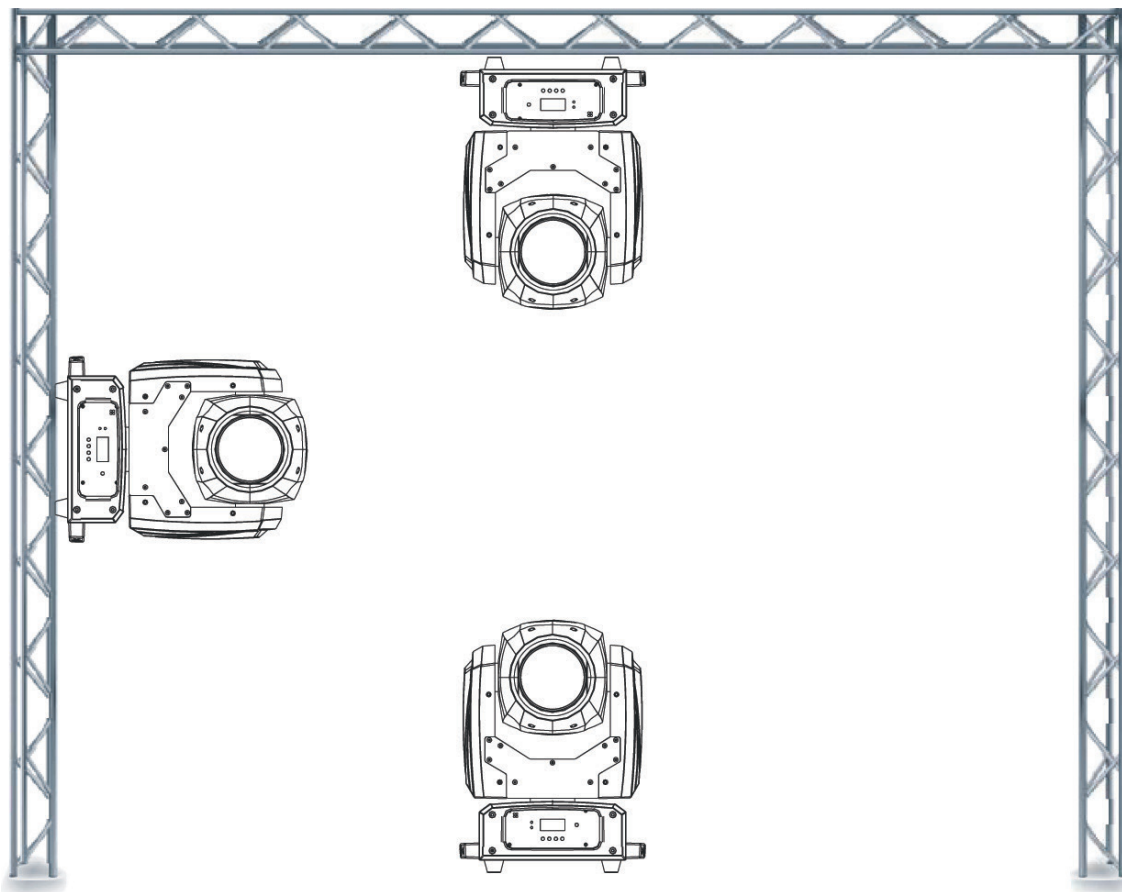

The Vizi Beam RXONE is fully operational in three different mounting positions: hanging upside-down from a ceiling, sideways on trussing, or set on a flat level surface. Be sure this fixture is kept at least 8m (26ft) away from any flammable materials (decoration etc.). Always use and install an appropriately-rated safety cable in order to prevent accidental damage and/or injury in the event the clamp fails. Never use the carrying handles for secondary attachment.

**NOTICE:** The suitable environmental temperature for this lighting fixture is between -10° C to 40° C. Do not place this lighting fixture in an environment where the temperatures are outside of this stated range. This will allow the fixture to run at its best and help prolong the fixture life.

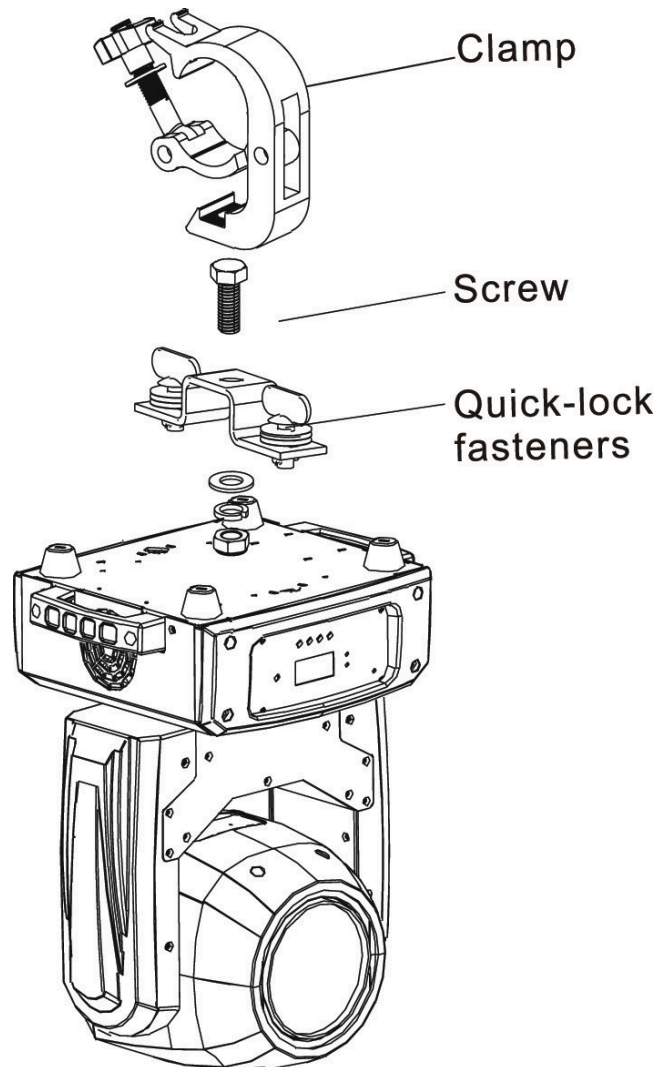

Screw one clamp onto the Omega holders using an M12 screw and nut. Insert the quick-lock fasteners of the first Omega holder into the respective holes on the bottom of the Vizi Beam RXONE. Tighten the quick-lock fasteners fully clockwise. Pull the safety-cable through the openings located on the base plate and over the trussing system or a safe fixation spot. Insert the end in the carabine and tighten the safety screw.

# Vizi Beam RXONE

# Dimensional Drawing

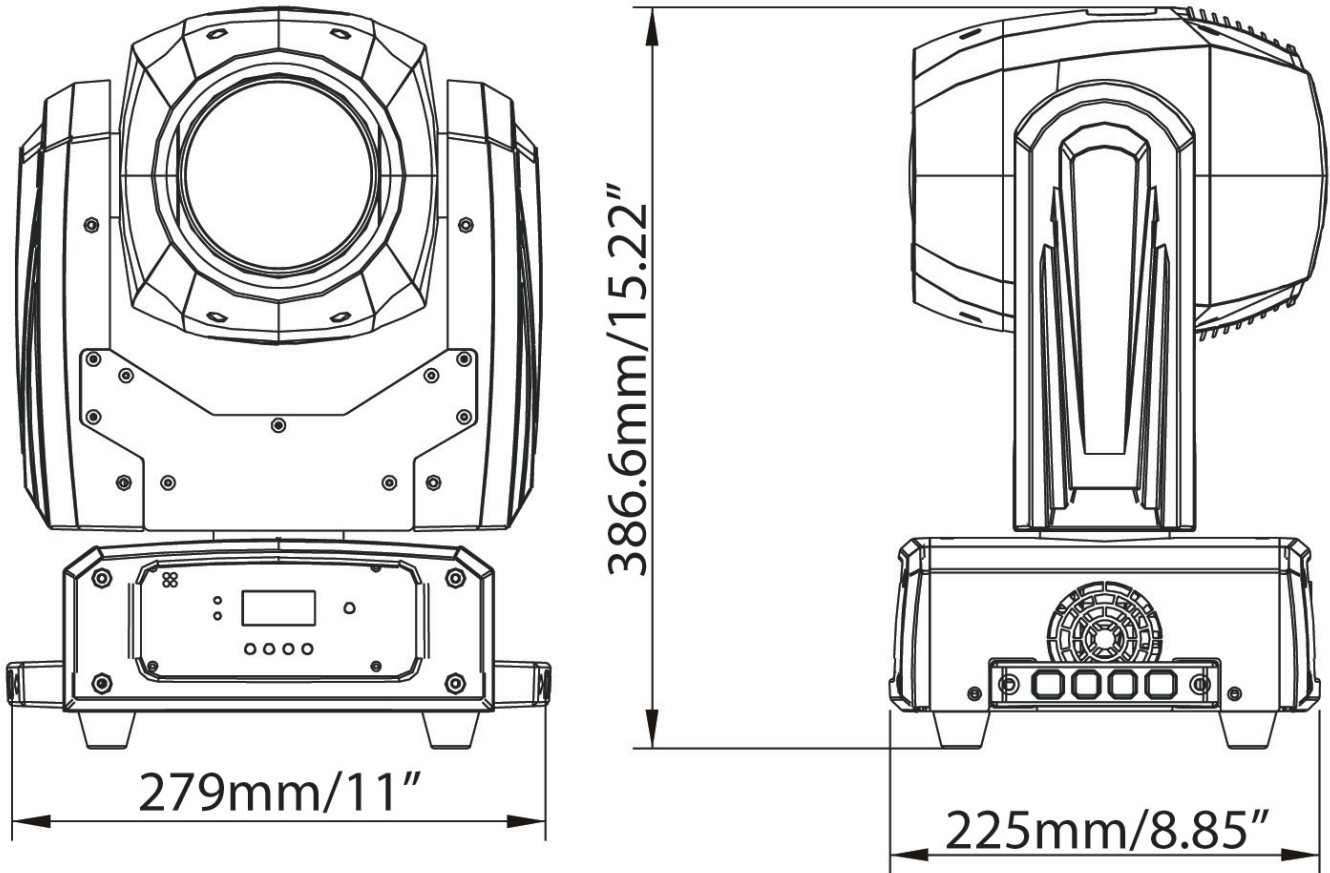

# Vizi Beam RXONE

# Photometric Chart

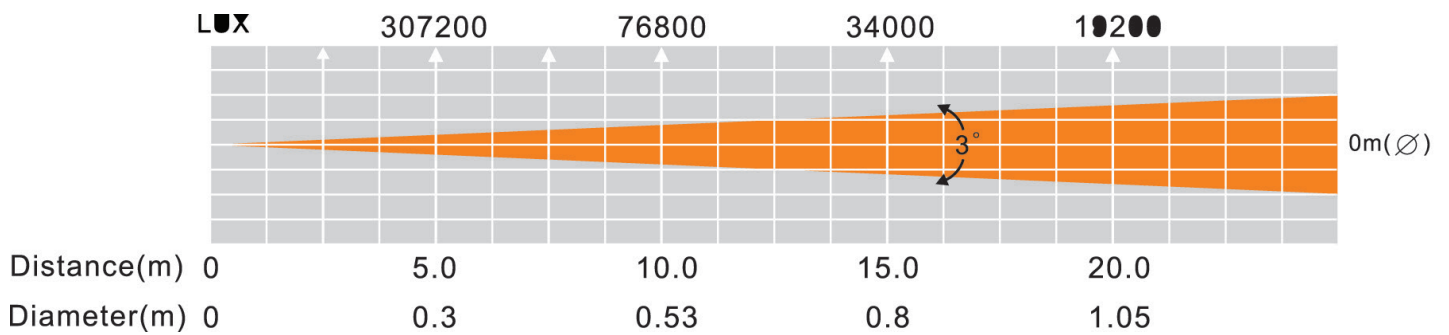

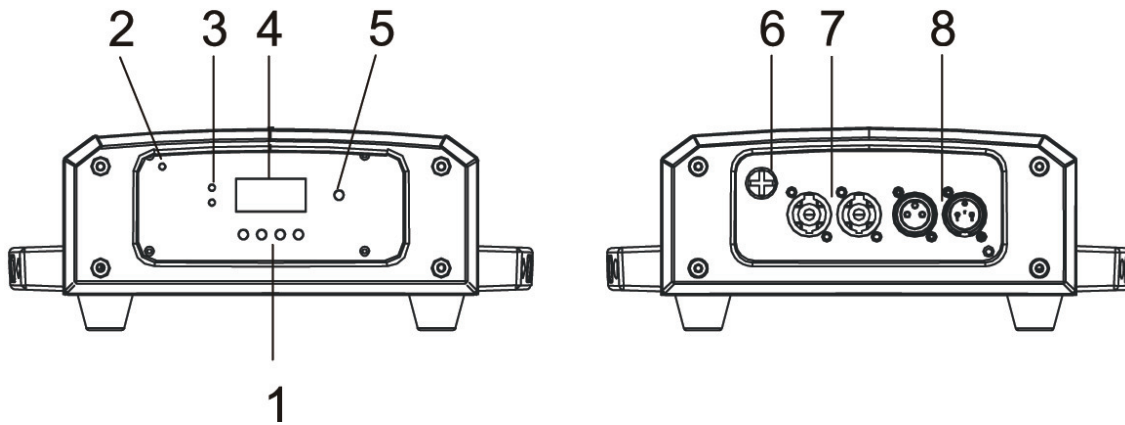

1. Button functions:

MENU	Select programming functions.	
DOWN	Go forward in the selected functions.	
UP	Go backward in the selected functions.	
ENTER	Confirm the selected functions.	

2. Microphone: Receives ambient sound of use in Sound Active Mode.

3. LED:

POWER	On	Power On
DMX	On	DMX input present

4. Function Display: Shows the various menus and selected functions.

5. IR Receiver: Receives signal from IR remote.

6. Fuse: Protects the unit from over-voltage or short circuit.

7. Power In/Out: Used to connect the unit to supply power.

8. DMX In/Out: 3-pin XLR connectors for DMX-512 operation.

**Power Supply:** The ADJ® Vizi Beam RXONE contains an electronic ballast, which will auto sense the voltage when it is plugged into the power source. With the electronic ballast you do not need to worry about wall voltage. This unit can be plugged in anywhere.

**DMX-512:** DMX is short for Digital Multiplex. This is a universal protocol used by most lighting and controller manufactures as a form of communication between intelligent fixtures and controllers. A DMX controller sends DMX data instructions from the controller to the fixture. DMX data is sent as serial data that travels from fixture to fixture via the DATA “IN” and DATA “OUT” XLR terminals located on all DMX fixtures (most controllers only have a DATA “OUT” terminal).

**DMX Linking:** DMX is a language allowing all makes and models of different manufactures to be linked together and operate from a single controller, as long as all fixtures and the controller are DMX compliant. *To ensure proper DMX data transmission, when using several DMX fixtures, try to use the shortest cable path possible. The order in which fixtures are connected in a DMX line does not influence the DMX addressing. For example; a fixture assigned a DMX address of 1 may be placed anywhere in a DMX line: at the beginning, at the end, or anywhere in the middle. When a fixture is assigned a DMX address of 1, the DMX controller knows to send DATA assigned to address 1 to that unit, no matter where it is located in the DMX chain.*

**Data Cable (DMX Cable) Requirements (For DMX and Primary/Secondary Operation):** The Vizi Beam RXONE can be controlled via DMX-512 protocol. The Vizi Beam RXONE has 2 DMX channel modes: 15 channels and 17 channels. The DMX address is set electronically using the controls on the front panel of the unit. Your unit and your DMX controller require an approved DMX-512 110 Ohm Data cable for data input and data output (Figure 1). We recommend Accu-Cable DMX cables. If you are making your own cables, be sure to use standard 110-120 Ohm shielded cable (This cable may be purchased at almost all professional sound and lighting stores). Your cables should be made with a male and female XLR connector on either end of the cable. Also remember that DMX cable must be daisy chained and cannot be split.



Figure 1



**Notice:** Be sure to follow figures two and three when making your own cables. Do not use the ground lug on the XLR connector. Do not connect the cable’s shield conductor to the ground lug or allow the shield conductor to come in contact with the XLR’s outer casing. Grounding the shield could cause a short circuit and result in erratic behavior.

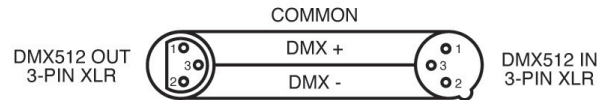

Figure 2

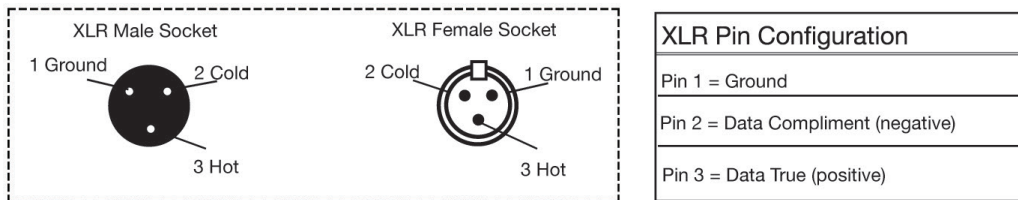
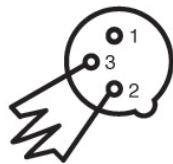

Figure 3

**Special Note: Line Termination.** When longer runs of cable are used, you may need to use a terminator on the last unit to avoid erratic behavior. A terminator is a 110-120 ohm 1/4 watt resistor which is connected between pins 2 and 3 of a male XLR connector (DATA + and DATA -). This unit is inserted in the female XLR connector of the last unit in your daisy chain to terminate the line. Using a cable terminator (**ADJ part number Z-DMX/T**) will decrease the possibilities of erratic behavior.



Termination reduces signal errors and avoids signal transmission problems and interference. It is always advisable to connect a DMX terminal, (Resistance 120 Ohm 1/4 W) between PIN 2 (DMX-) and PIN 3 (DMX +) of the last fixture.

Figure 4

**5-Pin XLR DMX Connectors.** Some manufacturers use 5-pin DMX-512 data cables for DATA transmission in place of 3-pin. 5-pin DMX fixtures may be implemented in a 3-pin DMX line. When inserting standard 5-pin data cables in to a 3-pin line, a cable adaptor must be used. These adaptors are readily available at most electric stores. The chart below details a proper cable conversion.

3-Pin XLR to 5-Pin XLR Conversion		
Conductor	3-Pin XLR Female (Out)	5-Pin XLR Male (In)
Ground/Shield	Pin 1	Pin 1
Data Compliment (- signal)	Pin 2	Pin 2
Data True (+ signal)	Pin 3	Pin 3
Not Used		Pin 4 - Do Not Use
Not Used		Pin 5 - Do Not Use

With this feature you can connect the fixtures to one another using the power input and output sockets.

The maximum number of fixtures that can be connected in this manner is as follows:

- 8 fixtures maximum @ 120V
- 16 fixtures maximum @230V

After this quantity has been exceeded, a new power outlet will be required in order to accommodate additional devices.

All connected fixtures must be of the same make and model type. **DO NOT** mix fixtures.

**Universal DMX Control:** This function allows you to use a universal DMX-512 controller. A DMX controller allows you to create unique programs tailored to your individual needs.

- The Vizi Beam RXONE has two DMX channel modes: a 15 channel mode and 17 channel mode. See the **Channel Mode** sections of this manual for detailed descriptions of the DMX traits.
- To control your fixture in DMX mode, follow the procedures shown in the **DMX Set Up** section of this manual as well as the set-up specifications that are included with your DMX controller.
- Follow the instructions shown in the **System Menu** section of this manual to select your desired DMX channel mode and to set your desired DMX address.
- Use the controller's faders to control the various DMX fixture traits.
- For longer cable runs (more than a 100 feet) use a terminator on the last fixture.
- For help operating in DMX mode consult the manual included with your DMX controller.



Channel	Value	Function
1	0 - 255	PAN MOVEMENT
2	0 - 255	TILT MOVEMENT
3	0 - 2	COLOR WHEEL WHITE
	3 - 4	WHITE & RED
	5 - 6	RED
	7 - 8	RED & BLUE
	9 - 10	BLUE
	11 - 12	BLUE & GREEN
	13 - 14	GREEN
	15 - 16	GREEN & LIGHT YELLOW
	17 - 18	LIGHT YELLOW
	19 - 21	LIGHT YELLOW & ORANGE
	22 - 23	ORANGE
	24 - 25	ORANGE & MAGENTA
	26 - 27	MAGENTA
	28 - 29	MAGENTA & LIGHT BLUE
	30 - 31	LIGHT BLUE
	32 - 33	LIGHT BLUE & YELLOW
	34 - 35	YELLOW
	36 - 37	YELLOW & LIGHT GREEN
	38 - 39	LIGHT GREEN
	40 - 42	LIGHT GREEN & PURPLE
	43 - 44	PURPLE
	45 - 46	PURPLE & PINK
	47 - 48	PINK
	49 - 50	PINK & MEDIUM YELLOW
	51 - 52	MEDIUM YELLOW
	53 - 54	MEDIUM YELLOW & CTB
	55 - 56	CTB
	57 - 58	CTB & UV
	59 - 60	UV
	61 - 63	UV & WHITE
	64 - 127	OPEN
	128 - 189	CLOCKWISE ROTATION FAST - SLOW
	190 - 193	NO ROTATION
	194 - 255	COUNTER-CLOCKWISE ROTATION SLOW - FAST

Channel	Value	Function
4		GOBO WHEEL
	0 - 3	OPEN
	4 - 7	GOBO 1
	8 - 11	GOBO 2
	12 - 15	GOBO 3
	16 - 19	GOBO 4
	20 - 23	GOBO 5
	24 - 27	GOBO 6
	28 - 31	GOBO 7
	32 - 35	GOBO 8
	36 - 39	GOBO 9
	40 - 43	GOBO 10
	44 - 47	GOBO 11
	48 - 51	GOBO 12
	52 - 55	GOBO 13
	56 - 59	GOBO 14
	60 - 63	GOBO 15
	64 - 68	GOBO 1 SHAKE
	69 - 72	GOBO 2 SHAKE
	73 - 76	GOBO 3 SHAKE
	77 - 80	GOBO 4 SHAKE
	81 - 84	GOBO 5 SHAKE
	85 - 89	GOBO 6 SHAKE
	90 - 93	GOBO 7 SHAKE
	94 - 97	GOBO 8 SHAKE
	98 - 101	GOBO 9 SHAKE
	102 - 105	GOBO 10 SHAKE
	106 - 110	GOBO 11 SHAKE
	111 - 114	GOBO 12 SHAKE
	115 - 118	GOBO 13 SHAKE
119 - 122	GOBO 14 SHAKE	
123 - 127	GOBO 15 SHAKE	
128 - 189	COUNTER-CLOCKWISE ROTATION FAST - SLOW	
190 - 193	NO ROTATION	
194 - 255	CLOCKWISE ROTATION SLOW - FAST	

Gobo's

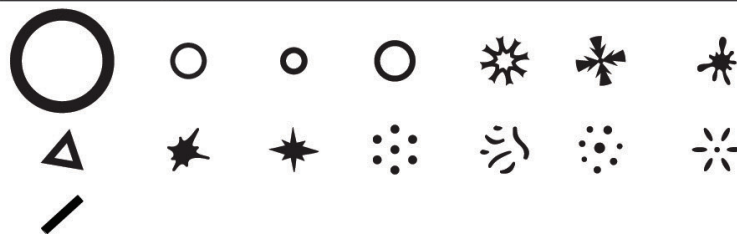

Channel	Value	Function
5	0 - 7	SHUTTER & STROBE
	8 - 15	SHUTTER CLOSED
	16 - 131	SHUTTER OPEN
	132 - 167	STROBING SLOW - FAST
	168 - 203	SLOW OPEN - FAST CLOSE
	204 - 239	FAST CLOSE - SLOW OPEN
	240 - 247	FAST OPEN - SLOW CLOSE
	248 - 255	RANDOM STROBE
		OPEN
6	0 - 255	MASTER DIMMER 0% - 100%
7	0 - 7	PRISM
	8 - 127	OPEN
	128 - 132	PRISM ROTATION
	133 - 137	PRISM ROTATION EFFECT 1
	138 - 141	PRISM ROTATION EFFECT 2
	142 - 146	PRISM ROTATION EFFECT 3
	147 - 150	PRISM ROTATION EFFECT 4
	151 - 155	PRISM ROTATION EFFECT 5
	156 - 159	PRISM ROTATION EFFECT 6
	160 - 164	PRISM ROTATION EFFECT 7
	165 - 168	PRISM ROTATION EFFECT 8
	169 - 173	PRISM ROTATION EFFECT 9
	174 - 177	PRISM ROTATION EFFECT 10
	178 - 182	PRISM ROTATION EFFECT 11
	183 - 187	PRISM ROTATION EFFECT 12
	188 - 191	PRISM ROTATION EFFECT 13
	192 - 196	PRISM ROTATION EFFECT 14
	197 - 200	PRISM ROTATION EFFECT 15
	201 - 205	PRISM ROTATION EFFECT 16
	206 - 209	PRISM ROTATION EFFECT 17
	210 - 214	PRISM ROTATION EFFECT 18
	215 - 218	PRISM ROTATION EFFECT 19
	219 - 223	PRISM ROTATION EFFECT 20
	224 - 227	PRISM ROTATION EFFECT 21
	228 - 232	PRISM ROTATION EFFECT 22
	233 - 236	PRISM ROTATION EFFECT 23
	237 - 241	PRISM ROTATION EFFECT 24
	242 - 246	PRISM ROTATION EFFECT 25
	247 - 250	PRISM ROTATION EFFECT 26
251 - 255	PRISM ROTATION EFFECT 27	
	PRISM ROTATION EFFECT 28	

Channel	Value	Function
8	0 - 127	PRISM ROTATION INDEXING
	128 - 190	CLOCKWISE ROTATION FAST - SLOW
	191 - 192	NO ROTATION
	193 - 255	COUNTER-CLOCKWISE ROTATION SLOW - FAST
9	0 - 7	FROST
	8 - 255	NO FUNCTION
		0% - 100%
10	0 - 7	PAN/TILT MACROS OFF
	8 - 15	MACRO 1
	16 - 23	MACRO 2
	24 - 31	MACRO 3
	32 - 39	MACRO 4
	40 - 47	MACRO 5
	48 - 55	MACRO 6
	56 - 63	MACRO 7
	64 - 71	MACRO 8
	72 - 79	MACRO 9
	80 - 87	MACRO 10
	88 - 95	MACRO 11
	96 - 103	MACRO 12
	104 - 111	MACRO 13
	112 - 119	MACRO 14
	120 - 127	MACRO 15
	128 - 135	MACRO 16
	136 - 143	MACRO 17
	144 - 151	MACRO 18
	152 - 159	MACRO 19
	160 - 167	MACRO 20
	168 - 175	MACRO 21
	176 - 183	MACRO 22
	184 - 191	MACRO 23
	192 - 199	MACRO 24
	200 - 207	MACRO 25
	208 - 215	MACRO 26
	216 - 223	MACRO 27
	224 - 231	MACRO 28
	232 - 239	MACRO 29
	240 - 247	MACRO 30
248 - 255	MACRO 31	

Channel	Value	Function
11	0 - 255	PAN/TILT MACRO SPEED FAST - SLOW
12	0 - 254 255	COLOR TIME FAST - SLOW FAST
13	0 - 254 255	GOBO TIME FAST - SLOW FAST
14	0 - 255	PAN/TILT SPEED FAST - SLOW
15	0 - 49 50 - 59 60 - 69 70 - 79 80 - 89 90 - 99 100 - 109 110 - 119 120 - 129 130 - 139 140 - 149 150 - 159 160 - 169 170 - 179 180 - 199 200 - 209 210 - 219 220 - 229 230 - 239 240 - 255	SPECIAL FUNCTIONS NO FUNCTION PAN/TILT FAST MODE PAN/TILT NORMAL MODE ENABLE BLACKOUT WITH PAN/TILT MOVEMENT DISABLE BLACKOUT WITH PAN/TILT MOVEMENT ENABLE BLACKOUT WITH COLOR CHANGE DISABLE BLACKOUT WITH COLOR CHANGE ENABLE BLACKOUT WITH GOBO CHANGE DISABLE BLACKOUT WITH GOBO CHANGE LAMP ON PAN/TILT MOTOR RESET COLOR MOTOR RESET GOBO MOTOR RESET SHUTTER/PRISM/R PRISM/FROST RESET NO FUNCTION RESET ALL ENABLE BLACKOUT WITH PAN/TILT/GOBO/ COLOR CHANGE DISABLE BLACKOUT WITH PAN/TILT/GOBO/ COLOR CHANGE LAMP OFF NO FUNCTION



Channel	Value	Function
1	0 - 255	PAN MOVEMENT
2	0 - 255	PAN FINE
3	0 - 255	TILT MOVEMENT
4	0 - 255	TILT FINE
5		COLOR WHEEL
	0 - 2	WHITE
	3 - 4	WHITE & RED
	5 - 6	RED
	7 - 8	RED & BLUE
	9 - 10	BLUE
	11 - 12	BLUE & GREEN
	13 - 14	GREEN
	15 - 16	GREEN & LIGHT YELLOW
	17 - 18	LIGHT YELLOW
	19 - 21	LIGHT YELLOW & ORANGE
	22 - 23	ORANGE
	24 - 25	ORANGE & MAGENTA
	26 - 27	MAGENTA
	28 - 29	MAGENTA & LIGHT BLUE
	30 - 31	LIGHT BLUE
	32 - 33	LIGHT BLUE & YELLOW
	34 - 35	YELLOW
	36 - 37	YELLOW & LIGHT GREEN
	38 - 39	LIGHT GREEN
	40 - 42	LIGHT GREEN & PURPLE
	43 - 44	PURPLE
	45 - 46	PURPLE & PINK
	47 - 48	PINK
	49 - 50	PINK & MEDIUM YELLOW
	51 - 52	MEDIUM YELLOW
	53 - 54	MEDIUM YELLOW & CTB
	55 - 56	CTB
	57 - 58	CTB & UV
	59 - 60	UV
	61 - 63	UV & WHITE
	64 - 127	OPEN
	128 - 189	CLOCKWISE ROTATION FAST - SLOW
	190 - 193	NO ROTATION
	194 - 255	COUNTER-CLOCKWISE ROTATION SLOW - FAST

Channel	Value	Function
6		GOBO WHEEL
	0 - 3	OPEN
	4 - 7	GOBO 1
	8 - 11	GOBO 2
	12 - 15	GOBO 3
	16 - 19	GOBO 4
	20 - 23	GOBO 5
	24 - 27	GOBO 6
	28 - 31	GOBO 7
	32 - 35	GOBO 8
	36 - 39	GOBO 9
	40 - 43	GOBO 10
	44 - 47	GOBO 11
	48 - 51	GOBO 12
	52 - 55	GOBO 13
	56 - 59	GOBO 14
	60 - 63	GOBO 15
	64 - 68	GOBO 1 SHAKE
	69 - 72	GOBO 2 SHAKE
	73 - 76	GOBO 3 SHAKE
	77 - 80	GOBO 4 SHAKE
	81 - 84	GOBO 5 SHAKE
	85 - 89	GOBO 6 SHAKE
	90 - 93	GOBO 7 SHAKE
	94 - 97	GOBO 8 SHAKE
	98 - 101	GOBO 9 SHAKE
	102 - 105	GOBO 10 SHAKE
	106 - 110	GOBO 11 SHAKE
	111 - 114	GOBO 12 SHAKE
	115 - 118	GOBO 13 SHAKE
	119 - 122	GOBO 14 SHAKE
	123 - 127	GOBO 15 SHAKE
128 - 189	COUNTER-CLOCKWISE ROTATION FAST - SLOW	
190 - 193	NO ROTATION	
194 - 255	CLOCKWISE ROTATION SLOW - FAST	

Gobo's

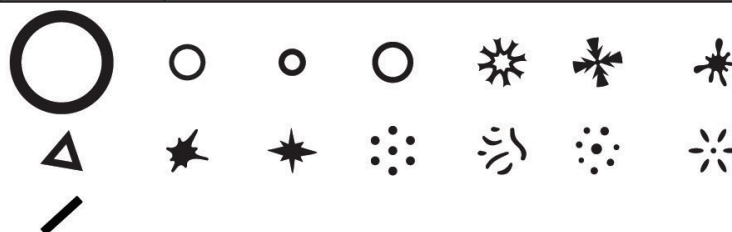

Channel	Value	Function
7	0 - 7	SHUTTER & STROBE
	8 - 15	SHUTTER CLOSED
	16 - 131	SHUTTER OPEN
	132 - 167	STROBING SLOW - FAST
	168 - 203	SLOW OPEN - FAST CLOSE
	204 - 239	FAST CLOSE - SLOW OPEN
	240 - 247	FAST OPEN - SLOW CLOSE
	248 - 255	RANDOM STROBE
		OPEN
8	0 - 255	MASTER DIMMER 0% - 100%
9	0 - 7	PRISM
	8 - 127	OPEN
	128 - 132	PRISM ROTATION
	133 - 137	PRISM ROTATION EFFECT 1
	138 - 141	PRISM ROTATION EFFECT 2
	142 - 146	PRISM ROTATION EFFECT 3
	147 - 150	PRISM ROTATION EFFECT 4
	151 - 155	PRISM ROTATION EFFECT 5
	156 - 159	PRISM ROTATION EFFECT 6
	160 - 164	PRISM ROTATION EFFECT 7
	165 - 168	PRISM ROTATION EFFECT 8
	169 - 173	PRISM ROTATION EFFECT 9
	174 - 177	PRISM ROTATION EFFECT 10
	178 - 182	PRISM ROTATION EFFECT 11
	183 - 187	PRISM ROTATION EFFECT 12
	188 - 191	PRISM ROTATION EFFECT 13
	192 - 196	PRISM ROTATION EFFECT 14
	197 - 200	PRISM ROTATION EFFECT 15
	201 - 205	PRISM ROTATION EFFECT 16
	206 - 209	PRISM ROTATION EFFECT 17
	210 - 214	PRISM ROTATION EFFECT 18
	215 - 218	PRISM ROTATION EFFECT 19
	219 - 223	PRISM ROTATION EFFECT 20
	224 - 227	PRISM ROTATION EFFECT 21
	228 - 232	PRISM ROTATION EFFECT 22
	233 - 236	PRISM ROTATION EFFECT 23
	237 - 241	PRISM ROTATION EFFECT 24
	242 - 246	PRISM ROTATION EFFECT 25
247 - 250	PRISM ROTATION EFFECT 26	
251 - 255	PRISM ROTATION EFFECT 27	
	PRISM ROTATION EFFECT 28	



Channel	Value	Function
10	0 - 127	PRISM ROTATION INDEXING
	128 - 190	CLOCKWISE ROTATION FAST - SLOW
	191 - 192	NO ROTATION
	193 - 255	COUNTER-CLOCKWISE ROTATION SLOW - FAST
11	0 - 7	FROST
	8 - 255	NO FUNCTION
		0% - 100%
12	0 - 7	PAN/TILT MACROS OFF
	8 - 15	MACRO 1
	16 - 23	MACRO 2
	24 - 31	MACRO 3
	32 - 39	MACRO 4
	40 - 47	MACRO 5
	48 - 55	MACRO 6
	56 - 63	MACRO 7
	64 - 71	MACRO 8
	72 - 79	MACRO 9
	80 - 87	MACRO 10
	88 - 95	MACRO 11
	96 - 103	MACRO 12
	104 - 111	MACRO 13
	112 - 119	MACRO 14
	120 - 127	MACRO 15
	128 - 135	MACRO 16
	136 - 143	MACRO 17
	144 - 151	MACRO 18
	152 - 159	MACRO 19
	160 - 167	MACRO 20
	168 - 175	MACRO 21
	176 - 183	MACRO 22
	184 - 191	MACRO 23
	192 - 199	MACRO 24
	200 - 207	MACRO 25
	208 - 215	MACRO 26
	216 - 223	MACRO 27
	224 - 231	MACRO 28
	232 - 239	MACRO 29
	240 - 247	MACRO 30
248 - 255	MACRO 31	

Channel	Value	Function
13	0 - 255	PAN/TILT MACRO SPEED FAST - SLOW
14	0 - 254 255	COLOR TIME FAST - SLOW FAST
15	0 - 254 255	GOBO TIME FAST - SLOW FAST
16	0 - 255	PAN/TILT SPEED FAST - SLOW
17	0 - 49 50 - 59 60 - 69 70 - 79 80 - 89 90 - 99 100 - 109 110 - 119 120 - 129 130 - 139 140 - 149 150 - 159 160 - 169 170 - 179 180 - 199 200 - 209 210 - 219 220 - 229 230 - 239 240 - 255	SPECIAL FUNCTIONS NO FUNCTION PAN/TILT FAST MODE PAN/TILT NORMAL MODE ENABLE BLACKOUT WITH PAN/TILT MOVEMENT DISABLE BLACKOUT WITH PAN/TILT MOVEMENT ENABLE BLACKOUT WITH COLOR CHANGE DISABLE BLACKOUT WITH COLOR CHANGE ENABLE BLACKOUT WITH GOBO CHANGE DISABLE BLACKOUT WITH GOBO CHANGE LAMP ON PAN/TILT MOTOR RESET COLOR MOTOR RESET GOBO MOTOR RESET SHUTTER/PRISM/R PRISM/FROST RESET NO FUNCTION RESET ALL ENABLE BLACKOUT WITH PAN/TILT/GOBO/ COLOR CHANGE DISABLE BLACKOUT WITH PAN/TILT/GOBO/ COLOR CHANGE LAMP OFF NO FUNCTION

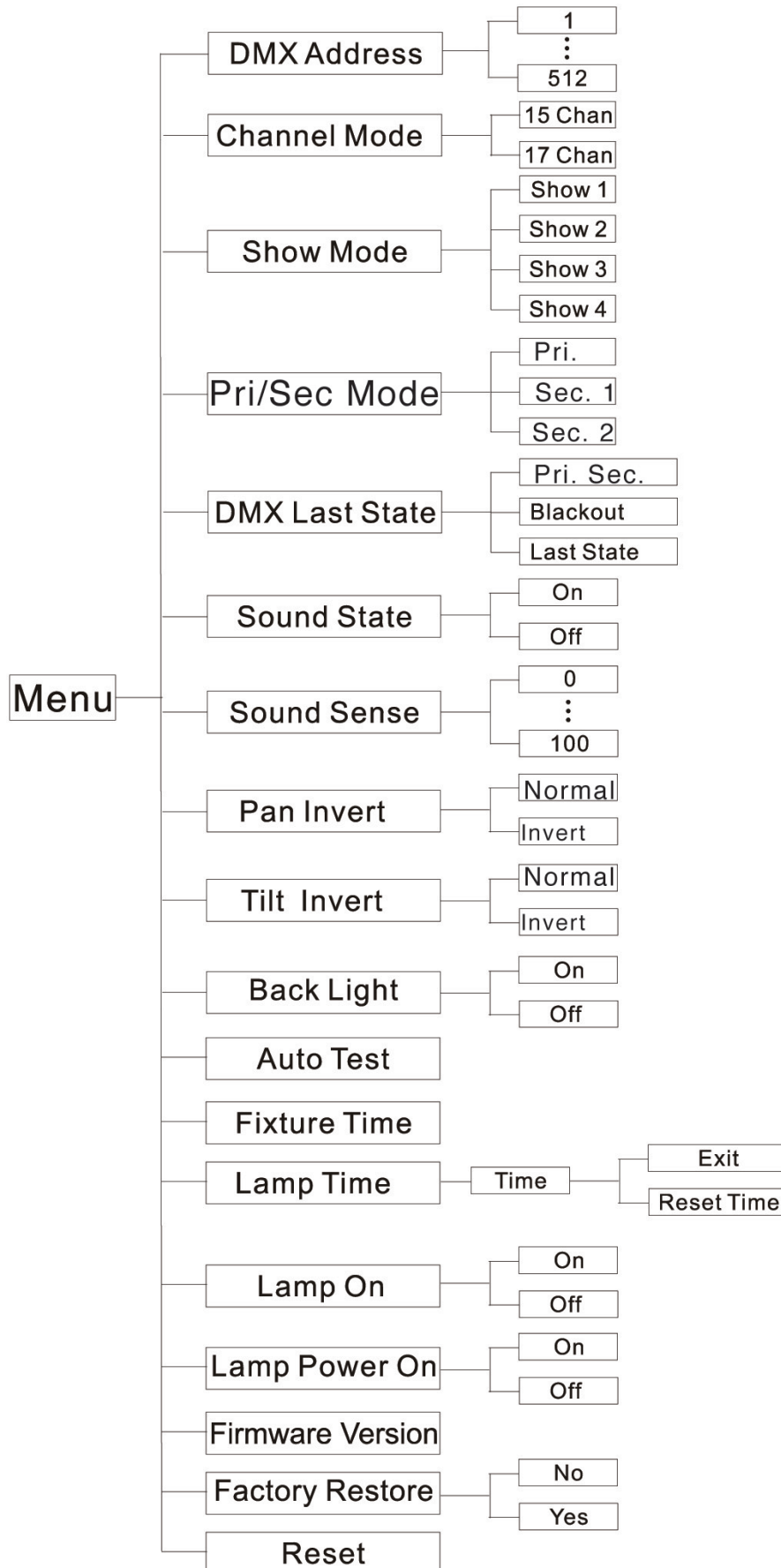

**System Menu:** When making adjustments press **ENTER** to confirm your setup then press and hold the **MENU** button for at least 3 seconds. To exit without making any adjustments press the **MENU** button. The display will lock after 30 seconds, press the **MENU** button for 3 seconds to unlock.

#### **DMX Address - Set the DMX Address.**

1. Press the MENU button until “DMX Address” is displayed, and press ENTER.
2. “X” will now be displayed, where “X” represents the displayed address. Press the UP or DOWN buttons to find your desired address.
3. Press ENTER to confirm, and then press and hold the MENU button for at least three seconds to assign.

#### **Channel Mode - This will let you select your desired DMX Channel mode.**

1. Press the MENU button until “Channel Mode” is displayed, and press ENTER.
2. “X Chan” will now be displayed, where “X” represents the displayed DMX channel mode. Press the UP or DOWN buttons to find your desired Channel mode.
3. Press ENTER to confirm.

#### **Show Mode - Show modes 1 - 4 (Factory Shows).**

1. Press the MENU button until “Show Mode” is displayed, and press ENTER.
2. “Show X” will now be displayed, “X” representing a number between 1-4. Press the UP or DOWN buttons to find your desired show and press ENTER to confirm. After pressing ENTER, press and hold the MENU button for at least 3 seconds to activate.

#### **Pri/Sec Mode - This will let you set unit as a primary or secondary in primary/secondary mode.**

1. Press the MENU button until “Pri/Sec Mode” is displayed, and press ENTER. Either “Pri”, “Sec 1” or “Sec 2” will be displayed.
2. Press the UP or DOWN buttons until your desired setting is displayed, then press ENTER to confirm.

**NOTE:** In a Primary/Secondary configuration you can make one fixture the Primary and then set the next fixture to “Sec 2”, the fixtures will now have contrast movement to each other.

#### **DMX Last State - This mode defines how the fixture will behave in the event that the DMX signal is lost or interrupted.**

1. Press the MENU button until “DMX Last State” is displayed, and press ENTER.
2. Either “Pri Sec”, “Blackout”, or “Last State” will be displayed. Choose an operating mode you would like the unit to start up in when power is applied or the DMX signal is lost.
  - Primary/Secondary - If the DMX signal is lost or power is applied, the unit will automatically go into Primary/Secondary mode.
  - Blackout - If the DMX signal is lost or power is applied, the unit will automatically go into stand by mode.
  - Last State - If the DMX signal is lost the fixture will stay in the last DMX set up. If power is applied and this mode is set, the unit will automatically go into the last DMX set up.
3. Press ENTER to confirm your desired set up.

**Sound State - In this mode the unit will run in sound active mode.**

1. Press the MENU button until “Sound State” is displayed, and press ENTER.
2. Either “On” or “Off” will now be displayed. Use the UP or DOWN buttons to toggle between “On” and “Off”.
3. Press ENTER to confirm your selection, then press and hold the MENU button to activate.

**Sound Sense - In this mode you can adjust the sound sensitivity of the sound active mode.**

1. Press the MENU button until “Sound Sense” is displayed, and press ENTER.
2. Press the UP or DOWN buttons to adjust the sensitivity level. The sensitivity level can be adjusted between 0 (the lowest) and 100 (most sensitive).
3. Press ENTER to set you desired level.

**Pan Invert - Pan Inversion**

1. Press the MENU button until “Pan Invert” is displayed, and press ENTER. Either “Invert” or “Normal” will be displayed.
2. To activate the Pan inversion press the UP or DOWN buttons until “Invert” is displayed, and press ENTER to confirm. To deactivate Pan inversion, select “Normal” and press Enter.

**Tilt Invert - Tilt Inversion**

1. Press the MENU button until “Tilt Invert” is displayed, and press ENTER. Either “Invert” or “Normal” will be displayed.
2. To activate the Tilt inversion press the UP or DOWN buttons until “Invert” is displayed, and press ENTER to confirm. To deactivate Tilt inversion, select “Normal” and press Enter.

**Back Light - With this function you can make the backlight automatically turn off after one minute.**

1. Press the MENU button until “Back Light” is displayed, and press ENTER.
2. Either “On” or “Off” will now be displayed. Press the UP or DOWN buttons to select “On” to keep the backlight on at all times, or “Off” to allow the backlight to turn off after 1 minute. Press any button to turn the backlight on again.

**Auto Test - This function will run a self test program.**

1. Press the MENU button until “Auto Test” is displayed, and press ENTER.
2. The fixture will now run a self test. Press the MENU button to exit.

**Fixture Time - With this function you can display the running time of the unit.**

1. Press the MENU button until “Fixture Time” is displayed, and press ENTER.
2. The running time of the fixture will now be displayed. Press MENU to exit.

**Lamp Time - This function will allow you to view the running lifetime of the installed lamp. The function also lets you reset the lamp running time when a new lamp as been installed.**

1. Press the MENU button until “Lamp Time” is displayed, and press ENTER. The current lamp time will be displayed.
2. Press ENTER again, and “Reset” will be displayed. Press ENTER to reset the lamp time to 0. Only reset the lamp time when installing a new lamp. If you don't wish to reset the lamp time press the MENU button.

**Lamp On - This function will allow the lamp to be automatically switched ON when power is applied to the fixture.**

1. Press the MENU button until “Lamp On” is displayed, and press ENTER. Either “On” or “Off” will be displayed.
2. To turn “on” the lamp when power is applied to the fixture, press the UP or DOWN buttons until “On” is displayed, press ENTER to confirm. To turn “off” the automatic Lamp-On function, select “Off” and press Enter.

**Lamp Power On - This function will allow you to switch the lamp power on/off.**

1. Press the MENU button until “Lamp Power On” is displayed, and press ENTER. Either “On” or “Off” will be displayed.
2. To turn “on” the lamp press the UP or DOWN buttons until “On” is displayed, press ENTER to confirm. To turn “off” the lamp, select “Off” and press Enter.

**Firmware Version - This will display the firmware/software version.**

1. Press the MENU button until “Firmware Version” is displayed. Press the ENTER button and the firmware/software version will be displayed.
2. Press the MENU button to leave this function.

**Factory Restore - This function will restore all factory settings.**

1. Press the MENU button until “Factory Restore” is displayed, and press ENTER. Either “Yes” or “No” will be displayed.
2. To restore factory settings press the UP or DOWN buttons until “Yes” is displayed, and press ENTER to confirm. If you do not wish restore the settings, select “No” and press Enter.

**Reset - Use this function to reset the motors.**

1. Press the MENU button until “Reset” is displayed, and press ENTER.
2. The fixture will now reset.

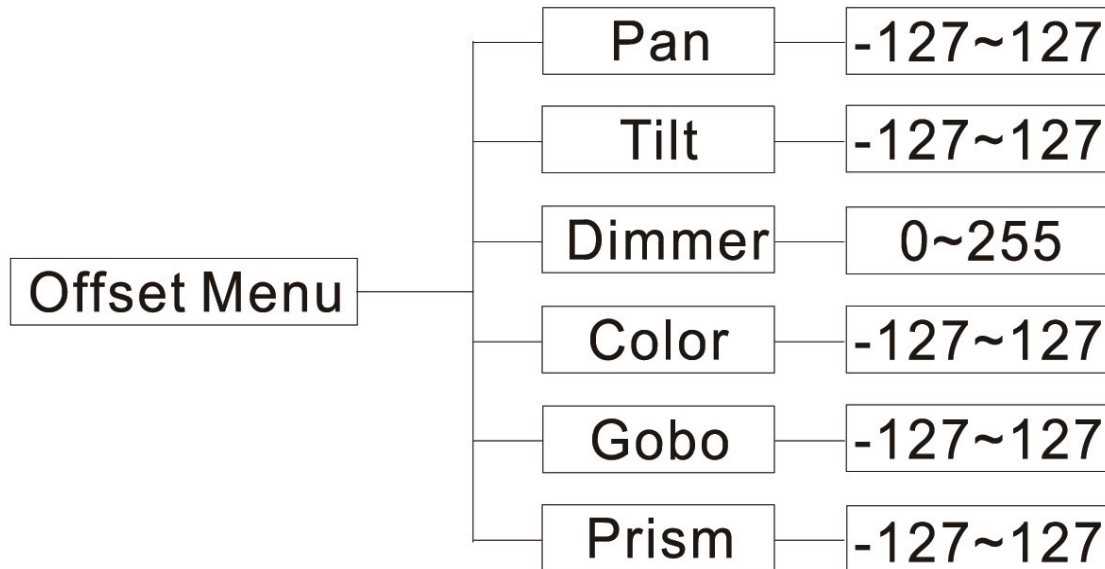

To enter the Offset Menu, press the ENTER button for at least 5 seconds. In this submenu you are able to adjust the home position of the pan, tilt, shutter, color wheel, gobo, and prism.

#### **Pan - Adjustment of the pan home position.**

1. Press the ENTER button for at least 5 seconds, then press the UP or DOWN buttons so that “Pan” is displayed. Press ENTER.
2. Use the UP and DOWN buttons to make your adjustments, and then press ENTER to confirm. Press the MENU button for one second to exit.

#### **TILT - Adjustment of the tilt home position.**

1. Press the ENTER button for at least 5 seconds, then press the UP or DOWN buttons so that “Tilt” is displayed. Press ENTER.
2. Use the UP and DOWN buttons to make your adjustments, and then press ENTER to confirm. Press the MENU button for one second to exit.

#### **Dimmer - Setting adjustment for the Shutter.**

1. Press the ENTER button for at least 5 seconds, then press the UP or DOWN buttons so that “Dimmer” is displayed. Press ENTER.
2. Use the UP and DOWN buttons to make your adjustments, and then press ENTER to confirm. Press the MENU button for one second to exit.

#### **Color - Setting adjustment for the color wheel.**

1. Press the ENTER button for at least 5 seconds, then press the UP or DOWN buttons so that “Color” is displayed. Press ENTER.
2. Use the UP and DOWN buttons to make your adjustments, and then press ENTER to confirm. Press the MENU button for one second to exit.



**Gobo - Setting adjustment for the gobo wheel.**

1. Press the ENTER button for at least 5 seconds, then press the UP or DOWN buttons so that “Gobo” is displayed. Press ENTER.
2. Use the UP and DOWN buttons to make your adjustments, and then press ENTER to confirm. Press the MENU button for one second to exit.

**Prism - Setting adjustment for the 1st prism.**

1. Press the ENTER button for at least 5 seconds, then press the UP or DOWN buttons so that “Prism” is displayed. Press ENTER.
2. Use the UP and DOWN buttons to make your adjustments, and then press ENTER to confirm. Press the MENU button for one second to exit.

**Sound Active Mode: This mode allows either single unit or several units linked together to run to the beat of the music.**

1. Press the MENU button until “Sound State” is displayed, and press ENTER.
2. Press the UP or DOWN buttons so that “ON” is displayed and press ENTER.
3. Press the MENU button until “Sound Sense” is displayed, and press ENTER.
4. Use the UP and DOWN buttons to adjust the sound sensitivity, and press ENTER once you have found your desired sensitivity level.

**Show Mode: This mode allows either a single unit or several units linked together to run one of four shows that you choose.**

1. Press the MENU button until “Show Mode” is displayed, and press ENTER.
2. Press the UP or DOWN buttons to find your desired show, and press ENTER.

**Primary-Secondary Operation:** This function will allow you to link up to 16 units together and operate without a controller. The units will be sound activated. In Primary-Secondary operation, one unit will act as the controlling unit and the others will react to the controlling units programs. Any unit can act as a Primary or as a Secondary.

1. Using approved DMX data cables, daisy chain your units together via the XLR connector on the rear face of each unit. Remember the Male XLR connector is the input and the Female XLR connector is the output. The first unit in the chain (primary) will use the female XLR connector only, while the last unit in the chain will use the male XLR connector only. For longer cable runs we suggest installing a terminator at the last fixture.
2. On the Primary unit press the MENU button until “Pri/Sec” is displayed, and press ENTER. Use the UP and DOWN buttons to scroll to the “Pri” setting and press ENTER.
3. After setting the Primary unit to the primary setting, find and set the desired operating mode.
4. For each secondary unit, press the MENU button until “Pri/Sec” is displayed, and press ENTER. Choose either “Sec 1” or “Sec 2” and press ENTER.
5. The secondary units will now follow the primary unit.



The **UC IR (sold separately)** infrared remote gives you control of various functions (See below). To control the fixture you must aim the remote at the front of the fixture. Maximum range is 30 feet. Please see below for IR functions.

The **Airstream IR (sold separately)** remote transmitter plugs into the headphone jack of your iOS phone or tablet. To control your IR fixture you must raise the volume to the maximum on your iOS phone or tablet and aim the transmitter at the fixture sensor. Maximum range is 15 feet. After you have purchased the Airstream IR transmitters, the app is a free download from the app store for your iOS phone or tablet. The app comes with 3 pages of control depending on the fixture you are using. Please see below for IR functions including the corresponding app page.

### **Works with App page 1.**

**STAND BY** - Pressing this button will blackout the fixture. Press the button again to return to the initial state.

**FULL ON** - Hold this button down to fully light up the unit. When the button is released, the unit will return to its previous state.

**FADE/GOBO** - This button activates gobo selection. Press this button and use buttons 1-9 to find your desired gobo.

**“DIMMER +” and “DIMMER -”** - These buttons are used to adjust the output intensity in static color mode.

**STROBE** - Press and hold this button for strobing.

**COLOR** - This button activates color selection. Press this button and use buttons 1-9 to find your desired color.

**1-9** - Use buttons 1-9 to select your desired color when color selection is active, your desired gobo when gobo selection is active, and your desired show when show mode is active.

**SOUND ON & OFF** - Use the buttons to activate and deactivate sound active mode.

**SHOW 0** - Press this button to activate show mode. Use buttons 1-4 to find your desired show.

**Caution:** Always replace with the exact same type lamp and fuse, unless otherwise specified by an authorized ADJ® service technician. Replacing with anything other than the specified part can damage your unit and will void your manufacturer's warranty.

**Warning:** If you continue to blow lamps or fuses, STOP using the unit immediately! Contact customer support for further instructions. The unit may need to be returned for servicing. Continuing to use the unit may cause serious damage.

**Fuse Replacement:** First unplug the power. The fuse holder is located next to the power connection. Using a phillips head screw driver unscrew the fuse holder. Remove the bad fuse and replace with a new one.

**Lamp Replacement:** **Caution! Never attempt to change the lamp while the fixture is plugged in. Always disconnect the main power and allow the unit at least 15 minutes to cool before attempting to replace the lamp. Please see the "Important Discharge Lamp Warnings" section of this manual for important information regarding the discharge lamp. See the following Lamp Replacement section of this manual for detailed lamp replacement instructions. Be sure to follow the proper handling procedures that deal with discharge lamps.**



Replacing the lamp is relatively easy. Unplug the unit from its power source. Allow the unit 15 minutes to cool down. Remove the shell that says “Lamp Access” on the rear. Start by unscrewing the four phillips screws that hold the shell in place. Once the screws are unscrewed remove the shell. You will now have access to the lamp.

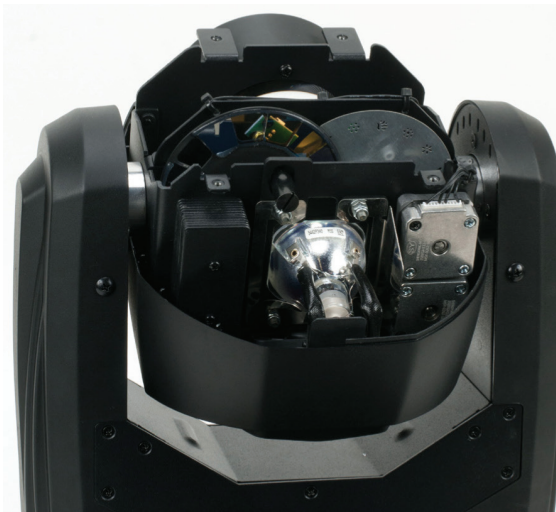

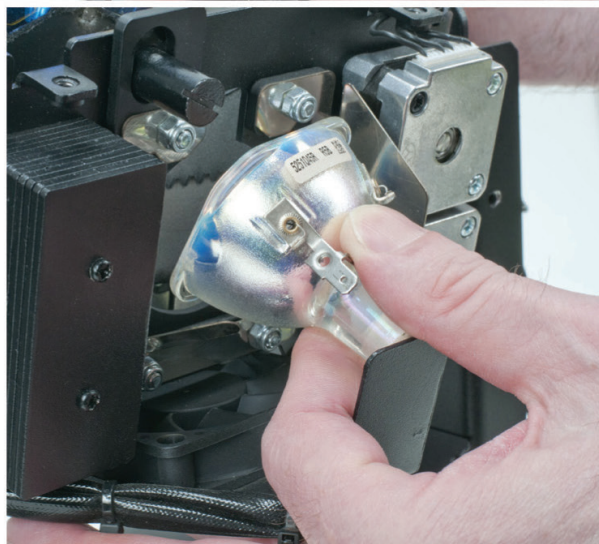
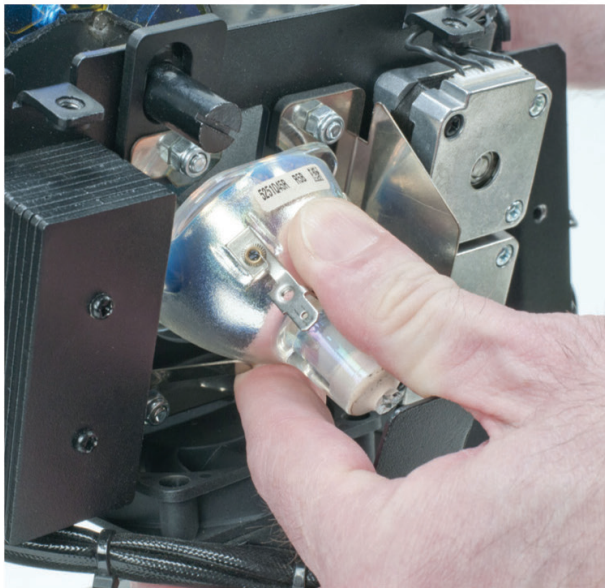

Carefully disconnect the two wires that are connected to the lamp's reflector. Firmly grab the moving head to hold it in place. Gently press the lamp down, and pull the top of the lamp out of the lamp holder. Note: Never touch the lamp located within the reflector with your bare hands.

Replace the lamp by setting the lamp into the two bottom brackets, gently press the lamp down, and insert the top of the lamp into the lamp frame.

**Fixture Cleaning:** Due to fog residue, smoke, and dust, cleaning the internal and external optical lenses and mirror should be carried out periodically to optimize light output. Cleaning frequency depends on the environment in which the fixture operates (i.e. smoke, fog residue, dust, dew). In heavy club use, cleaning on a monthly basis is recommended. Periodic cleaning will ensure longevity and crisp output.

- Use normal glass cleaner and a soft cloth to wipe down the outside casing.
- Use a brush to wipe down the cooling vents and fan grill.
- Clean the external optics and mirror with glass cleaner and a soft cloth every 20 days.
- Clean the internal optics with glass cleaner and a soft cloth every 30-60 days.
- Always be sure to dry all parts completely before plugging the unit back in.

**Trouble Shooting:** Listed below are a few common problems that you may encounter, with solutions.

***Unit not responding to DMX:***

Check that the DMX cables are connected properly and are wired correctly (pin 3 is “hot”; on some other DMX devices pin 2 may be ‘hot’). Also, check that all cables are connected to the right connectors; it does matter which way the inputs and outputs are connected.

***No light output from the unit:***

- Make sure the lamp is “On”.
- Be sure the external fuse has not blown. The fuse is located at the rear panel of the unit.
- Remove the “Lamp Access” shell and be sure the two wires are connected to the lamp
- Be sure the fuse holder is completely and properly seated.

***Unit does not respond to sound:***

- Quiet or high pitched sounds will not activate the unit.
- Make sure that Sound Active mode is activated.



**MANUFACTURER'S LIMITED WARRANTY**

- A. ADJ Products, LLC hereby warrants, to the original purchaser, ADJ Products, LLC products to be free of manufacturing defects in material and workmanship for a prescribed period from the date of purchase (see specific warranty period on reverse). This warranty shall be valid only if the product is purchased within the United States of America, including possessions and territories. It is the owner's responsibility to establish the date and place of purchase by acceptable evidence, at the time service is sought.
- B. For warranty service you must obtain a Return Authorization number (RA#) before sending back the product—please contact ADJ Products, LLC Service Department at 800-322-6337. Send the product only to the ADJ Products, LLC factory. All shipping charges must be pre-paid. If the requested repairs or service (including parts replacement) are within the terms of this warranty, ADJ Products, LLC will pay return shipping charges only to a designated point within the United States. If the entire instrument is sent, it must be shipped in its original package. No accessories should be shipped with the product. If any accessories are shipped with the product, ADJ Products, LLC shall have no liability whatsoever for loss of or damage to any such accessories, nor for the safe return thereof.
- C. This warranty is void if the serial number has been altered or removed; if the product is modified in any manner which ADJ Products, LLC concludes, after inspection, affects the reliability of the product; if the product has been repaired or serviced by anyone other than the ADJ Products, LLC factory unless prior written authorization was issued to purchaser by ADJ Products, LLC; if the product is damaged because not properly maintained as set forth in the instruction manual.
- D. This is not a service contract, and this warranty does not include maintenance, cleaning or periodic check up. During the period specified above, ADJ Products, LLC will replace defective parts at its expense with new or refurbished parts, and will absorb all expenses for warranty service and repair labor by reason of defects in material or workmanship. The sole responsibility of ADJ Products, LLC under this warranty shall be limited to the repair of the product, or replacement thereof, including parts, at the sole discretion of ADJ Products, LLC. All products covered by this warranty were manufactured after August 15, 2012, and bear identifying marks to that effect.
- E. ADJ Products, LLC reserves the right to make changes in design and/or improvements upon its products without any obligation to include these changes in any products theretofore manufactured.

No warranty, whether expressed or implied, is given or made with respect to any accessory supplied with products described above. Except to the extent prohibited by applicable law, all implied warranties made by ADJ Products, LLC in connection with this product, including warranties of merchantability or fitness, are limited in duration to the warranty period set forth above. And no warranties, whether expressed or implied, including warranties of merchantability or fitness, shall apply to this product after said period has expired. The consumer's and/or Dealer's sole remedy shall be such repair or replacement as is expressly provided above; and under no circumstances shall ADJ Products, LLC be liable for any loss or damage, direct or consequential, arising out of the use of, or inability to use, this product.

This warranty is the only written warranty applicable to ADJ Products, LLC Products and supersedes all prior warranties and written descriptions of warranty terms and conditions heretofore published.

**MANUFACTURER'S LIMITED WARRANTY PERIODS**

- **Lighting Products = 1-year (365 days) Limited Warranty** (Such as: Special Effect Lighting, Intelligent Lighting, UV lighting, Strobes, Fog Machines, Bubble Machines, Mirror Balls, Par Cans, Trussing, Lighting Stands etc. excluding LED and lamps)
- **Laser Products = 1 Year (365 Days) Limited Warranty** (excluding laser diodes which have a 6 month limited warranty)
- **L.E.D. Products = 2-year (730 days) Limited Warranty** (excluding motors, PCB boards, and power supplies, which have a 1-year (365 day Limited Warranty) batteries which have a 180 day limited warranty). Only the L.E.D.s carry a 2-year warranty (**excluding StarTec Series which carries a 1 Year Limited Warranty**) **Note: 2 Year Warranty only applies to purchases within the United States.**
- **ADJ DMX Controllers = 2 Year (730 Days) Limited Warranty** (excluding faders and tact switches)

<b>Model:</b>	<b>Vizi Beam RXONE</b>
<b>Voltage:</b>	100~240V, 50/60Hz
<b>Lamp:</b>	Osram Sirius HRI 100W 1R Discharge* 9000K - 6000hr. Long Life
<b>LUX:</b>	76300 @ 10M, 33900 @ 15M
<b>Power Consumption:</b>	199W
<b>Dimensions:</b>	11" (L) x 8.75" (W) x 15.25" (H) 279mm x 225mm x 387mm
<b>Weight:</b>	20 Lbs. / 9.2 kgs.
<b>Colors:</b>	14 Plus White
<b>Gobos:</b>	15 Fixed Gobos + Spot
<b>Fuse:</b>	5A
<b>Control:</b>	DMX, Stand Alone, RDM (Remote Device Management)
<b>DMX:</b>	2 DMX Modes: 15 Channels & 17 Channels
<b>Warranty:</b>	1 Year (365 days)

\* This lamp has a 6000 hour life. Please see the **Important Discharge Lamp Warnings** section of this manual for detailed information.

**Auto Sensing Voltage:** This fixture contains an electronic ballast, which will automatically sense the voltage when it is plugged into the power source.

**Please Note:** Specifications and improvements in the design of this unit and this manual are subject to change without any prior written notice.

ADJ Products, LLC  
6122 S. Eastern Ave. Los Angeles, CA 90040 USA  
Tel: 323-582-2650 / Fax: 323-725-6100  
Web: [www.adj.com](http://www.adj.com) / E-mail: [info@adj.com](mailto:info@adj.com)

#### Follow Us On:



[facebook.com/americanadj](https://facebook.com/americanadj)  
[twitter.com/americanadj](https://twitter.com/americanadj)  
[youtube.com/adjlighting](https://youtube.com/adjlighting)

A.D.J. Supply Europe B.V.  
Junostraat 2  
6468 EW Kerkrade  
The Netherlands  
[service@adjgroup.eu](mailto:service@adjgroup.eu) / [www.adj.eu](http://www.adj.eu)  
Tel: +31 45 546 85 00 / Fax: +31 45 546 85 99

