



# PAR ZPI100 3K



## User Manual



©2020 ADJ Products, LLC all rights reserved. Information, specifications, diagrams, images, and instructions herein are subject to change without notice. ADJ Products, LLC logo and identifying product names and numbers herein are trademarks of ADJ Products, LLC. Copyright protection claimed includes all forms and matters of copyrightable materials and information now allowed by statutory or judicial law or hereinafter granted. Product names used in this document may be trademarks or registered trademarks of their respective companies and are hereby acknowledged. All non-ADJ Products, LLC brands and product names are trademarks or registered trademarks of their respective companies.

**ADJ Products, LLC** and all affiliated companies hereby disclaim any and all liabilities for property, equipment, building, and electrical damages, injuries to any persons, and direct or indirect economic loss associated with the use or reliance of any information contained within this document, and/or as a result of the improper, unsafe, insufficient and negligent assembly, installation, rigging, and operation of this product.

## DOCUMENT VERSION



Due to additional product features and/or enhancements, an updated version of this document may be available online.

Please check [www.adj.com](http://www.adj.com) for the latest revision/update of this manual before beginning installation and/or programming.

Date	Document Version	Software Version	DMX Channels	Notes
09/27/2017	1.0	1.0	1 / 2 / 3	Initial Release
01/02/2018	2.0	1.2	1 / 2 / 3 / 4	Added RDM protocol support, 4-ch DMX mode, Stage 2 dimmer curve, default settings system menu.
12/17/2020	3.0	1.6	No Change	Updated DMX Setup.

Europe Energy Saving Notice

Energy Saving Matters (EuP 2009/125/EC)

Saving electric energy is a key to help protecting the environment. Please turn off all electrical products when they are not in use. To avoid power consumption in idle mode, disconnect all electrical equipment from power when not in use. Thank you!

**Unpacking:** Thank you for purchasing the Par ZP100 3K by ADJ Products, LLC. Every Par ZP100 3K has been thoroughly tested and has been shipped in perfect operating condition. Carefully check the shipping carton for damage that may have occurred during shipping. If the carton appears to be damaged, carefully inspect your fixture for any damage and be sure all equipment necessary to operate the unit has arrived intact. In the event damage has been found or parts are missing, please contact our toll free customer support number for further instructions. Please do not return this unit to your dealer without contacting customer support first.

**Introduction:** The Par ZP100 3K is a DMX intelligent, zooming, LED par fixture. The Par ZP100 3K operates as a stand alone fixture. This fixture is suitable for theaters, studios, retail stores, and other similar locations. For best results use fog or special effects smoke to enhance the beams projections.

**Customer Support:** ADJ Products, LLC provides a toll free customer support line, to provide help and to answer any question should you encounter problems during your set up or initial operation. You may also visit us on the web at [www.adj.com](http://www.adj.com) for any comments or suggestions. Service Hours are Monday through Friday 8:00 a.m. to 4:30 p.m. Pacific Standard Time.

Voice: (323) 582-2650  
Fax: (323) 582-2941  
E-mail: [support@adj.com](mailto:support@adj.com)

**Warning!** To prevent or reduce the risk of electrical shock or fire, do not expose this unit to rain or moisture.

**Warning!** *This may cause severe eye damage. Avoid looking directly into the light source at all times!*

To optimize the performance of this product, please read these operating instructions carefully to familiarize yourself with the basic operations of this unit. These instructions contain important safety information regarding the use and maintenance of this unit. Please keep this manual with the unit, for future reference.

- DMX-512 Protocol Compatible (4 DMX Channel Modes: 1, 2, 3, or 4 channels)
- 5-Pin XLR In/Out Connections
- Power In/Out Connections
- 6 Dimmer Curve Modes
- Digital Display for Address and Function Setting
- Gamma Correction Adjustment
- Dimming Frequency Adjustment
- Multiple Unit Power Linking (see **Multiple Unit Power Linking** section)

The Par ZP100 3K carries a 2 year (730 days) limited warranty. Please fill out the enclosed warranty card to validate your purchase and warranty.

You may also register your product online at: [www.adj.com](http://www.adj.com).

All returned service items, whether under warranty or not, must be freight pre-paid and accompany a return authorization (R.A.) number. If the unit is under warranty you must provide a copy of your proof of purchase invoice. Please contact ADJ Products, LLC customer support for a R.A. number.

**Caution!** There are no user serviceable parts inside this unit. Do not attempt any repairs yourself, doing so will void your manufacturer's warranty. In the unlikely event your unit may require service, please contact ADJ Products, LLC.

*During operation the housing may become extremely hot. Avoid touching the unit with bare hands while in use.*

*ADJ Products, LLC will not accept any liability for any resulting damages caused by the non-observance of this manual or any unauthorized modification to this unit.*

***For Your Own Personal Safety, Please Read and Understand This Manual Completely Before You Attempt To Install Or Operate This Unit!***

- To reduce the risk of electrical shock or fire, do not expose this unit rain or moisture.
- Do not spill water or other liquids into or on to your unit.
- Be sure that the local power outlet match that of the required voltage for your unit.
- Do not attempt to operate this unit if the power cord has been frayed or broken.
- Do not attempt to remove or break off the ground prong from the electrical cord. This prong is used to reduce the risk of electrical shock and fire in case of an internal short.
- Disconnect from main power before making any type of connection.
- Do not remove the cover under any conditions. There are no user serviceable parts inside.
- Never operate this unit when its cover is removed.
- Always be sure to mount this unit in an area that will allow proper ventilation. Allow about 6" (15cm) between this device and a wall.
- Do not attempt to operate this unit if it has been damaged.
- This unit is intended for indoor use only. Use of this product outdoors voids all warranties.
- Always mount this unit in safe and stable matter.
- Power-supply cords should be routed so that they are not likely to be walked on or pinched by items placed upon or against them, paying particular attention to cords at plugs, convenience receptacles, and the point where they exit from the appliance.
- **Cleaning** - The fixture should be cleaned only as recommended by the manufacturer. See the **Cleaning** section of this manual for details.
- **Heat** - This fixture should be situated away from heat sources such as radiators, heat registers, stoves, or other appliances (including amplifiers) that produce heat.
- The fixture should be serviced by qualified service personnel when:
  - A. Objects have fallen, or liquid has been spilled into the appliance.
  - B. The appliance has been exposed to rain or water.
  - C. The appliance does not appear to operate normally, or exhibits a marked change in performance.

**Power Supply:** The ADJ Par ZP100 3K contains an automatic voltage switch, which will auto sense the voltage when it is plugged into the power source. With this switch there is no need to worry about the correct power voltage, this unit can be plugged in anywhere.

**DMX-512:** DMX is short for Digital Multiplex. This is a universal protocol used by most lighting and controller manufacturers as a form of communication between intelligent fixtures and controllers. A DMX controller sends DMX data instructions from the controller to the fixture. DMX data is sent as serial data that travels from fixture to fixture via the DATA “IN” and DATA “OUT” XLR terminals located on all DMX fixtures (most controllers only have a DATA “OUT” terminal).

**DMX Linking:** DMX is a language allowing all makes and models of different manufactures to be linked together and operate from a single controller, as long as all fixtures and the controller are DMX compliant. *To ensure proper DMX data transmission, when using several DMX fixtures try to use the shortest cable path possible. The order in which fixtures are connected in a DMX line does not influence the DMX addressing. For example; a fixture assigned a DMX address of 1 may be placed anywhere in a DMX line, at the beginning, at the end, or anywhere in the middle. When a fixture is assigned a DMX address of 1, the DMX controller knows to send DATA assigned to address 1 to that unit, no matter where it is located in the DMX chain.*

**Data Cable (DMX Cable) Requirements:** The Par ZP100 3K can be controlled via DMX-512 protocol. The Par ZP100 3K has four DMX channel modes; 1 channel mode, 2 channel mode, 3 channel mode, & 4 channel mode. The DMX address is set electronically using the controls on the rear panel of the unit. Your unit and your DMX controller require an approved DMX-512 110 Ohm Data cable for data input and data output (Figure 1). We recommend Accu-Cable DMX cables. If you are making your own cables, be sure to use standard 110-120 Ohm shielded cable (This cable may be purchased at almost all professional sound and lighting stores). Your cables should be made with a male and female XLR connector on either end of the cable. Also remember that DMX cable must be daisy chained and cannot be split.



Figure 1

**Notice:** Be sure to follow figures two and three when making your own cables. Do not use the ground lug on the XLR connector. Do not connect the cable’s shield conductor to the ground lug or allow the shield conductor to come in contact with the XLR’s outer casing. Grounding the shield could cause a short circuit and erratic behavior.

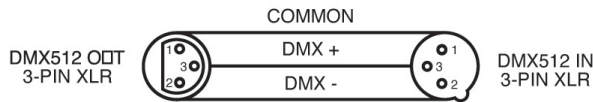

Figure 2

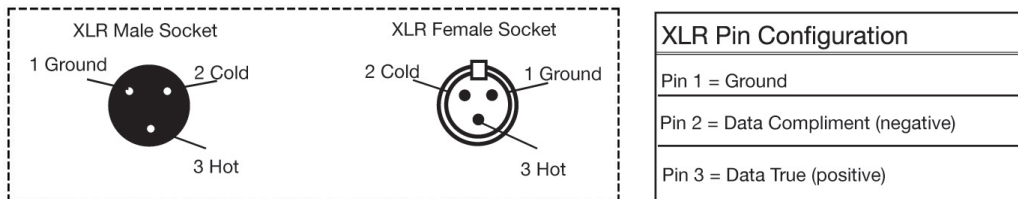

Figure 3

**Special Note: Line Termination.** When longer runs of cable are used, you may need to use a terminator on the last unit to avoid erratic behavior. A terminator is a 110-120 ohm 1/4 watt resistor which is connected between pins 2 and 3 of a male XLR connector (DATA+ and DATA-). This unit is inserted in the female XLR connector of the last unit in your daisy chain to terminate the line. Using a cable terminator (ADJ part number **Z-DMX/T**) will decrease the chances of erratic behavior.



Termination reduces signal errors and avoids signal transmission problems and interference. It is always advisable to connect a DMX terminal, (Resistance 120 Ohm 1/4 W) between PIN 2 (DMX-) and PIN 3 (DMX +) of the last fixture.

Figure 4

**5-Pin XLR DMX Connectors.** This unit use 5-pin DMX-512 data cables for DATA transmission. 5-pin DMX fixtures may be implemented in a 3-pin DMX line. When inserting standard 5-pin data cables in to a 3-pin line, a cable adaptor must be used. These adaptors are readily available at most electronics stores. The chart below details a proper cable conversion.

3-Pin XLR to 5-Pin XLR Conversion		
Conductor	3-Pin XLR Female (Out)	5-Pin XLR Male (In)
Ground/Shield	Pin 1	Pin 1
Data Compliment (- signal)	Pin 2	Pin 2
Data True (+ signal)	Pin 3	Pin 3
Not Used		Pin 4 - Do Not Use
Not Used		Pin 5 - Do Not Use

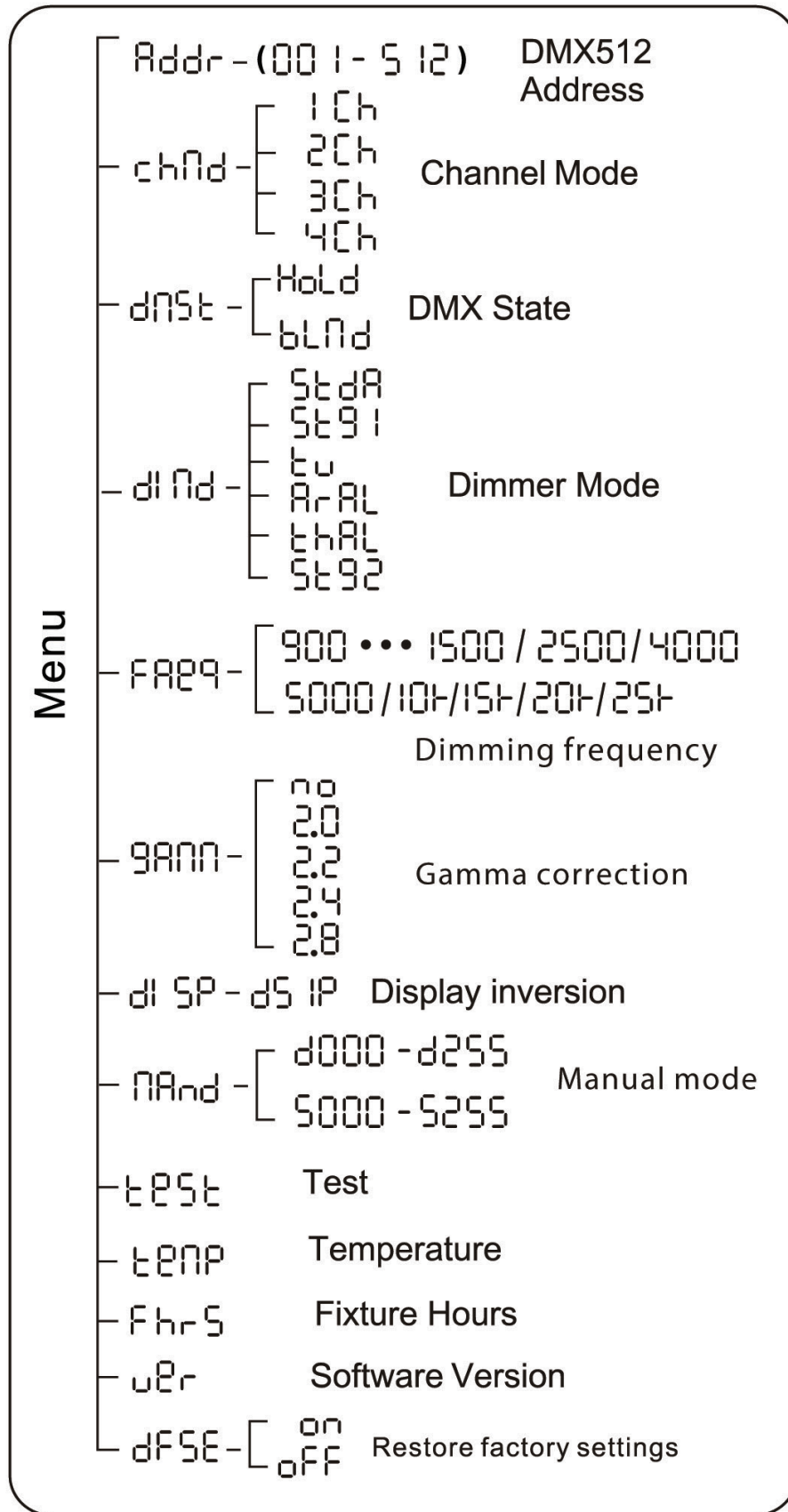



**System Menu:** When making adjustments press ENTER to confirm your setup then press and hold the MENU button for at least 3 seconds. To exit without making any adjustments press the MENU button. The display will lock after 30 seconds, press the MENU button for 3 seconds to unlock.

**Addr - DMX Address Setting.**

1. Press the either the MENU, UP, or DOWN buttons until “Addr” is displayed. Press ENTER.
2. The current address will now be displayed and flashing. Press the UP or DOWN buttons to find your desired address. Press ENTER to set your desired DMX address.

**Chnd - This will let you select your desired DMX channel mode.**

1. Press the either the MENU button until “Chnd” is displayed, press ENTER. The current DMX channel mode will be displayed.
2. Press the UP or DOWN buttons to find your desired DMX channel mode and press ENTER to confirm and exit.

**dnSt - This setting defines the behavior of the fixture in the event that the DMX signal is lost, interrupted, or power is lost.**

1. Press the MENU button until “dnSt” is displayed, and either “BLND or “LAST” will be displayed beneath.
2. Press ENTER and the bottom choice will begin to flash. Use the UP or DOWN buttons to choose an operating mode you would like the unit to start up in when power is applied or the DMX signal is lost.
  - *BLND (Blackout)* - If the DMX signal is lost or interrupted, the unit will automatically go into stand by mode.
  - *HOLD* - If the DMX signal is lost the fixture will stay in the last DMX setting. If power is applied and this mode is set, the unit will automatically go into the last DMX set up.
3. Press ENTER to confirm your desired set up.

**dInd - This will let select your desired dimmer curve.**

1. Press the MENU button until “dInd” is displayed, and press ENTER. 1 of 6 dimmer curves will be displayed. See the ***Dimmer Curve Chart*** section of this manual for details.
  - “STDA” (standard)
  - “STGE” (stage)
  - “TV” (TV)
  - “ARAL” (Architectural)
  - “THAL” (Theatre)
  - (Stage 2)
2. Press the UP or DOWN buttons to find your desired dimmer curve and press ENTER to confirm and exit.

**FReq - With this function you can adjust the dimming frequency.**

1. Press the MENU button until “FReq” is displayed, then press ENTER.
2. Use the UP or DOWN buttons to adjust the dimming frequency between 900hz, 1000hz, 1100hz, 1200hz, 1300hz, 1400hz, 1500hz, 2500hz, 4000hz, 5000hz, 10000hz, 15000hz, 20000hz, or 250000hz.
3. Once you have found your desired dimming frequency press ENTER to confirm.

**gAnn - In this menu you are able to make gamma corrections.**

1. Press the MENU button until “gAnn” is displayed, then press ENTER.
2. Use the UP or DOWN buttons to scroll through gamma correction options.
3. Once you have found your desired gamma correction press ENTER to confirm.

**dISP - This function will invert the display 180 degrees.**

1. Press the MENU button until “dISP” is displayed, then press ENTER.
2. Press the UP button to select “dSIP” to “flip” the display, or “dISP” to revert the display to normal.
3. Press ENTER to confirm.

**NAnd - This function will allow you to manually adjust each brightness, fine dimming, and strobing. Fine dimming and strobing are only used with 3 channel mode.**

1. Press the MENU button until “NAnd” is displayed, then press ENTER.
2. Use the UP and DOWN buttons to scroll through the settings. Once you have found your desired function you would like to adjust press ENTER.
3. After you have pressed ENTER, use the UP and DOWN buttons to adjust the values. Once you have made your adjustments press ENTER to set them. Press the MENU button to exit.

**teSt - This function will run a self-test program.**

1. Press the MENU button until “teSt” is displayed, then press ENTER.
2. The fixture will now run a self test. Press the MENU button to exit and quit the self test.

**tENP - With this function you can check the temperature of the fixture.**

1. Press the MENU button until “tENP” is displayed, then press ENTER.
2. The fixture temperature will now be displayed. Press MENU to exit.

**FhrS - With this function you can display the running time of the unit.**

1. Press the MENU button until “FhrS” is displayed, then press ENTER.
2. The running time of the fixture will now be displayed. Press MENU to exit.

**ver - Use this function to display the software version of the unit.**

1. Press the MENU button until “ver” is displayed, then press ENTER.
2. The display will now show the software version.

**Universal DMX Control:** This function allows you to use a universal DMX-512 controller to control the dimmer, fine dimmer and strobe. A DMX controller allows you to create unique programs tailored to your individual needs.

1. The Par ZP100 3K has 4 DMX channel modes; 1 channel mode, 2 channel mode, 3 channel mode, 4 channel mode. See the **Channel Mode** sections of this manual for detailed descriptions of the DMX values and traits.
2. To control your fixture in DMX mode, follow the set-up procedures in the **DMX Set Up** section of this manual, as well as the set-up specifications that are included with your DMX controller.
3. Use the controller's faders to control the various DMX fixture traits.
4. This will allow you to create your own programs.
5. Follow the instructions shown in the **System Menu** section of this manual to select your DMX channel mode and set your desired DMX address.
6. For longer cable runs (more than a 100 feet) use a terminator on the last fixture.
7. For help operating in DMX mode consult the manual included with your DMX controller.

To adjust the beam angle slide the beam angle adjuster located inside/in front of the lens. See diagram below.

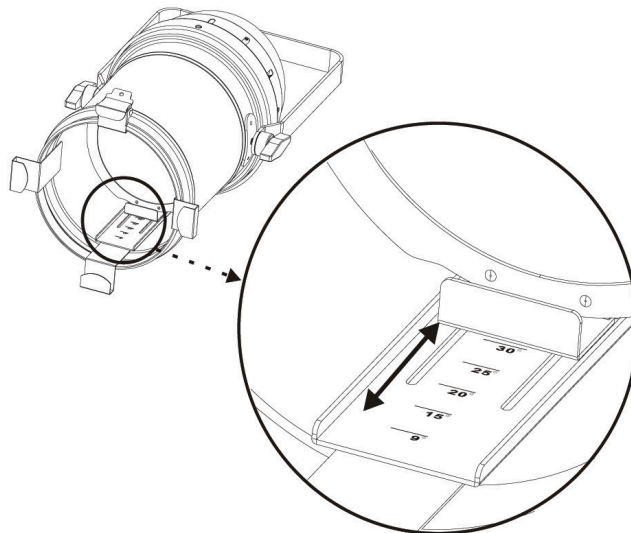

The beam angle can be adjusted manually, between 9°/ 15°/ 20°/25°/ 30°.

Channel	Value	Function
1	0 - 255	DIMMER 0% - 100%

Channel	Value	Function
1	0 - 255	DIMMER 0% - 100%
2	0 - 31	SHUTTER/STROBE LED OFF
	32 - 63	LED ON
	64 - 95	STROBING SLOW - FAST
	96 - 127	LED ON
	128 - 159	PULSE EFFECT
	160 - 191	LED ON
	192 - 223	RANDOM STROBE SLOW - FAST
	224 - 255	LED ON

Channel	Value	Function
1	0 - 255	DIMMER 0% - 100%
2	0 - 255	DIMMING FINENESS
3	0 - 31	SHUTTER/STROBE LED OFF
	32 - 63	LED ON
	64 - 95	STROBING SLOW - FAST
	96 - 127	LED ON
	128 - 159	PULSE EFFECT
	160 - 191	LED ON
	192 - 223	RANDOM STROBE SLOW - FAST
	224 - 255	LED ON

Channel	Value	Function
1	0 - 255	DIMMER 0% - 100%
2	0 - 255	DIMMING FINENESS
3	0 - 31 32 - 63 64 - 95 96 - 127 128 - 159 160 - 191 192 - 223 224 - 255	SHUTTER/STROBE LED OFF LED ON STROBING SLOW - FAST LED ON PULSE EFFECT LED ON RANDOM STROBE SLOW - FAST LED ON
4	0 - 20 21 - 40 41 - 60 61 - 80 81 - 100 101 - 120 121 - 255	DIMMER MODE STANDARD STAGE TV ARCHITECTURAL THEATRE STAGE 2 DEFAULT DIMMER SETTING

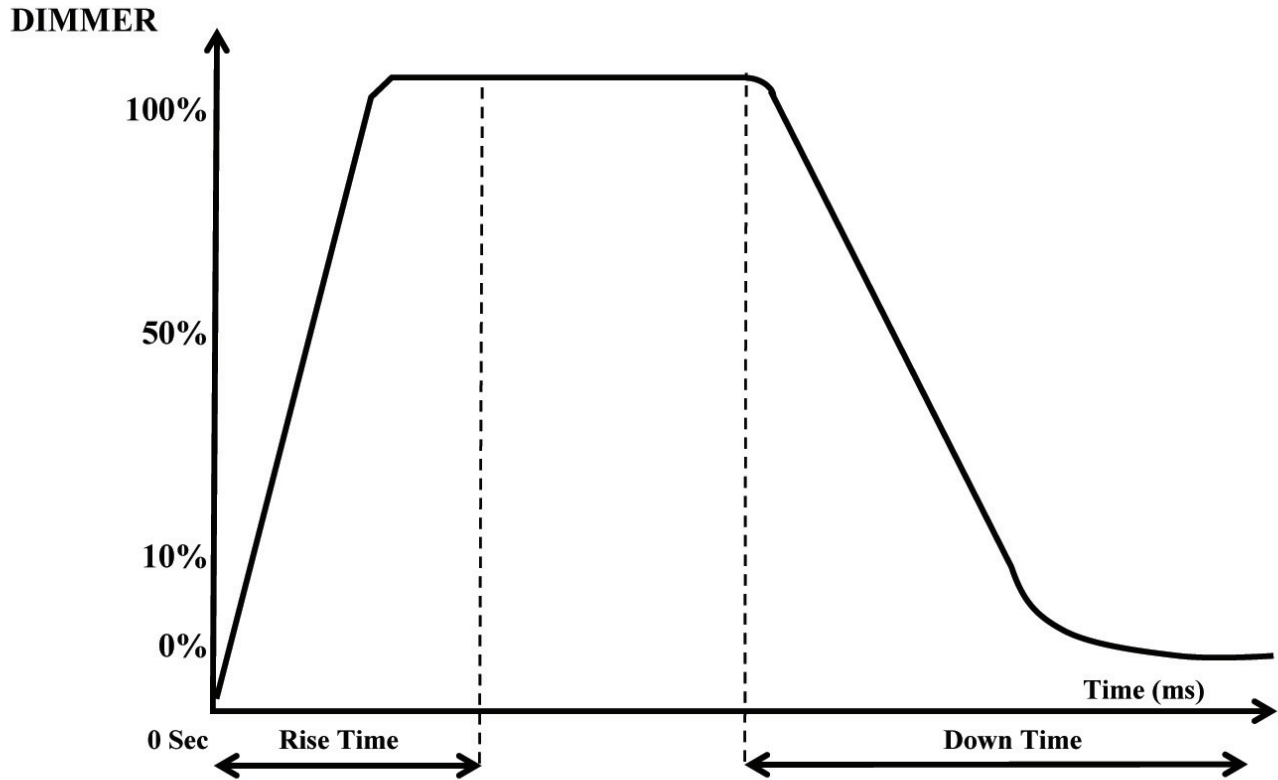

Dimming Curve Ramp Effect	0 sec Fade Time		1 sec Fade Time	
	Rise Time (ms)	Down Time (ms)	Rise Time (ms)	Down Time (ms)
Standard (default)	0	0	0	0
Stage	780	1100	1540	1660
TV	1180	1520	1860	1940
Architectural	1380	1730	2040	2120
Theatre	1580	1940	2230	2280
Stage 2	0	1100	0	1660

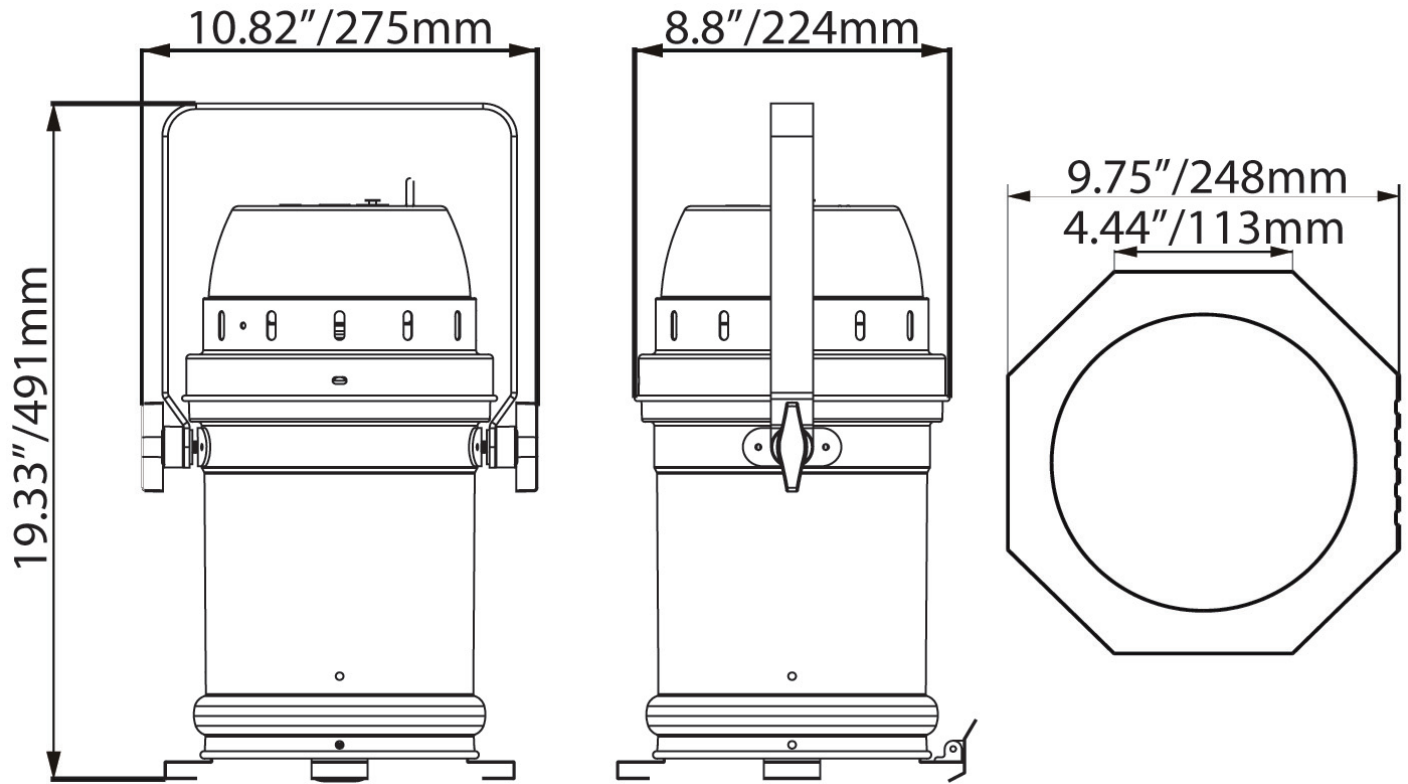



The unit should be mounted using a mounting clamp (not provided), affixing it to the mounting bracket that is provided with the unit. Always ensure that the unit is firmly fixed to avoid vibration and slipping while operating. Always ensure that the structure to which you are attaching the unit is secure and is able to support at least 10 times the unit's weight. Also, always use a safety cable that can hold 12 times the weight of the unit when installing the fixture.

The equipment must be installed by a professional, and it must be installed in a place where it is out of the reach of people's grasp.

With this feature you can connect the fixtures to one another using the power input and output sockets. The quantity that can be connected is as follows:

*15 fixtures maximum @ 120V*

*25 fixtures maximum @ 230V*

After these values are exceeded, additional power outlets will be needed to accommodate additional devices.

***NOTE: USE CAUTION WHEN POWER LINKING OTHER FIXTURES TO THE Par ZP100 3K AS THE POWER CONSUMPTION OF OTHER LIGHTING FIXTURES WILL VARY!***

Unplug the unit from any power source it may be connected to. Once the power has been disconnected, use a phillips head screw driver to unscrew the fuse holder located above the power input. Remove the bad fuse and replace with a new one, and screw the fuse holder back in.

Due to the effects of fog residue, smoke, and dust, cleaning the internal and external optical lenses and mirror should be carried out periodically to optimize light output. Cleaning frequency depends on the environment in which the fixture operates (I.e. smoke, fog residue, dust, dew). In heavy club use, cleaning on a monthly basis is recommended. Periodic cleaning will ensure longevity and crisp output.

1. Use normal glass cleaner and a soft cloth to wipe down the outside casing.
2. Use a brush to wipe down the cooling vents and fan grill.
3. Clean the external optics with glass cleaner and a soft cloth every 20 days.
4. Clean the internal optics with glass cleaner and a soft cloth every 30-60 days.
5. Always be sure to dry all parts completely before plugging the unit back in.

**Trouble Shooting:** Listed below are a few common problems that you may encounter, with possible solutions.

***No light output from the unit;***

1. Be sure the external fuse has not blown. The fuse is located on the rear panel of the unit.
2. Be sure the fuse holder is completely and properly seated.



**MANUFACTURER'S LIMITED WARRANTY**

- A. ADJ Products, LLC hereby warrants, to the original purchaser, ADJ Products, LLC products to be free of manufacturing defects in material and workmanship for a prescribed period from the date of purchase (see specific warranty period on reverse). This warranty shall be valid only if the product is purchased within the United States of America, including possessions and territories. It is the owner's responsibility to establish the date and place of purchase by acceptable evidence, at the time service is sought.
- B. For warranty service you must obtain a Return Authorization number (RA#) before sending back the product—please contact ADJ Products, LLC Service Department at 800-322-6337. Send the product only to the ADJ Products, LLC factory. All shipping charges must be pre-paid. If the requested repairs or service (including parts replacement) are within the terms of this warranty, ADJ Products, LLC will pay return shipping charges only to a designated point within the United States. If the entire instrument is sent, it must be shipped in its original package. No accessories should be shipped with the product. If any accessories are shipped with the product, ADJ Products, LLC shall have no liability whatsoever for loss of or damage to any such accessories, nor for the safe return thereof.
- C. This warranty is void if the serial number has been altered or removed; if the product is modified in any manner which ADJ Products, LLC concludes, after inspection, affects the reliability of the product; if the product has been repaired or serviced by anyone other than the ADJ Products, LLC factory unless prior written authorization was issued to purchaser by ADJ Products, LLC; if the product is damaged because not properly maintained as set forth in the instruction manual.
- D. This is not a service contract, and this warranty does not include maintenance, cleaning or periodic check up. During the period specified above, ADJ Products, LLC will replace defective parts at its expense with new or refurbished parts, and will absorb all expenses for warranty service and repair labor by reason of defects in material or workmanship. The sole responsibility of ADJ Products, LLC under this warranty shall be limited to the repair of the product, or replacement thereof, including parts, at the sole discretion of ADJ Products, LLC. All products covered by this warranty were manufactured after August 15, 2012, and bear identifying marks to that effect.
- E. ADJ Products, LLC reserves the right to make changes in design and/or improvements upon its products without any obligation to include these changes in any products theretofore manufactured.
- F. No warranty, whether expressed or implied, is given or made with respect to any accessory supplied with products described above. Except to the extent prohibited by applicable law, all implied warranties made by ADJ Products, LLC in connection with this product, including warranties of merchantability or fitness, are limited in duration to the warranty period set forth above. And no warranties, whether expressed or implied, including warranties of merchantability or fitness, shall apply to this product after said period has expired. The consumer's and/or Dealer's sole remedy shall be such repair or replacement as is expressly provided above; and under no circumstances shall ADJ Products, LLC be liable for any loss or damage, direct or consequential, arising out of the use of, or inability to use, this product.

This warranty is the only written warranty applicable to ADJ Products, LLC Products and supersedes all prior warranties and written descriptions of warranty terms and conditions heretofore published.

**MANUFACTURER'S LIMITED WARRANTY PERIODS**

- **Lighting Products = 1-year (365 days) Limited Warranty** (Such as: Special Effect Lighting, Intelligent Lighting, UV lighting, Strobes, Fog Machines, Bubble Machines, Mirror Balls, Par Cans, Trussing, Lighting Stands etc. excluding LED and lamps)
- **Laser Products = 1 Year (365 Days) Limited Warranty** (excluding laser diodes which have a 6 month limited warranty)
- **L.E.D. Products = 2-year (730 days) Limited Warranty** (excluding motors, PCB boards, and power supplies, which have a 1-year (365 day Limited Warranty) batteries which have a 180 day limited warranty). Only the L.E.D.s carry a 2-year warranty (**excluding StarTec Series which carries a 1 Year Limited Warranty**)
- **ADJ DMX Controllers = 2 Year (730 Days) Limited Warranty**

<b>Model:</b>	<b>Par ZP100 3K</b>
<b>Voltage:</b>	100 - 240V, 50/60 Hz
<b>LED:</b>	1 x 98W COB LED
<b>Power Consumption:</b>	115W
<b>Power Linking:</b>	15 Fixtures Max @ 120V 25 Fixtures Max @ 230V
<b>Dimensions:</b>	19.33" (L) x 10.82" (W) x 8.75" (H) 491 x 275 x 224 mm (with Bracket)
<b>Weight:</b>	8 Lbs. / 3.6 kgs
<b>Beam Angle:</b>	9/15/20/25/30 Degrees
<b>Fuse:</b>	3.15 Amp
<b>Duty Cycle:</b>	None
<b>DMX:</b>	4 Channel Modes: 1/2/3/4
<b>Control:</b>	RDM (Remote Device Management)
<b>Color Temperature:</b>	3000K
<b>Working Position:</b>	Any Safe, Secure Position
<b>Warranty:</b>	2 Year (730 days)

**Please Note:** Specifications and improvements in the design of this unit and this manual are subject to change without any prior written notice.

**Auto Sensing Voltage:** This fixture contains an automatic voltage switch, which will automatically

ADJ Products, LLC  
6122 S. Eastern Ave. Los Angeles, CA 90040 USA  
Tel: 323-582-2650 / Fax: 323-582-2941  
[www.adj.com](http://www.adj.com) / [info@adj.com](mailto:info@adj.com)

Follow Us On:



[facebook.com/americanadj](https://facebook.com/americanadj)  
[twitter.com/americanadj](https://twitter.com/americanadj)  
[youtube.com/adjlighting](https://youtube.com/adjlighting)

A.D.J. Supply Europe B.V.  
Junostraat 2  
6468 EW Kerkrade  
Netherlands

[www.adj.eu](http://www.adj.eu) / [support@adjgroup.eu](mailto:support@adjgroup.eu)  
Tel: +31 45 546 85 00 / Fax: +31 45 546 85 99

