

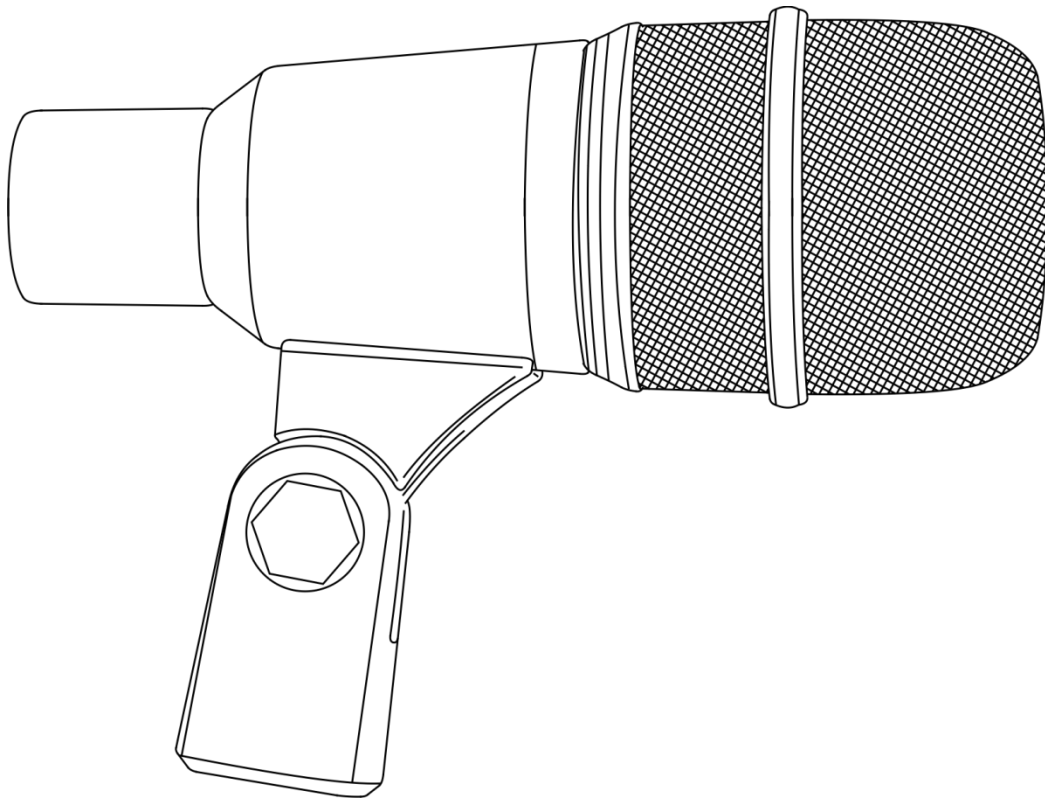

# MANUAL



ENGLISH

**DM-25**

**V1**

Ordercode: D1333

## Table of contents

---

<b>Warning</b> .....	2
Safety Instructions.....	2
Operating Determinations.....	3
Connection with the mains .....	3
Return Procedure .....	4
Claims .....	4
<b>Description of the device</b> .....	5
Overview .....	Fout! Bladwijzer niet gedefinieerd.
<b>Installation</b> .....	5
<b>Set Up and Operation</b> .....	6
Setup Example.....	6
Frequency.....	6
<b>Connection Cables</b> .....	7
Compensation of Interference With Balanced Connections .....	8
<b>Maintenance</b> .....	8
<b>Troubleshooting</b> .....	8
<b>Product Specifications</b> .....	9

## Warning



**For your own safety, please read this user manual carefully  
before your initial start-up!**



### Unpacking Instructions

Immediately upon receiving this product, carefully unpack the carton and check the contents to ensure that all parts are present, and have been received in good condition. Notify the dealer immediately and retain packing material for inspection if any parts appear damaged from shipping or the carton itself shows signs of mishandling. Save the carton and all packing materials. In the event that a device must be returned to the factory, it is important that the device is returned in the original factory box and packing.

### Your shipment includes:

- DAP Audio DM-25
- DM-25 case
- User manual

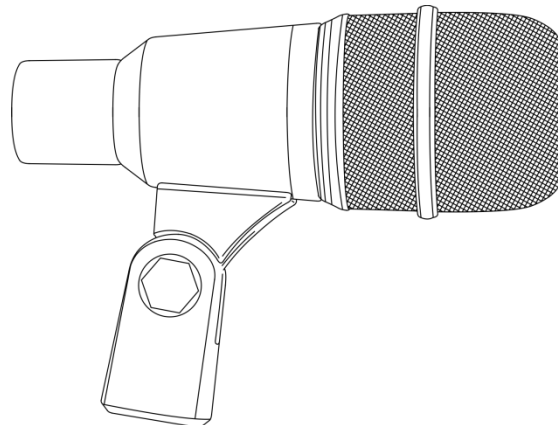

**CAUTION!**  
**Keep this device away from rain and moisture!**  
**Unplug mains lead before opening the housing!**



### Safety Instructions

Every person involved with the installation, operation and maintenance of this system has to:

- be qualified
- follow the instructions of this manual



**CAUTION! Be careful with your operations.**  
**With a dangerous voltage you can suffer  
a dangerous electric shock when touching the wires!**



Before the initial start-up, please make sure that there is no damage caused by transportation. Should there be any, consult your dealer and do not use the system.

To maintain perfect condition and to ensure a safe operation, it is absolutely necessary for the user to follow the safety instructions and warning notes written in this manual.

Please consider that damages caused by manual modifications to the system are not subject to warranty.

This system contains no user-serviceable parts. Refer servicing to qualified technicians only.

**IMPORTANT:**

The manufacturer will not accept liability for any resulting damages caused by the non-observance of this manual or any unauthorized modification to the device.

- Never remove warning or informative labels from the unit.
- Never leave any cables lying around.
- Do not open the device and do not modify the device.
- Do not connect this device to a dimmerpack.
- Do not switch the system on and off in short intervals, as this would reduce the system's life.
- Only use device indoors, avoid contact with water or other liquids.
- Avoid flames and do not put close to flammable liquids or gases.
- Always disconnect power from the mains, when device is not used or before cleaning! Only handle the power cord by the plug. Never pull out the plug by tugging the power cord.
- Make sure you do not use the wrong kind of cables or defective cables.
- Make sure that the power cord is never crimped or damaged. Check the system and the power cord from time to time.
- If system is dropped or struck, disconnect the power supply immediately. Have a qualified engineer inspect for safety before operating.
- If the system has been exposed to drastic temperature fluctuation (e.g. after transportation), do not switch it on immediately. The arising condensation water might damage your system. Leave the system switched off until it has reached room temperature.
- If your Dap Audio device fails to work properly, discontinue use immediately. Pack the unit securely (preferably in the original packing material), and return it to your Dap Audio dealer for service.
- Repairs, servicing and electric connection must be carried out by a qualified technician.
- WARRANTY: Till one year after date of purchase.

**Operating Determinations**

- This device is not designed for permanent operation. Consistent operation breaks will ensure that the device will serve you for a long time without defects.
- The maximum ambient temperature  $t_a = 40^\circ\text{C}$  must never be exceeded.
- The relative humidity must not exceed 50 % with an ambient temperature of  $40^\circ\text{C}$ .
- If this device is operated in any other way, than the one described in this manual, the product may suffer damages and the warranty becomes void.
- Any other operation may lead to dangers like short-circuit, burns, electric shock, crash, etc.

*You endanger your own safety and the safety of others!*

**Connection with the mains**

Connect the device to the mains with the power-plug.

Always pay attention, that the right color cable is connected to the right place.

International	EU Cable	UK Cable	US Cable	Pin
L	BROWN	RED	YELLOW/COPPER	PHASE
N	BLUE	BLACK	SILVER	NEUTRAL
	YELLOW/GREEN	GREEN	GREEN	PROTECTIVE GROUND

*Make sure that the device is always connected properly to the earth!*

*Improper installation can cause serious damage to people and property!*



## Return Procedure



Returned merchandise must be sent prepaid and in the original packing, call tags will not be issued. Package must be clearly labeled with a Return Authorization Number (RMA number). Products returned without an RMA number will be refused. Highlite will not accept the returned goods or any responsibility. Call Highlite 0031-455667723 or mail [aftersales@highlite.nl](mailto:aftersales@highlite.nl) and request an RMA prior to shipping the fixture. Be prepared to provide the model number, serial number and a brief description of the cause for the return. Be sure to properly pack fixture, any shipping damage resulting from inadequate packaging is the customer's responsibility. Highlite reserves the right to use its own discretion to repair or replace product(s). As a suggestion, proper UPS packing or double-boxing is always a safe method to use.

**Note: If you are given an RMA number, please include the following information on a piece of paper inside the box:**

- 01) Your name
- 02) Your address
- 03) Your phone number
- 04) A brief description of the symptoms

## Claims

The client has the obligation to check the delivered goods immediately upon delivery for any shortcomings and/or visible defects, or perform this check after our announcement that the goods are at their disposal. Damage incurred in shipping is the responsibility of the shipper; therefore the damage must be reported to the carrier upon receipt of merchandise.

It is the customer's responsibility to notify and submit claims with the shipper in the event that a fixture is damaged due to shipping. Transportation damage has to be reported to us within one day after receipt of the delivery.

Any return shipment has to be made post-paid at all times. Return shipments must be accompanied with a letter defining the reason for return shipment. Non-prepaid return shipments will be refused, unless otherwise agreed in writing.

Complaints against us must be made known in writing or by fax within 10 working days after receipt of the invoice. After this period complaints will not be handled anymore.

Complaints will only then be considered if the client has so far complied with all parts of the agreement, regardless of the agreement of which the obligation is resulting.

## Description of the device

The dynamic cartridge of the DAP Audio DM-25 with a cardioid polar pattern is tuned specifically for close miking of snare drums, toms and percussion. It features a bright and neutral reproduction.

### Features

- Type: Dynamic, moving coil
- Frequency response: 50–16000Hz
- Polar pattern: Super Cardioid
- Sensitivity (1000Hz): 2,2 mV/Pa\* (\*1 Pa= 94dB SPL)
- Maximum SPL: 134dB
- THD: ≤ 1% 1000Hz
- Impedance: 500  $\Omega$
- Connections: 1 x 3-pin XLR OUT
- Accessories: Thread adapter 5/8, 4/8, 3/8, integrated stand, storage case
- Dimensions (case): 300 x 120 x 75 mm (LxWxH)
- Dimensions (microphone): 105 x 40 x 85 mm (LxWxH)
- Weight: 0,2 kg

### Optional accessories

D8930 – Microphone drum clamp

D8931 – Microphone drum clamp

### Overview

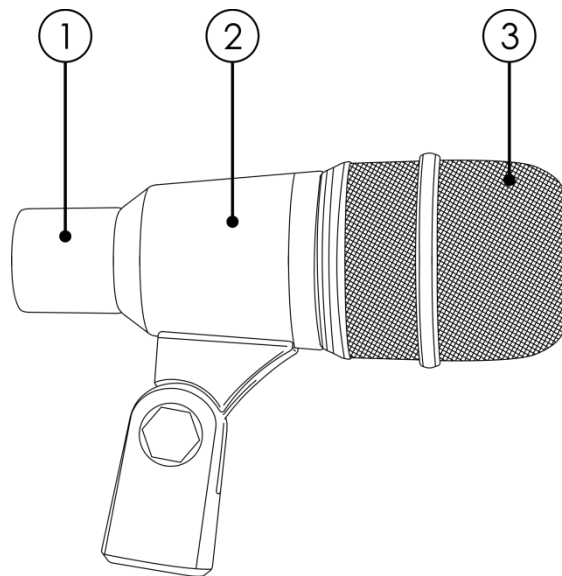

Fig. 01

- ① 3-pin XLR OUT
- ② Body
- ③ Head

## Installation

Remove all packing materials from the DM-25. Check if all foam and plastic padding is removed. Connect all cables.

**Always disconnect from electric mains power supply before cleaning or servicing.**  
**Damages caused by non-observance are not subject to warranty.**

## Set Up and Operation

- 01) Set all volume and gain controls on your mixer, mic preamp or recording device to the minimum before connecting the microphone. **Make sure that the phantom power is off!**
- 02) Once the DM-25 is plugged in, move the channel fader gradually to the 0dB position. Adjust the input gain, using your channel peak LED or the VU-meter.

### Setup Example

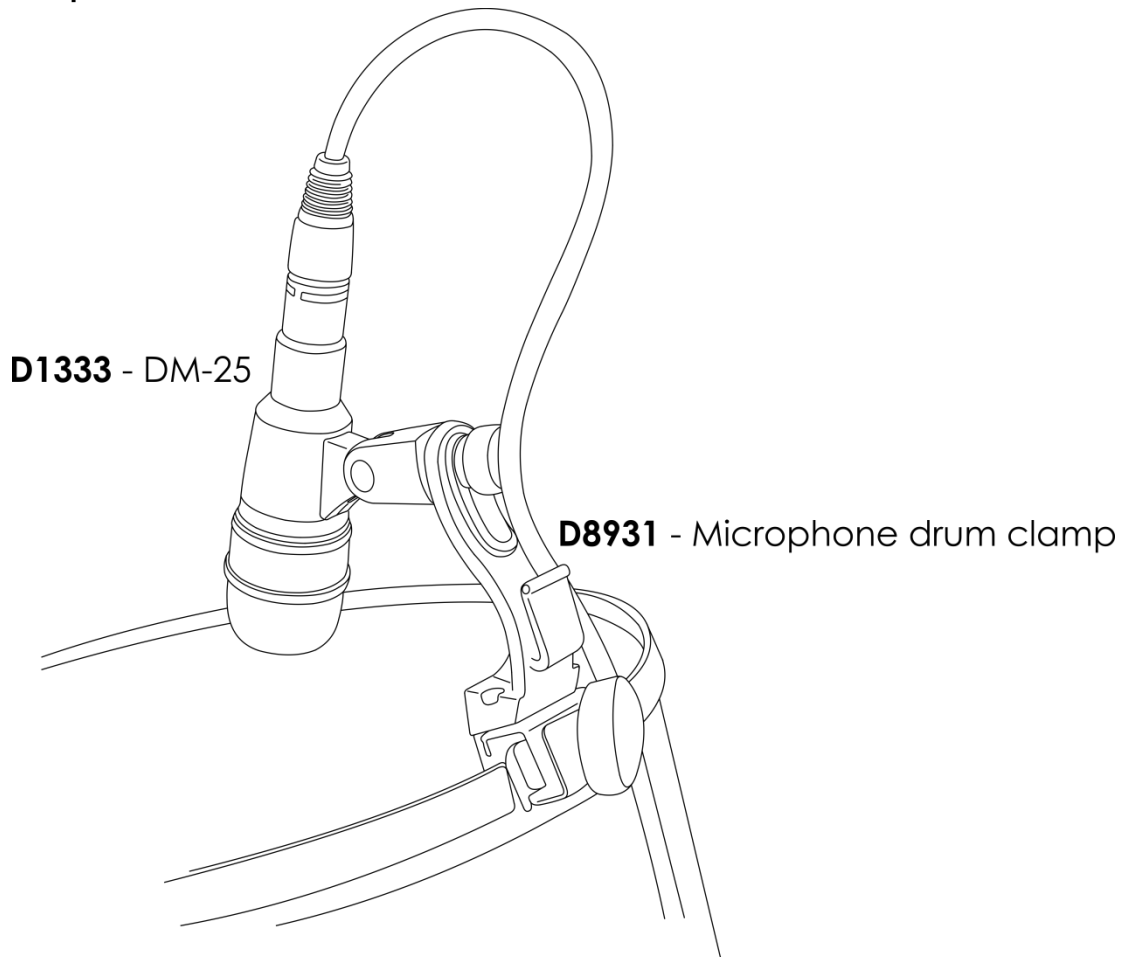

Fig. 02

### Frequency

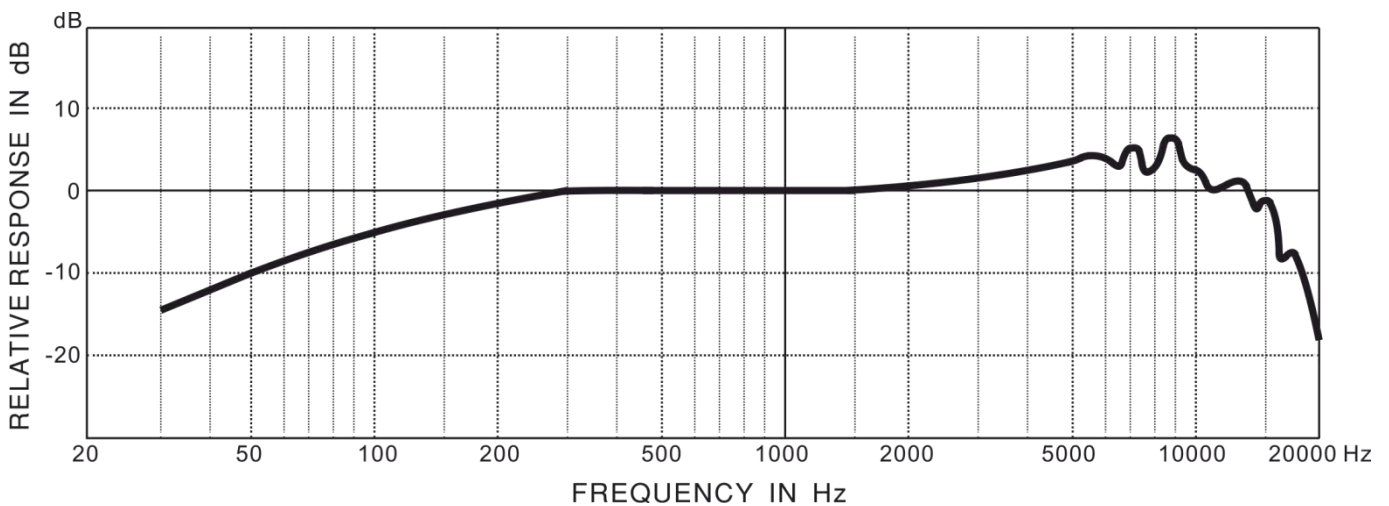
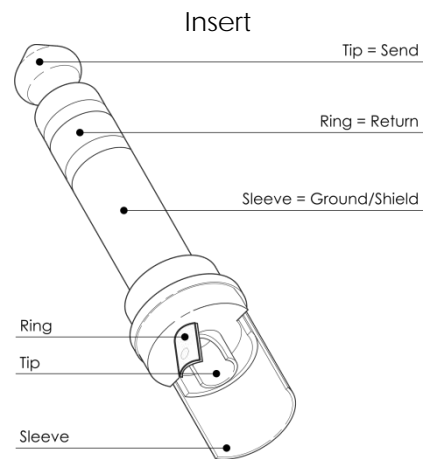
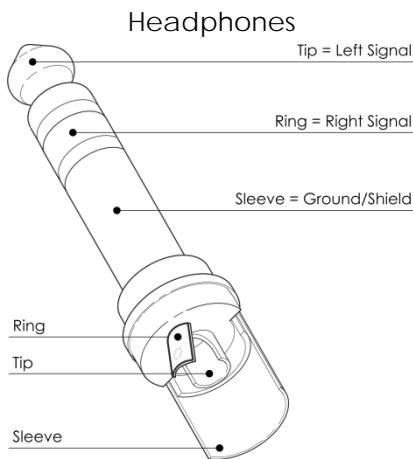
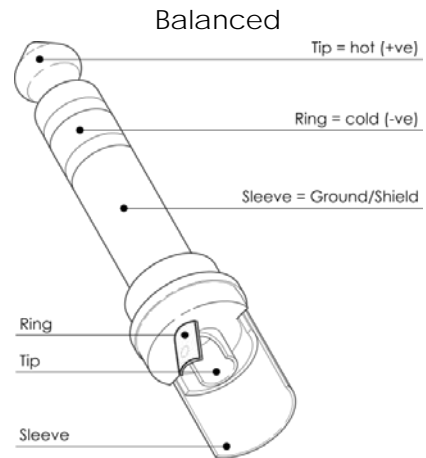
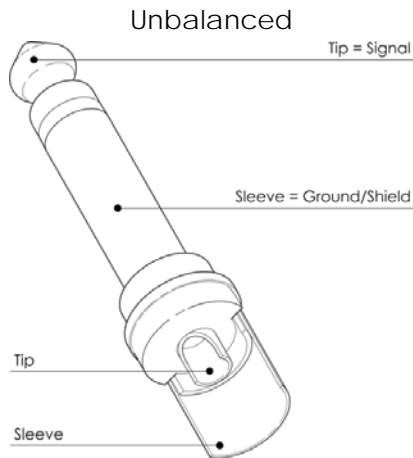

Fig. 03

## Connection Cables

Take care of your cables, always holding them by the connectors and avoiding knots and twists when coiling them: This gives the advantage of increasing their life and reliability. Periodically check your cables. A great number of problems (faulty contacts, ground hum, discharges, etc.) are caused entirely by using unsuitable or faulty cables.



For these applications the unit provides 1/4" TRS and XLR connectors to easily interface with most professional audio devices. Follow the configuration examples below for your particular connection.

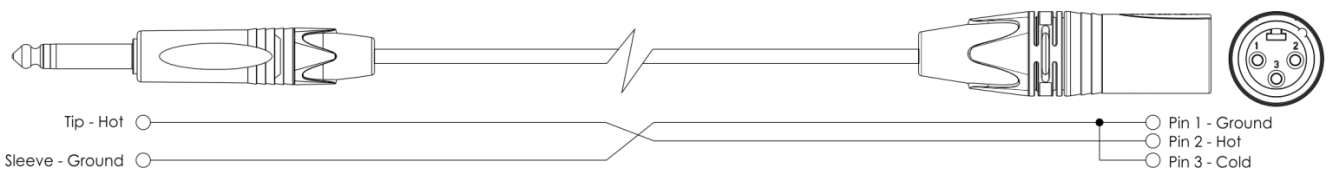
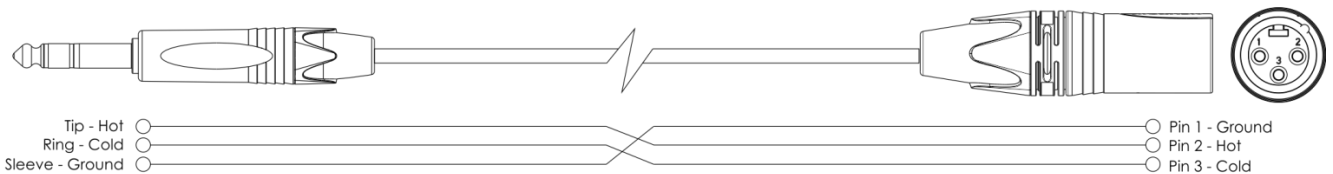
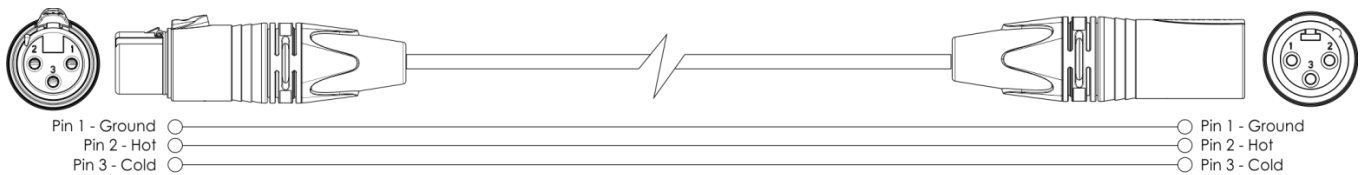



## Compensation of Interference With Balanced Connections

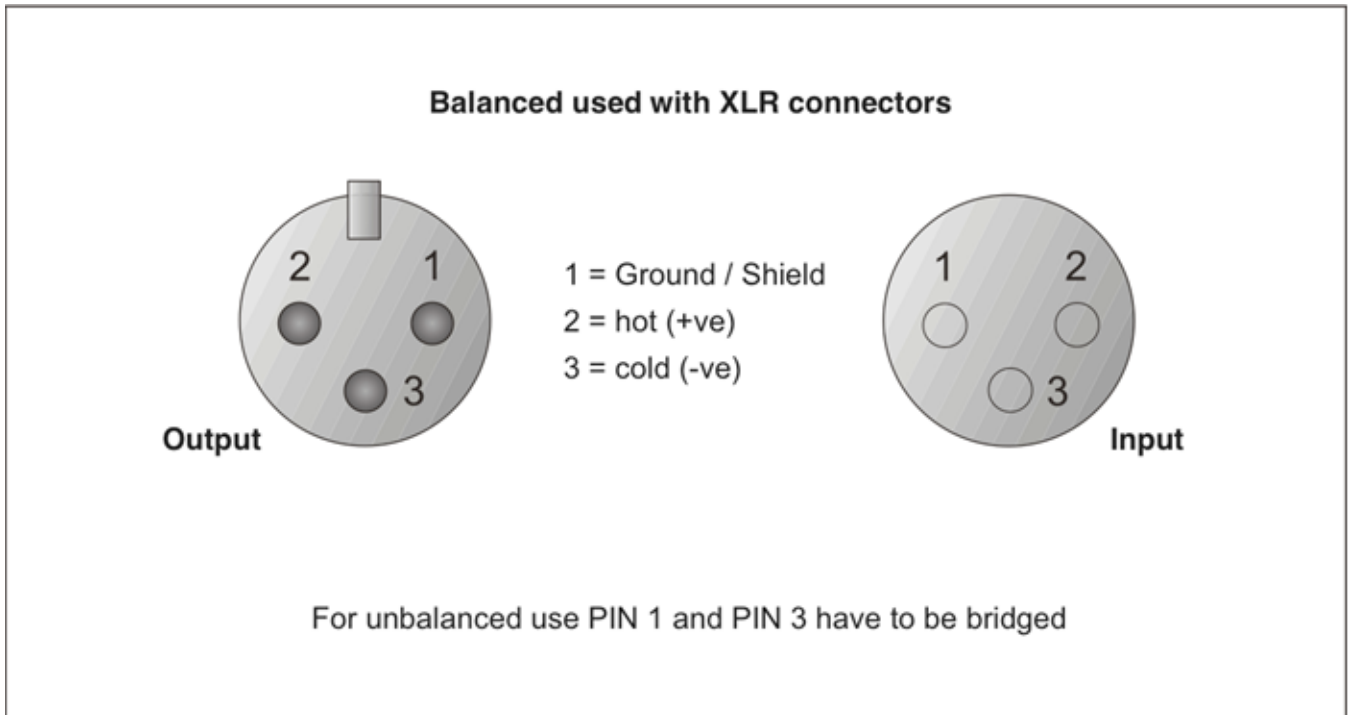

## Maintenance

The DAP Audio DM-25 requires almost no maintenance. However, you should keep the unit clean. Disconnect the mains power supply, and then wipe the cover with a damp cloth. Do not immerse in liquid. Do not use alcohol or solvents.

Keep connections clean. Disconnect electric power, and then wipe the audio connections with a damp cloth. Make sure connections are thoroughly dry before linking equipment or supplying electric power.

## Troubleshooting

DAP Audio DM-25

This troubleshooting guide is meant to help solve simple problems. If a problem occurs, carry out the steps below in sequence until a solution is found. Once the unit operates properly, do not carry out following steps.

- 01) If the device does not operate properly, unplug the device.
- 02) Check power from the wall, all cables, connections, etc.
- 03) If all of the above appears to be O.K., plug the unit in again.
- 04) If nothing happens after 30 seconds, unplug the device.
- 05) Return the device to your DAP Audio dealer.

## Product Specifications

Model:	DAP Audio DM-25
Dimensions (case):	300 x 120 x 75 mm (LxWxH)
Dimensions (microphone):	105 x 40 x 85 mm (LxWxH)
Weight:	0,2 kg
<b>Operating:</b>	
Signal output:	3-pin XLR OUT
<b>Features:</b>	
Type:	Dynamic, moving coil
Frequency response:	50–16000Hz
Polar pattern:	Super Cardioid
Sensitivity (1000Hz):	2,2 mV/Pa* (*1 Pa= 94dB SPL)
Maximum SPL:	134dB
THD:	≤ 1% 1000Hz
Impedance:	500 Ω
Connections:	1 x 3-pin XLR OUT
Accessories:	Thread adapter 5/8, 4/8, 3/8, integrated stand, storage case
Max. ambient temperature $t_a$ :	40°C
Max. housing temperature $t_B$ :	80°C

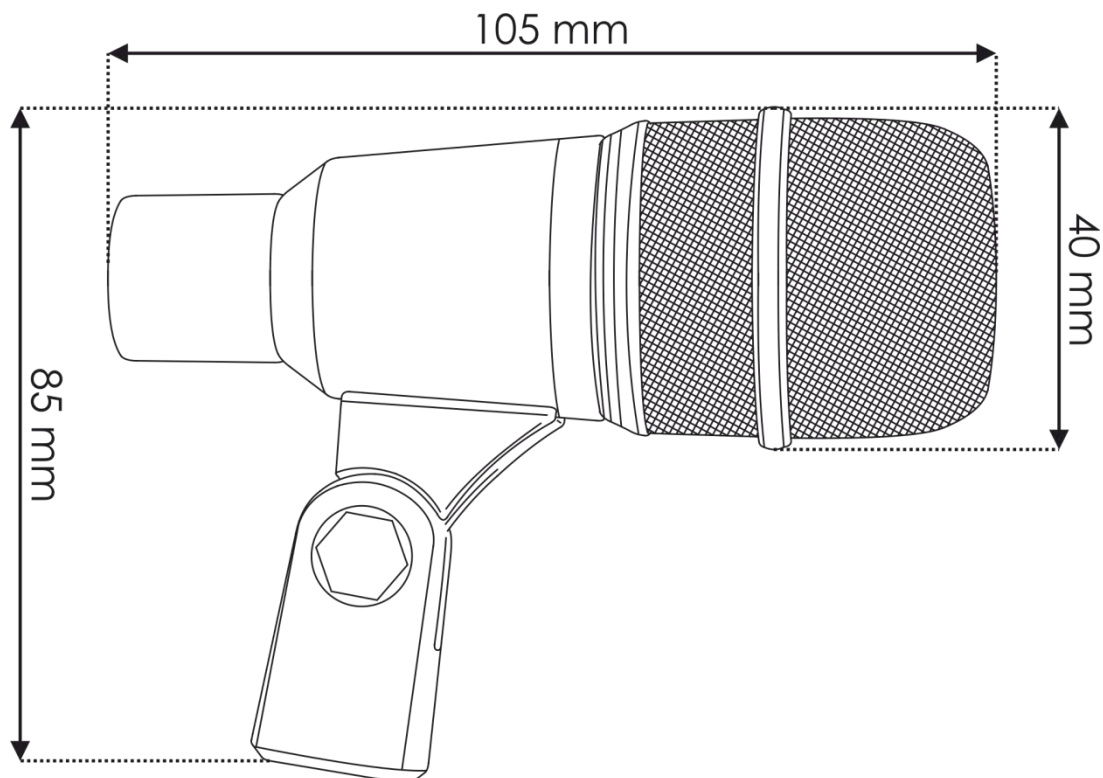

Design and product specifications are subject to change without prior notice.



Website: [www.Dap-audio.info](http://www.Dap-audio.info)  
 Email: [service@highlite.nl](mailto:service@highlite.nl)





©2016 DAP Audio