

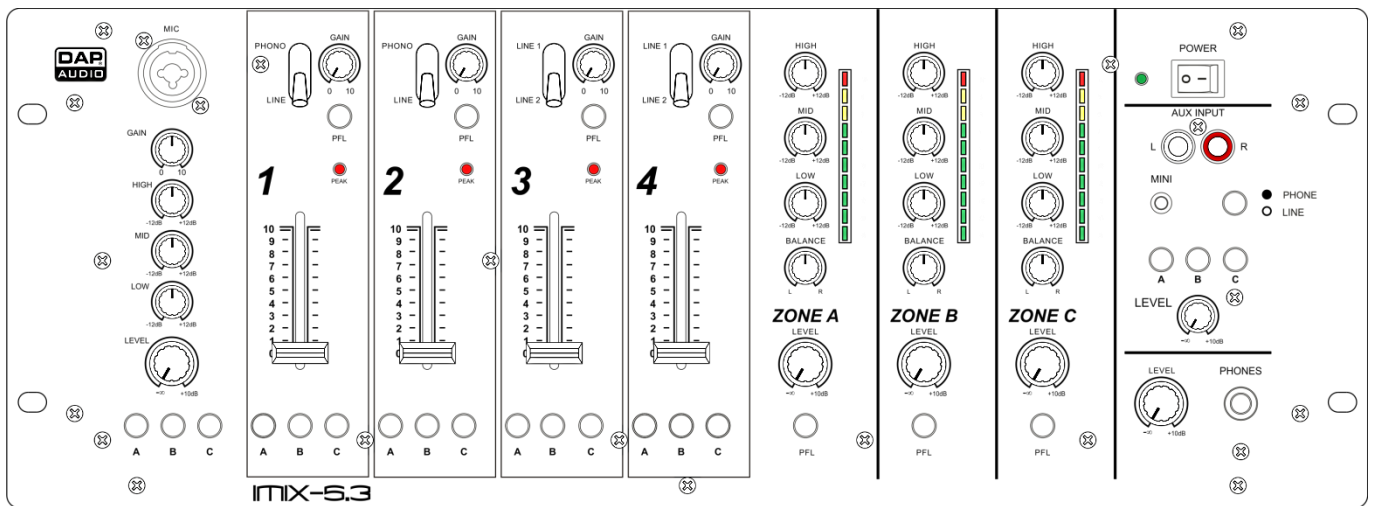

MANUAL



ENGLISH

IMIX 5.3
Ordercode: D2352

Table of contents

Warning	2
Unpacking Instructions.....	2
Safety Instructions	2
Operating Determinations	3
Connection with the mains.....	4
Return Procedure.....	4
Claims.....	4
Description of the device	4
Features	4
Overview	5
Front.....	5
Rear	6
Installation	6
Functions	7
Set Up and Operation	11
Connection Cables	11
Maintenance	11
Troubleshooting	12
Product Specification	12
Block diagram	13
Notes	14

Warning



**FOR YOUR OWN SAFETY, PLEASE READ THIS USER MANUAL CAREFULLY
BEFORE YOUR INITIAL START-UP!**



Unpacking Instructions

Immediately upon receiving this product, carefully unpack the carton and check the contents to ensure that all parts are present and have been received in good condition. Notify the dealer immediately and retain packing material for inspection if any parts appear damaged from shipping or the carton itself shows signs of mishandling. Save the carton and all packing materials. In the event that a fixture must be returned to the factory, it is important that the fixture be returned in the original factory box and packing.

Your shipment includes:

- DAP IMIX-5.3
- Power adapter 2x18Vac 700mA
- User manual



CAUTION!
Keep this device away from rain and moisture!



Safety Instructions

Every person involved with the installation, operation and maintenance of this system has to:

- be qualified
- follow the instructions of this manual



CAUTION! Be careful with your operations.
**With a dangerous voltage you can suffer
a dangerous electric shock when touching the wires!**



Before you initial start-up, please make sure that there is no damage caused by transportation. Should there be any, consult your dealer and do not use the system.

To maintain perfect condition and to ensure a safe operation, it is absolutely necessary for the user to follow the safety instructions and warning notes written in this manual.

Please consider that damages caused by manual modifications to the system are not subject to warranty.

This system contains no user-serviceable parts. Refer servicing to qualified technicians only.

IMPORTANT:

The manufacturer will not accept liability for any resulting damages caused by the non-observance of this manual or any unauthorized modification to the system.

- Never let the power-cord come into contact with other cables! Handle the power-cord and all connections with the mains with particular caution!
- Never remove warning or informative labels from the unit.
- Never use anything to cover the ground contact.
- Never leave any cables lying around.
- Do not insert objects into air vents.
- Do not connect this system to a dimmerpack.
- Do not switch the system on and off in short intervals, as this would reduce the system's life.
- Do not open the device and do not modify the device.
- Do not drive the inputs with a signal level bigger, than required to drive the equipment to full output.
- Do not plug Mics into the console (or stagebox) while Phantom Power is on. Also mute the monitor / Pa system when turning Phantom Power on or off. Allow the system to adjust for a couple of seconds, before setting the input gains.
- Only use system indoor, avoid contact with water or other liquids.
- Avoid flames and do not put close to flammable liquids or gases.
- Always disconnect power from the mains, when system is not used. Only handle the power-cord by the plug. Never pull out the plug by tugging the power-cord.
- Always operate the unit with the AC ground wire connected to the electrical system ground.
- Make sure you don't use the wrong kind of cables or defective cables.
- Make sure that the signals into the mixer are balanced, otherwise hum could be created.
- Make sure you use DI boxes to balance unbalanced signals; All incoming signals should be clear.
- Make sure that the available voltage is not higher than stated on the rear panel.
- Make sure that the power-cord is never crimped or damaged. Check the system and the power-cord from time to time.
- Please turn off the power switch, when changing the power cord or signal cable, or select the input mode switch.
- Extreme frequency boosts in connection with a high input signal level may lead to overdriving your equipment. Should this occur, it is necessary to reduce the input signal level by using the INPUT control.
- To emphasize a frequency range, you don't necessarily have to move its respective control upward; try lowering surrounding frequency ranges instead. This way, you avoid causing the next piece of equipment in your sound path to overdrive. You also preserve valuable dynamic reserve ("headroom")
- Avoid ground loops! Always be sure to connect the power amps and the mixing console to the same electrical circuit to ensure the same phase!
- If system is dropped or struck, disconnect mains power supply immediately. Have a qualified engineer inspect for safety before operating.
- If the system has been exposed to drastic temperature fluctuation (e.g. after transportation), do not switch it on immediately. The arising condensation water might damage your system. Leave the system switched off until it has reached room temperature.
- If your Dap Audio device fails to work properly, discontinue use immediately. Pack the unit securely (preferably in the original packing material), and return it to your Dap Audio dealer for service.
- Repairs, servicing and electric connection must be carried out by a qualified technician.
- For replacement use fuses of same type and rating only.
- WARRANTY: Till one year after date of purchase.

Operating Determinations

This system is not designed for permanent operation. Consistent operation breaks will ensure that the system will serve you for a long time without defects.

If this system is operated in any other way, than the one described in this manual, the product may suffer damages and the warranty becomes void.

Any other operation may lead to dangers like short-circuit, burns, electric shock, etc.

You endanger your own safety and the safety of others!

Improper installation can cause serious damage to people and property!

Connection with the mains

Connect the device to the mains with the power-plug.
Always pay attention, that the right color cable is connected to the right place.

International	EU Cable	UK Cable	US Cable	Pin
L	BROWN	RED	YELLOW/COPPER	FASE
N	BLUE	BLACK	SILVER	NUL
	YELLOW/GREEN	GREEN	GREEN	EARTH

Make sure that the device is always connected properly to the earth!



Return Procedure



Returned merchandise must be sent prepaid and in the original packing, call tags will not be issued. Package must be clearly labeled with a Return Authorization Number (RMA number). Products returned without an RMA number will be refused. Highlite will not accept the returned goods or any responsibility. Call Highlite 0031-455667723 or mail offersales@highlite.nl and request an RMA prior to shipping the fixture. Be prepared to provide the model number, serial number and a brief description of the cause for the return. Be sure to properly pack fixture, any shipping damage resulting from inadequate packaging is the customer's responsibility. Highlite reserves the right to use its own discretion to repair or replace product(s). As a suggestion, proper UPS packing or double-boxing is always a safe method to use.

Note: If you are given an RMA number, please include the following information on a piece of paper inside the box:

- 1) Your name
- 2) Your address
- 3) Your phone number
- 4) A brief description of the symptoms

Claims

The client has the obligation to check the delivered goods immediately upon delivery for any shortcomings and/or visible defects, or perform this check after our announcement that the goods are at their disposal. Damage incurred in shipping is the responsibility of the shipper; therefore the damage must be reported to the carrier upon receipt of merchandise.

It is the customer's responsibility to notify and submit claims with the shipper in the event that a fixture is damaged due to shipping. Transportation damage has to be reported to us within one day after receipt of the delivery.

Any return shipment has to be made post-paid at all times. Return shipments must be accompanied with a letter defining the reason for return shipment. Non-prepaid return shipments will be refused, unless otherwise agreed in writing.

Complaints against us must be made known in writing or by fax within 10 working days after receipt of the invoice. After this period complaints will not be handled anymore.

Complaints will only then be considered if the client has so far complied with all parts of the agreement, regardless of the agreement of which the obligation is resulting.

Description of the device

Features

The IMIX-5.3 is a compact installation mixer with zone control. It has exact the same functionality as the IMIX-5.3 but each input on the IMIX-5.3 can be routed to the desired output. This function makes it possible to control 3 areas with different music, sound level and EQ settings.

- Gain settings at backside
- Special front input for phone/mp3 devices
- Zone control for 3 balanced outputs
- 2 Mic, 11 Line inputs.

Overview

Front

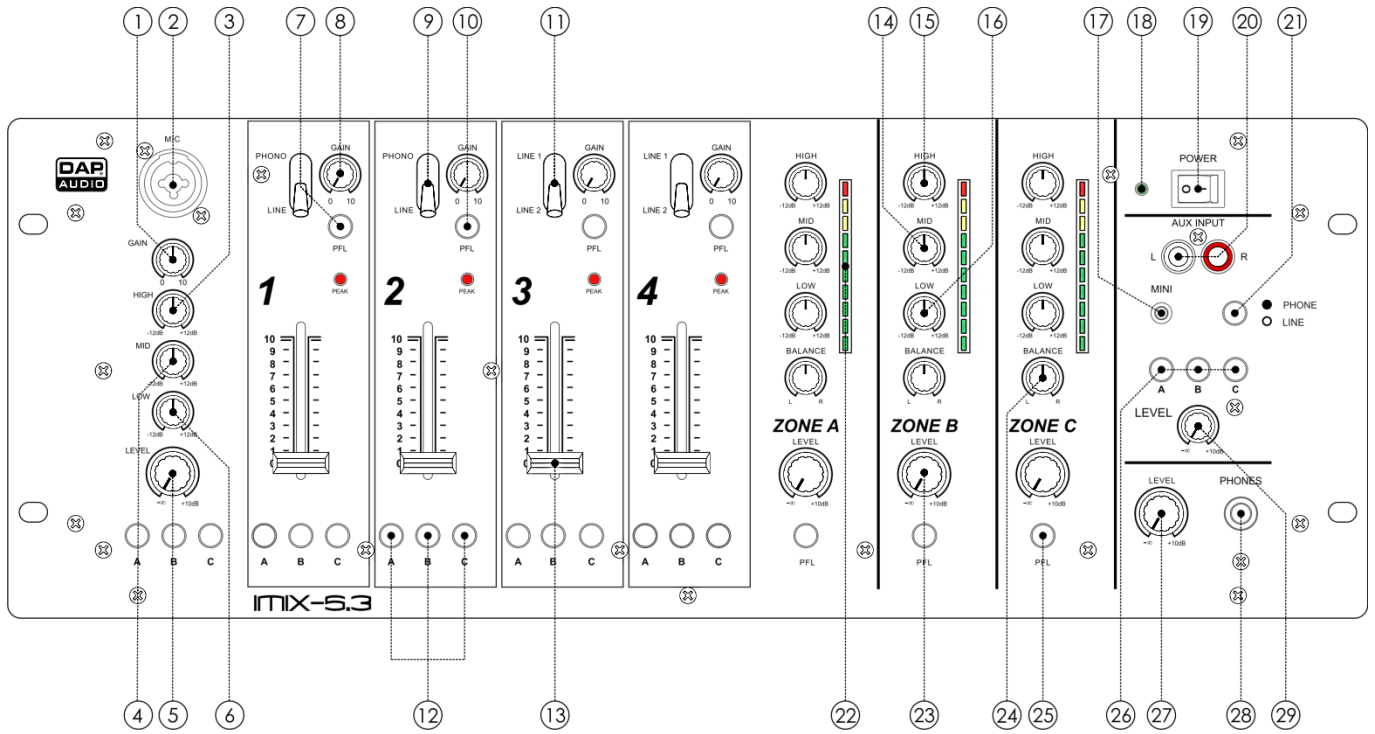

- ① Gain control (mic)
- ② Mic 1 balanced input connector
- ③ High control (mic)
- ④ Mid control (mic)
- ⑤ Mic level control
- ⑥ Low control (mic)
- ⑦ PFL button (channel 1-4)
- ⑧ Gain control (channel 1-4)
- ⑨ Input selection switch (channel 1/2)
- ⑩ Peak LED
- ⑪ Input selection switch (channel 3/4)
- ⑫ Zone assign buttons (all channels)
- ⑬ Channel fader (channel 1-4)
- ⑭ Mid control (channel 1-4)
- ⑮ High control (channel 1-4)
- ⑯ Low control (channel 1-4)
- ⑰ Aux in unbalanced mini jack input connector
- ⑱ Power on LED
- ⑲ Power on/off switch
- ⑳ Aux in unbalanced RCA input connectors
- ㉑ Phone/line button
- ㉒ VU-meter (zone A/B/C)
- ㉓ Master control (zone A/B/C)
- ㉔ Balance control (zone A/B/C)
- ㉕ PFL button (zone A/B/C)
- ㉖ Aux assign buttons
- ㉗ Headphone level control
- ㉘ Headphone output connector
- ㉙ Aux level control

Rear

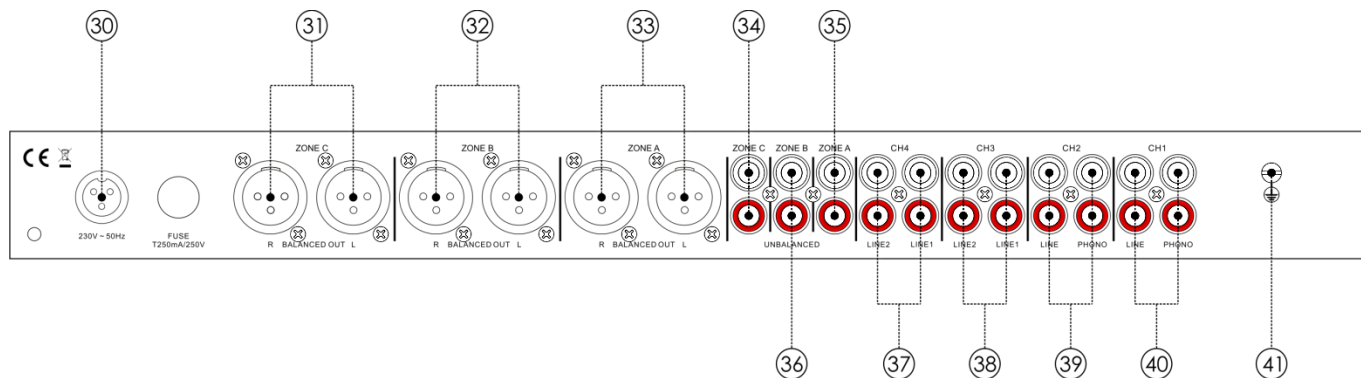

- ③⑩ IEC cable inlet
- ③① Zone C XLR balanced out connectors
- ③② Zone B XLR balanced out connectors
- ③③ Zone A XLR balanced out connectors
- ③④ Zone C RCA unbalanced out connector
- ③⑤ Zone A RCA unbalanced out connector
- ③⑥ Zone B RCA unbalanced out connector
- ③⑦ Channel 4 line 1/line 2 input connectors
- ③⑧ Channel 3 line 1/line 2 input connectors
- ③⑨ Channel 2 line input connectors
- ④① Channel 1 line input connectors
- ④① GND screw

Installation

Remove all packing materials from the IMIX-5.3. Check that all foam and plastic padding is removed. Connect all cables.

Always disconnect from electric mains power supply before cleaning or servicing. Damages caused by non-observance are not subject to warranty.

Functions

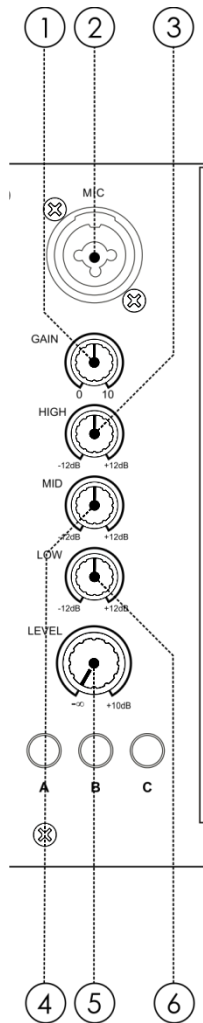

1. Mic gain control

The input sensitivity of the **Mic (2)** input is determined by the gain control. With the gain control you are able to adjust the input-sensitivity for an optimal match with the mixer's internal operation level. The high gain of this mixer is ideal when dealing with very low input levels.

2. Mic input combo connector

Electronically balanced combo-type input for connecting low impedance microphones. The input has extremely low noise and low hum. When connecting a microphone make sure that the pin assignment is correct. Always make sure to read the manual of the microphone you want to connect. The combo- input is not suitable for connecting an additional mixing console, FX- unit, etc. You have to use the **line (17,20,37-40)** inputs, when connecting this kind of equipment.

Note: When connecting signal sources, please make sure the corresponding channel faders and the master faders are at their minimum settings. Otherwise unpleasant plug-in noise can occur.

3/4/6. Equalizer section (hi/mid/low)

The microphone channel's equalizer section allows shaping of the incoming audio signal. All input channels are fitted with 3-band EQ. The high (2) and low (1) shelving controls have their frequencies fixed at 10 KHz and 100 Hz respectively. The mid (3) range control has a peaking response frequency at 1 KHz. All 3 bands have up to 12dB cut and boost, with a centre detent. Turning an equalizer control to the right amplifies the frequency range; turning to the left attenuates the signal. Minor changes to an equalizer control usually produce the best results. Try to avoid excessive enhancement of the mid band.

5. Mic level control (Mic 1/2)

Controls the volume of the corresponding microphone channel.

7. PFL button

The PFL button (pre fade listening) is designed to route the corresponding channel's input to the headphone section, independent of the individual channel's volume fader setting. It is possible to assign more than one channel simultaneous to the PFL bus.

8. Channel gain control

Channel input level is determined by the gain control. With the gain control you are able to adjust the line input-sensitivity for an optimal match with the mixer's internal operation level. The high gain of this mixer is ideal when dealing with very low input levels.

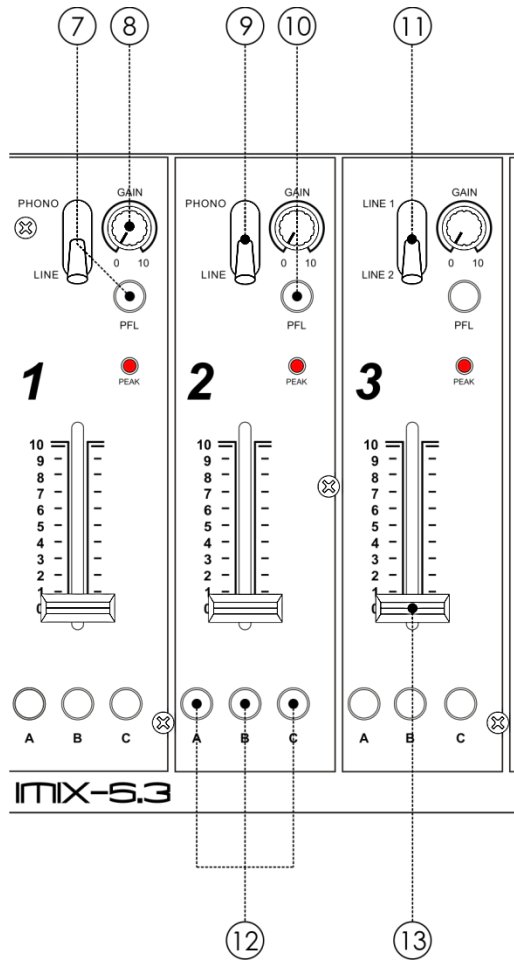

9. Input selection switch (channel 1/2)

With this you are able to assign the line inputs or the phono inputs to the according channel.

10. Peak LED

The peak LED shows peak levels in a channel's incoming signal level. If the red peak LED frequently blinks or constantly lights, the corresponding channel is likely to enter clipping and you have to reduce the input's amplification using the **gain (8)** control. The peak LED lights at a level of 8 dB below clipping. Make sure that the peak LED lights only briefly during dynamic peaks.

11. Input selection switch (channel 3/4)

With this you are able to assign two sets of line inputs to the according channel.

12. Zone assign buttons

Use these 3 buttons to assign the corresponding channel to one or more zones.

13. Channel fader

A logarithmic 50mm fader, which controls the volume of the corresponding channel. The overall volume is set with the master control.

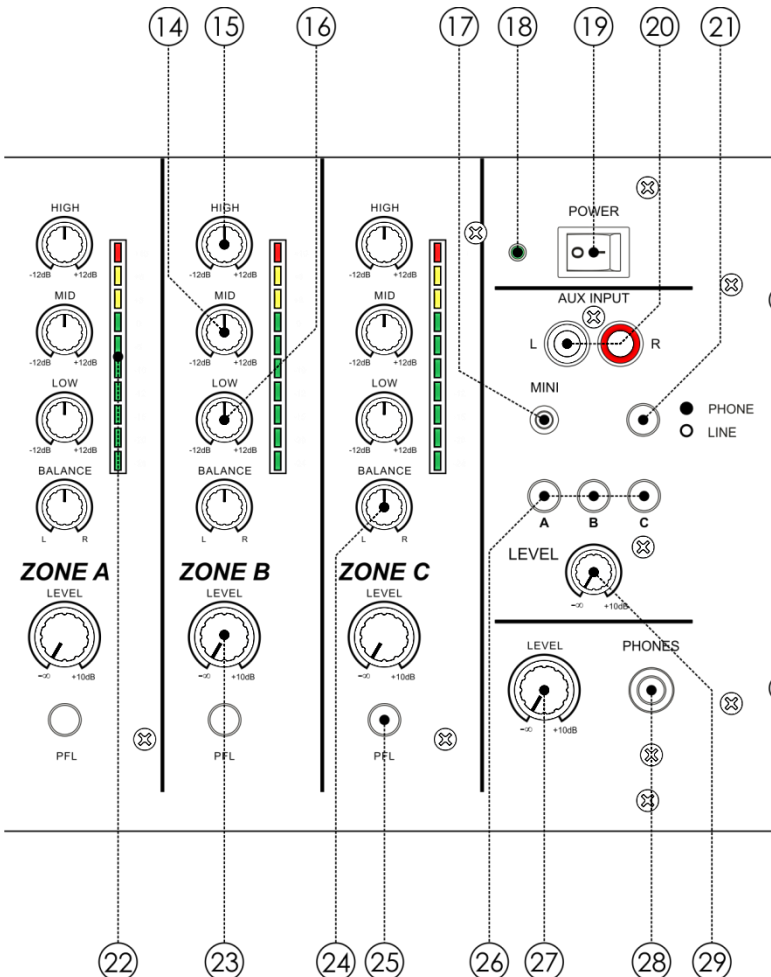

14/15/16. Equalizer section (zone A/B/C)

The zone equalizer section allows shaping of the outgoing audio signal. All input channels are fitted with 3-band EQ. The **high (15)** and **low (16)** shelving controls have their frequencies fixed at 10 KHz and 100 Hz respectively. The **mid (14)** range control has a peaking response frequency at 1 KHz. All 3 bands have up to 12dB cut and boost, with a centre detent for. Turning the equalizer control to the right amplifies the frequency range; turning to the left attenuates the signal. Minor changes to an equalizer control usually produce the best results. Try to avoid excessive enhancement of the mid band.

17. Aux mini jack in connector

Unbalanced stereo mini jack aux input for connecting a line/phones level device. Use the **phone/Line (21)** button to set up this input for connecting either headphone or line level output devices.

18. Power LED

Indicates that the IMIX-5.3 is switched on.

19. Power on/off switch

Do not supply power before the whole system is set up and connected properly.

20. Aux RCA in connectors

Unbalanced stereo RCA aux input for connecting a line/phones level device. Use the **phone/line (21)** button to set up this input for connecting either headphone or line level output devices.

21. Phone/line button

Use this button to configure both **aux (17,20)** inputs for either line level or phone level.

When the input level is too low, press the line/phone level switch. When the light is on, the level of the input signal will be boosted. The phone level adjusts the input sensitivity into the correct level for MP3 players, smartphones or tablets. Now you can playback your MP3 devices directly without signal loss.

22. Output signal VU-meter (zone A/B/C)

This meter is a multi-step LED. The accurate level indication allows you to monitor the output signal level at anytime, and match with other devices.

23. Level control (zone A/B/C)

Allows you to adjust the output signal to the **zone A/B/C (31-36, 45)** outputs.

24. Balance control (zone A/B/C)

By using the bal(ance) control you can adjust the balance between the left and the right channel.

25. PFL button

The PFL button (pre fade listening) is designed to route the corresponding zone to the headphone section. It is possible to assign more than one zone simultaneous to the PFL bus.

26. Zone assign buttons

Use these 3 buttons to assign the aux channel to one or more zones.

27. Headphones level control

This control allows you to adjust the headphones' volume.

28. Headphone out connector

You can connect a pair of headphones with an impedance of 32 - 600 Ohm to the headphones connector. It is a 6,3mm/ 1/4" TRS socket, wired as Tip=left, Ring=right and sleeve = ground.

Caution: Depending on the type of headphones connected to the Headphones jack, the IMIX-5.3 is capable of producing high output levels via the phones output. Therefore, make sure to turn the control all the way to the left (minimum setting) before connecting the headphones. Be aware of the fact that listening to loud sound pressure levels over a longer period of time leads to hearing damage!

29. Aux level control

This control allows you adjust the level of the aux (17,20) inputs in the master mix.

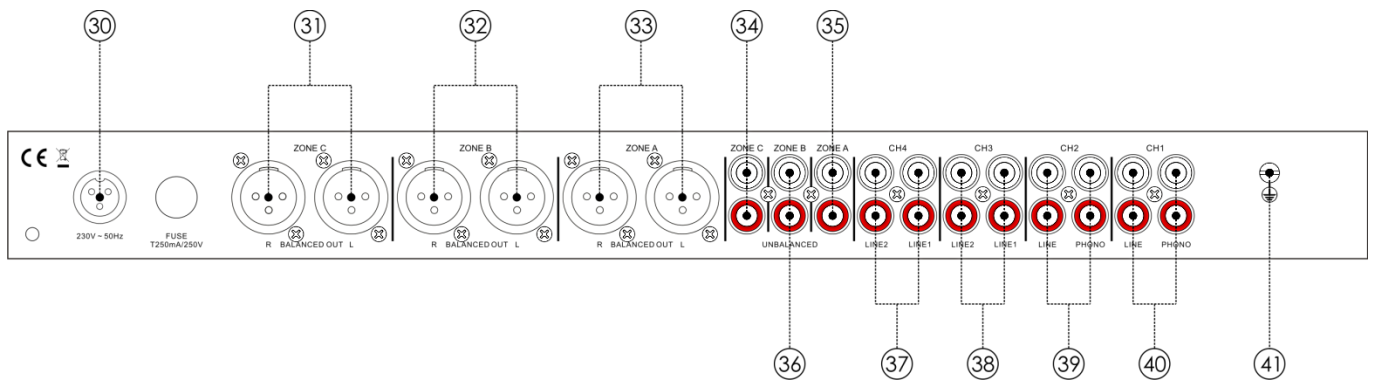

30. Power adapter connector

This is the remote AC power supply input socket for the IMIX-5.3 It is a special three core socket. Please use the supplied DAP audio adapter only.

31. Zone C XLR balanced out connectors

Use these outputs to connect an amplifier with balanced inputs.

32. Zone B XLR balanced out connectors

Use these outputs to connect an amplifier with balanced inputs.

33. Zone A XLR balanced out connectors

Use these outputs to connect an amplifier with balanced inputs.

34. Zone C RCA unbalanced out connectors

Use these outputs to connect an amplifier with unbalanced inputs.

35. Zone A RCA unbalanced out connectors

Use these outputs to connect an amplifier with unbalanced inputs.

36. Zone B RCA unbalanced out connectors

Use these outputs to connect an amplifier with unbalanced inputs.

37. Channel 4 RCA line input connectors

Use to connect a line level device. You can select one of the two line inputs with the corresponding **input selection (11)** switch on the frontpanel.

38. Channel 3 RCA line input connectors

Use to connect a line level device. You can select one of two the Line inputs with the corresponding **input selection (11)** switch on the frontpanel. Use the phono input to connect a turntable

39. Channel 2 RCA line/phono input connectors

Use the line input to connect a line level device. Use the phono input to connect a turntable.

40. Channel 1 RCA line/phono input connectors

Use the line input to connect a line level device. Use the phono input to connect a turntable.

41. GND screw

Use to connect the ground wire of your turntable.

Set Up and Operation

Before plugging the unit in, always make sure that the power supply matches the product specification voltage. Do not attempt to operate a 115V specification product on 230V power, or vice versa.

Connection Cables

Take care of your cables, always holding them by the connectors and avoiding knots and twists when coiling them: This gives the advantage of increasing their life and reliability. Periodically check your cables. A great number of problems (faulty contacts, ground hum, discharges, etc.) are caused entirely by using unsuitable or faulty cables.

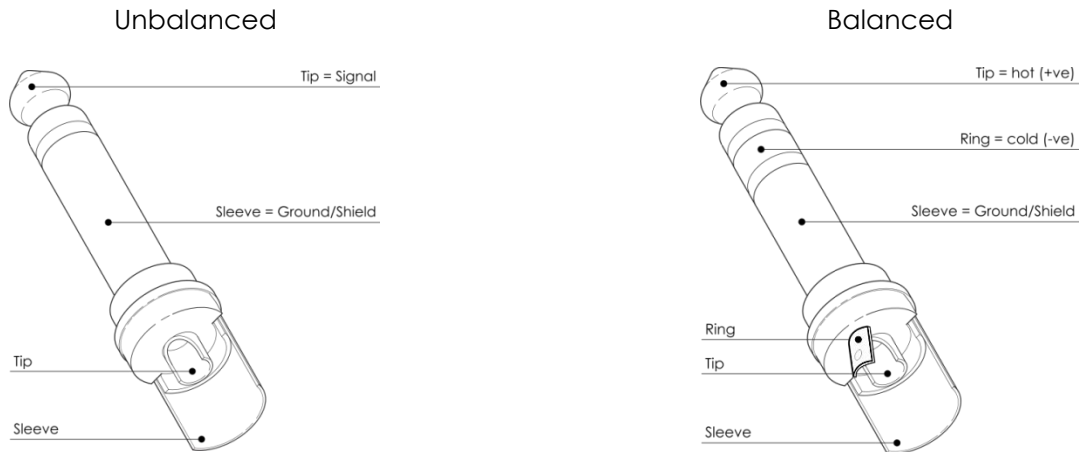

For these applications the unit provides 1/4" TRS and XLR connectors to easily interface with most professional audio devices. Follow the configuration examples below for your particular connection.

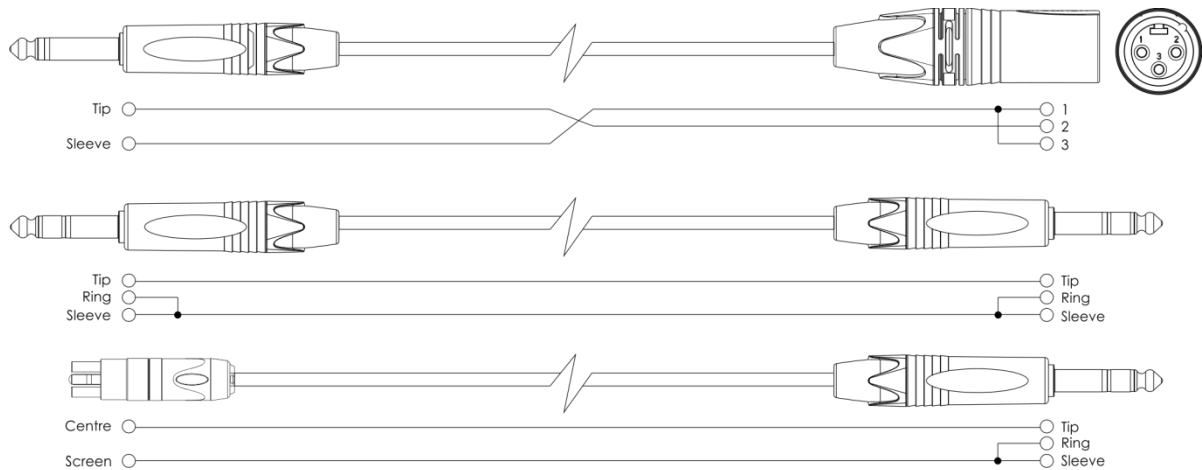

Maintenance

The DAP Audio IMIX-5.3 requires almost no maintenance. However, you should keep the unit clean. Disconnect the mains power supply, and then wipe the cover with a damp cloth. Do not immerse in liquid. Do not use alcohol or solvents.

Keep connections clean. Disconnect electric power, and then wipe the audio connections with a damp cloth. Make sure connections are thoroughly dry before linking equipment or supplying electric power.

Troubleshooting

DAP Audio IMIX-5.3

This troubleshooting guide is meant to help solve simple problems. If a problem occurs, carry out the steps below in sequence until a solution is found. Once the unit operates properly, do not carry out following steps.

1. If the device does not operate properly, unplug the device.
2. Check power from the wall, all cables, connections, etc.
3. If all of the above appears to be O.K., plug the unit in again.
4. If nothing happens after 30 seconds, unplug the device.
5. Return the device to your DAP Audio dealer.

Product Specification

Input channels

1 x Microphone, combo XLR/Jack
7 x Line, RCA
2 x Phono, RCA
1 x Phone, 3,5mm jack

Output channels

3 x Master (Balanced), XLR/RCA
1 x Headphones, 6.3mm Jack

Other specifications

Master EQ:	100 Hz, 1 KHz, 10 KHz, -12 dB / +12 dB
Mic EQ:	100 Hz, 1 KHz, 10 KHz, -12 dB / +12 dB
Frequency response:	20 Hz – 20Khz
T.H.D.:	<0.05%
Dimensions:	483 x 176 x 83 mm (WxHxD)
Size:	19", 4HE
Power adapter:	2x 18Vac, 700mA
Powerconsumption:	15Watt
Weight:	4 Kg

Design and product specifications are subject to change without prior notice.

Block diagram

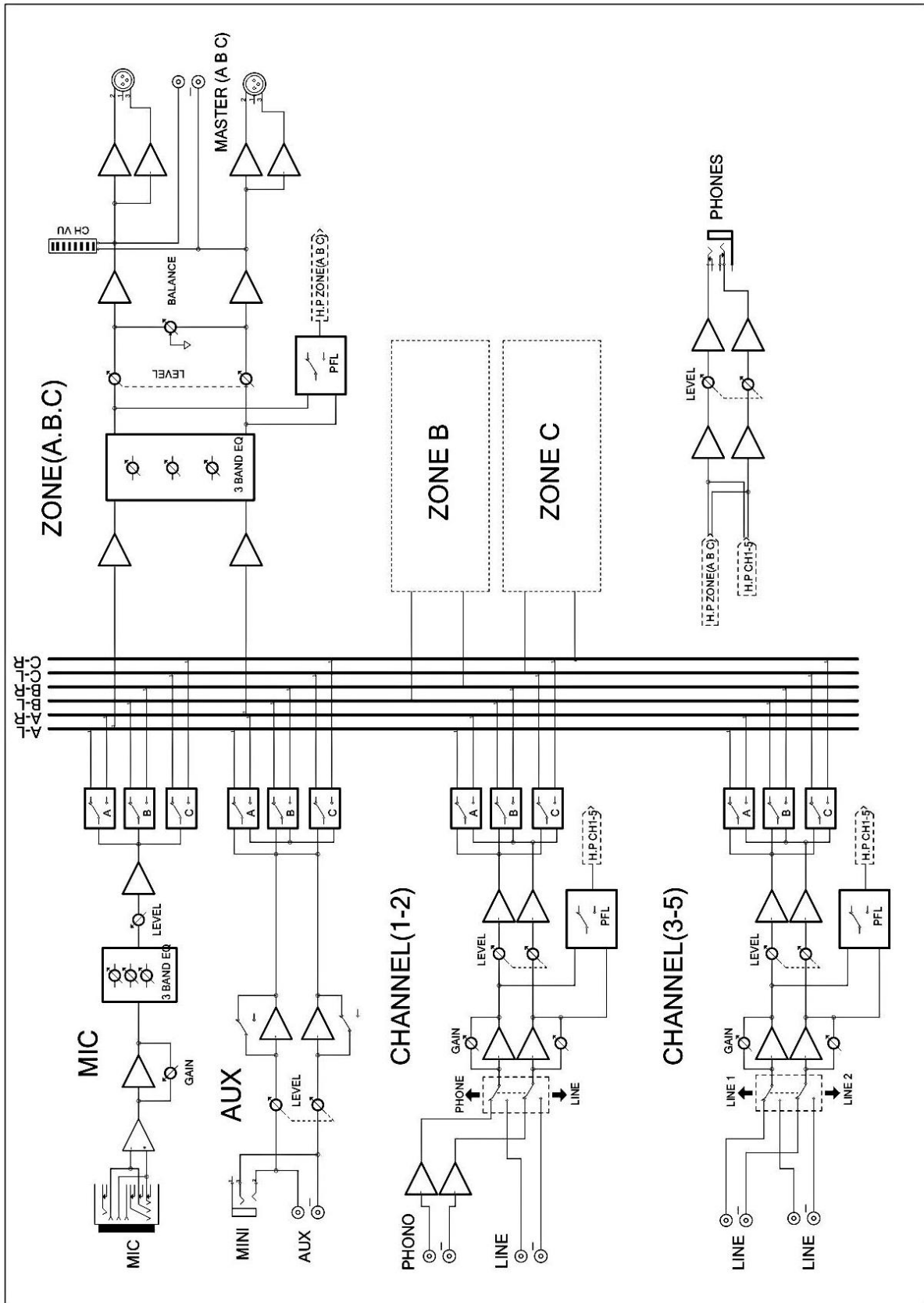



©2013 DAP Audio