



MX-2070

OWNER'S MANUAL

**PROFESSIONAL MICROPHONE MIXER
WITH
DIGITAL ECHO
PARAMETRIC & GRAPHIC
EQUALIZER**



FEATURES:

- # 6 MICROPHONE PREAMPLIFIERS WITH INDEPENDENT LEVEL CONTROL
- # 3 BAND PARAMETRIC EQUALIZER FOR MICROPHONES, FEATURES SWEEP-MIDRANGE CONTROL TO LIFT PARTICULAR CHARACTERISTICS OF THE VOCAL OR SUPPRESSED FOR FEED BACK ELIMINATION
- # DIGITAL ECHO WITH REPEAT AND DELAY CONTROLS HELPS SINGER SOUND GREAT
- # DUAL 7 BAND STEREO EQUALIZER FOR PRECISE ROOM TUNING
- # DUAL SOURCE AUDIO/VIDEO INPUT CONNECTS TO DVD, CDG, OR VIDEO CASSETTE PLAYERS
- # VOCAL CANCEL FEATURE ELIMINATES GUIDE VOCAL ON MULTIPLES CD OR CASSETTE TAPES
- # COMPACT 1-SPACE DESIGN SAVES VALUABLE RACK SPACE

Front Panel

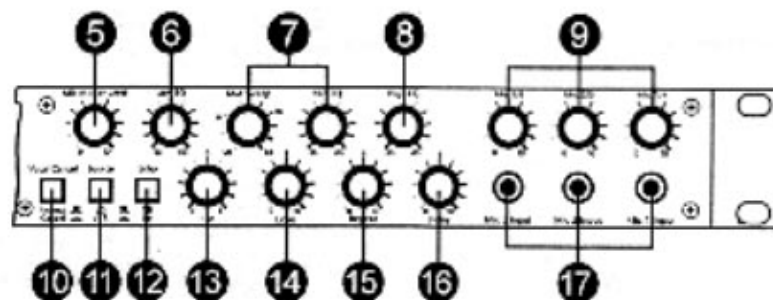
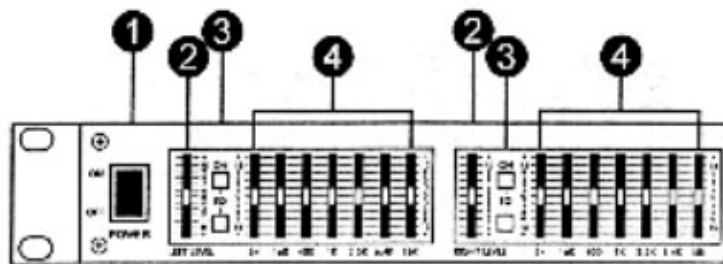

1. **Power switch** : Turn switch on to apply power to the mixer.
2. **Level Control** : Controls for the input levels.
3. **EQ On switch** : This buttons with LEDs to activate the equalizer adjustments.
4. **Level Control** : The graphic equalizer is a stereo 7 band type, with center frequencies of 60Hz, 140Hz, 400Hz, 1KHz, 2.5KHz, 6.4KHz, 16KHz. The equalizer provides much more precise control than conventional tone controls. Each slide control can provide up to 15dB of cut and boost.
5. **Mic Master Level** : The master level control the final output level of the microphones input to the outputs.
6. **Low EQ** : Low frequency is a shelving type and provides boost/cut control of 15 dB.
7. **Mid & Mid Sweep** : Mid control is a peak/dip type and arranged as a boost/cut of 15 dB. Sweep control which determines at which frequency the boost/cut action will be centered.
8. **High EQ** :High frequency is a shelving type and provides boost/cut control of 15 dB.
9. **Mic level** : These six knobs acts as a sensitivity control and covering 40 dB range.
10. **Vocal Cut** : On/Off Button is used to eliminates the guide vocal on multiple CD or cassette tape.
11. **Source** : Button is used to selected two stereo line level (like LD,VCR,DVD) audio/video inputs signal synchronously.
12. **Echo** : On/Off button to activate the digital echo adjustments.
13. **Pan** : Control determines the position of the signal within the stereo image.
14. **Echo** : Controls the level of the digital echo.
15. **Repeat** : Controls the number of the echo repetitions.
16. **Delay** : Controls the delay time of the echo
17. **Mic 1~3 input** : The signal of microphone 1~3 is via these six 6.3Φ connectors to the input stage.

Rear Panel

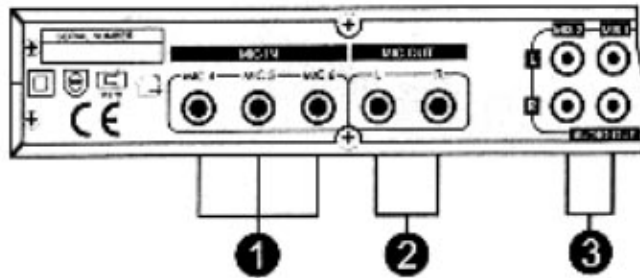

① ② ③



④ ⑤ ⑥ ⑦

1. **Mic 4~6 input** : The signal of microphone 4~6 is via these six 6.3Φ connectors to the input stage.
2. **Mic L/R output** : The left & right signal of microphone is via these two 6.3Φ connector to the output.
3. **Mix 1,2 output** : The output jacks of mixed signal of microphone & line.
4. **Line output** : The output jacks of line.
5. **Audio input** : The audio input jacks of LD,VCR,DVD etc.
6. **Video input** : The video input jacks of LD,VCR,DVD etc.
7. **Video 1,2 output** : The output jacks of video out, one for TV, and other one for video cassette recorder.

Specifications

Graphic Equalizer:

Connector.....	RCA/Unbal.
Input impedance.....	47KΩ
Gain.....	0 dB
Bands.....	1 ¹ / ₃ ISO Spacing
Range.....	+/-15 dB
T.H.D.....	<0.01%
Frequency Response.....	10Hz~50KHz -1 dB
Noise Ratio.....	>90 dB

Microphone:

Connector.....	1/4"TRS/Unbal.
Input Impedance.....	1.5KΩ
T.H.D.....	<0.1%
Noise Ratio.....	>80 dB
High.....	+/-15 dB
Mid.....	+/-15 dB
Mid Freq.....	250Hz~6KHz
Low.....	+/-15 dB
Delay Time.....	up to 300 mS

BASIC CONNECTIONS

