



ASSEMBLY INSTRUCTION

XLR Chassis TOP | NC*FDX-TOP with SCFDX-TOP
NC*MDX-TOP with SCMDX-TOP

IP65 RATED AND UL50E APPROVED.

1 Connector installation

Any TOP XLR chassis connector

4x Screws

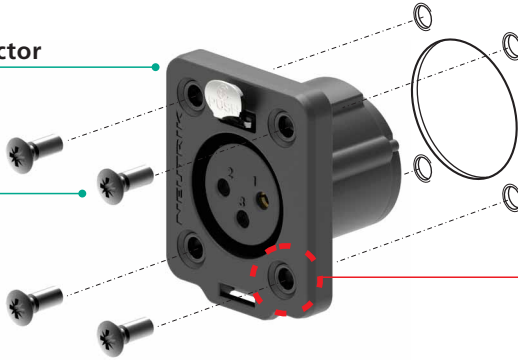

ATTENTION:
Tightening torque
MA = 40 Ncm

Equipment / Panel



Lubricate O-Gasket
with silicon on all
4 screw holes.

2 Mount the sealing cover



A Insert the ribbon through the dedicated slot.

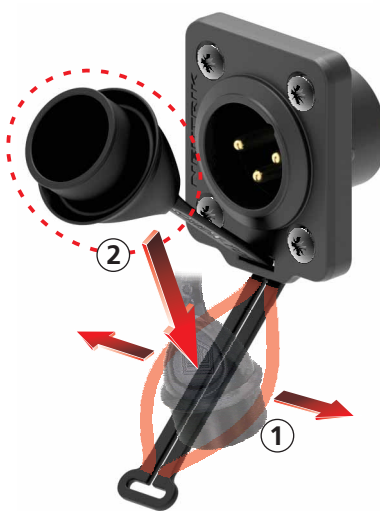

B (1) Split the ribbon and (2) put through the cover.



C Tighten the ribbon

3 Panel Cutout (Rear Side)

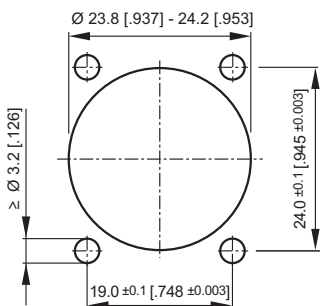

4 Recommended screw

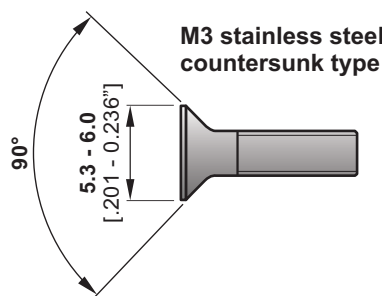

Find more details of
XLR Chassis on
www.neutrik.com.



Neutrik AG	LI	T: +423 / 237 24 24	F: +423 / 232 53 93	Neutrik France	FR	T: +33 1 / 4131 6750	F: +33 1 / 4131 0511
Neutrik USA Inc.	USA	T: +1 704 / 972 3050	F: +1 704 / 438 9202	Neutrik Tokyo Ltd.	JP	T: +81 3 / 3663 4733	F: +81 3 / 3663 4796
Neutrik (UK) Ltd.	UK	T: +44 1983 / 811 441	F: +44 1983 / 811 439	Neutrik Hong Kong Ltd.	HK	T: +852 / 2687 6055	F: +852 / 2687 6052
Neutrik Vertriebs GmbH	DE/NL/AT/DK	T: +49 8131 / 280 890	F: +49 8131 / 280 830	Neutrik India Pvt. Ltd.	IND	T: +91 / 982 05 43 424	F: +91 / 22 26163 540

Draft. Nr.: BDA 553 | Update: 13.09.2018 | Data subject to change without prior notice. © 2018 NEUTRIK®. NEUTRIK® are registered trademark of NEUTRIK AG. ALL RIGHTS RESERVED.

www.neutrik.com