

# AirLine 88x

## Guitar Wireless System



OWNER'S MANUAL

**SAMSON®**

Copyright 2019, Samson Technologies Corp.

v3

This product is covered by the US patent: US9,602,053

Samson Technologies Corp.  
278-B Duffy Ave  
Hicksville, NY 11801  
[www.samsontech.com](http://www.samsontech.com)

# Important Safety Information



**ATTENTION  
RISQUE D'ÉLECTROCUTION !  
NE PAS OUVRIR !**

CAUTION: TO REDUCE THE RISK OF ELECTRIC SHOCK, DO NOT REMOVE COVER (OR BACK). NO USER-SERVICEABLE PARTS INSIDE. REFER SERVICING TO QUALIFIED SERVICE PERSONNEL.



This lightning flash with arrowhead symbol within an equilateral triangle is intended to alert the user to the presence of non-insulated "dangerous voltage" within the product's enclosure that may be of sufficient magnitude to constitute a risk of electric shock.



The exclamation point within an equilateral triangle is intended to alert the user to the presence of important operating and maintenance instructions in the literature accompanying the appliance.

## WARNING

TO PREVENT FIRE OR SHOCK HAZARD. DO NOT USE THIS PLUG WITH AN EXTENSION CORD, RECEPTACLE OR OTHER OUTLET UNLESS THE BLADES CAN BE FULLY INSERTED TO PREVENT BLADE EXPOSURE. TO PREVENT FIRE OR SHOCK HAZARD. DO NOT EXPOSE THIS APPLIANCE TO RAIN OR MOISTURE. TO PREVENT ELECTRICAL SHOCK, MATCH WIDE BLADE PLUG TO WIDE SLOT AND FULLY INSERT.



If you want to dispose this product, do not mix it with general household waste. There is a separate collection system for used electronic products in accordance with legislation that requires proper treatment, recovery and recycling.

Private household in the 28 member states of the EU, in Switzerland and Norway may return their used electronic products free of charge to designated collection facilities or to a retailer (if you purchase a similar new one).

For Countries not mentioned above, please contact your local authorities for a correct method of disposal.

By doing so you will ensure that your disposed product undergoes the necessary treatment, recovery and recycling and thus prevent potential negative effects on the environment and human health.

# Important Safety Information

1. Read these instructions.
2. Keep these instructions.
3. Heed all warnings.
4. Follow all instructions.
5. Do not use this apparatus near water.
6. Clean only with dry cloth.
7. Do not block any ventilation openings. Install in accordance with the manufacturer's instructions.
8. Do not install near any heat sources such as radiators, heat registers, stoves, or other apparatus (including amplifiers) that produce heat.
9. Do not defeat the safety purpose of the polarized or grounding type plug. A polarized plug has two blades with one wider than the other. A grounding type plug has two blades and a third grounding prong. The wide blade or the third prong are provided for your safety. If the provided plug does not fit into your outlet, consult an electrician for replacement of the obsolete outlet.
10. Protect the power cord from being walked on or pinched particularly at the plugs, convenience receptacles, and at the point where they exit from the apparatus.
11. Only use attachments/accessories specified by the manufacturer.
12. Use only with the cart, stand, tripod, bracket, or table specified by the manufacturer, or sold with the apparatus. When a cart is used, use caution when moving the cart/apparatus combination to avoid injury from tip-over.
13. Unplug the apparatus during lightning storms, or when unused for long periods of time.
14. Refer all servicing to qualified personnel. Service is required when the apparatus has been damaged in any way, such as power supply cord or plug is damaged, liquid has been spilled or objects have fallen into the apparatus has been exposed to rain or moisture, does not operate normally, or has been dropped.
15. This appliance shall not be exposed to dripping or splashing water and that no object filled with liquid such as vases shall be placed on the apparatus.
16. Caution-to prevent electrical shock, match wide blade plug wide slot fully insert.
17. Please keep a good ventilation environment around the entire unit.
18. The direct plug-in adapter is used as disconnect device, the disconnect device shall remain readily operable.
19. Batteries (battery pack or batteries installed) shall not be exposed to excessive heat such as sunshine, fire or the like.



# Important Safety Information

## FCC Rules and Regulations

Samson wireless receivers are certified under FCC Rules part 15 and transmitters are certified under FCC Rules part 74. Licensing of Samson equipment is the user's responsibility and licensability depends on the user's classification, application and frequency selected.

This device complies with Part 15 of the FCC rules Class B and RSS-210 of Industry & Science Canada.

Operation is subject to the following two conditions:

- (1) This device must not cause harmful interference, and
- (2) This device must accept any interference received including interference that may cause undesired operation. Suitable for home or office use.

NOTE: This equipment has been tested and found to comply with the limits for a Class B digital device, pursuant to Part 15 of the FCC Rules. These limits are designed to provide reasonable protection against harmful interference in a residential installation. This equipment generates, uses and can radiate radio frequency energy and, if not installed and used in accordance with the instructions, may cause harmful interference to radio communications. However, there is no guarantee that interference will not occur in a particular installation. If this equipment does cause harmful interference to radio or television reception, which can be determined by turning the equipment off and on, the user is encouraged to try to correct the interference by one or more of the following measures:

- Reorient or relocate the receiving antenna.
- Increase the separation between the equipment and receiver.
- Connect the equipment into an outlet on a circuit different from that to which the receiver is connected.
- Consult the dealer or an experienced Radio/TV technician for help.

WARNING: Changes or modifications not expressly approved by the party responsible for compliance could void the user's authority to operate the equipment.

This equipment is intended for use in wireless microphone applications.

Equipment is intended for sale in: AT, BE, CH, CY, CZ\*, DK, EE, FI\*, FR\*, DE\*, GR\*, HU, IE, IS, IT, LV, LT\*, LU, MT\*, NL, NO\*, PL\* PT, RO, SK, SI, ES, SE, UK

\*Subject to license. Please contact your national frequency authority for information on available legal use in your area. Any changes or modifications not expressly approved by Samson Technologies Corp. could void your authority to operate the equipment.

Hereby, Samson Technologies Corp., declares that this CR88x, CH88 and CB88 are in compliance with the essential requirements and other relevant provisions of Directive 2014/53/ EU. The declaration of conformity may be consulted at:

[http://www.samsontech.com/site\\_media/support/manuals/AirLine88x\\_AG8\\_DOC.pdf](http://www.samsontech.com/site_media/support/manuals/AirLine88x_AG8_DOC.pdf)

# Introduction

Congratulations on purchasing the Samson AirLine 88x AG8 Guitar system. The AirLine 88x offers true wireless freedom without the hassle of a belt-pack or cable. Featuring a plug-in transmitter with a dual-position connector that is designed to fit a variety of guitar jacks, the system provides professional sound, premium reliability and a 300' operating range, freeing you to roam the stage. Offering frequency-agile UHF operation, the CR88x receiver provides 100 available channels to secure reliable wireless performance. The receiver provides easy setup with 1-touch scan that analyzes and selects the clearest operating channel and infrared set to pair the transmitter with the receiver.

The AirLine 88 AG8 system continues Samson's longstanding commitment to wireless innovation. Designed to be an extension of your instrument rather than a separate component, the AG8 Guitar Transmitter lets you rule the stage with confidence. The AirLine 88x system ensures clear, interruption-free performance by combining tone-key with auto-mute. This configuration allows only the transmitter's audio to pass through the receiver, and mutes the output if there is any interference. For travel or permanent installation, the AirLine 88x includes a standard 19" rackmount kit.

In these pages, you'll find a detailed description of the features of the AirLine 88x wireless system, as well as a guided tour through its control panel, step-by-step instructions for its setup and use, and full specifications. If your wireless system was purchased in the United States, you'll also find a warranty card enclosed—don't forget to fill it out and mail it in so that you can receive online technical support and so that we can send you updated information about this and other Samson products in the future. Also, be sure to check out our website ([www.samsontech.com](http://www.samsontech.com)) for complete information about our full product line.

We recommend you keep the following records for reference, as well as a copy of your sales receipt.

Receiver Serial number: \_\_\_\_\_

Transmitter Serial number: \_\_\_\_\_

Date of purchase: \_\_\_\_\_

Dealer name: \_\_\_\_\_

If you have any questions or comments regarding the AirLine 88x AG8 Guitar system or any other products from Samson, do not hesitate to contact us at [support@samsontech.com](mailto:support@samsontech.com).

With proper care and maintenance, your AirLine 88x System will operate trouble-free for many years. Should your AirLine 88x System ever require servicing, a Return Authorization (RA) number must be obtained before shipping your unit to Samson. Without this number, the unit will not be accepted. Please visit [www.samsontech.com/ra](http://www.samsontech.com/ra) for an RA number prior to shipping your unit. Please retain the original packing materials and, if possible, return the unit in its original carton. If your AirLine 88x System was purchased outside of the United States, contact your local distributor for warranty details and service information.

# Quick Start

***In order for your wireless system to work correctly, both the receiver and transmitter must be set to the same channel.***

Follow this basic procedure for setting up and using your AirLine 88x Guitar wireless system:

Physically place the CR88x receiver where it will be used, and extend the antennas vertically. The general rule of thumb is to maintain “line of sight” between the receiver and transmitter so that the person using the transmitter can see the receiver.

With the CR88x receiver powered off, connect the included power adapter. Turn the CR88x on momentarily to confirm that the unit is receiving power. You’ll see the LED display light up. Then turn the CR88x power off.

With your amplifier or mixer off and volume control all the way down, connect the CR88x receiver to the input of an amplifier or the mic or line level input of a mixer using the balanced XLR output or unbalanced 1/4” output. Turn the Level knob on the CR88x completely counterclockwise, then turn its power on.

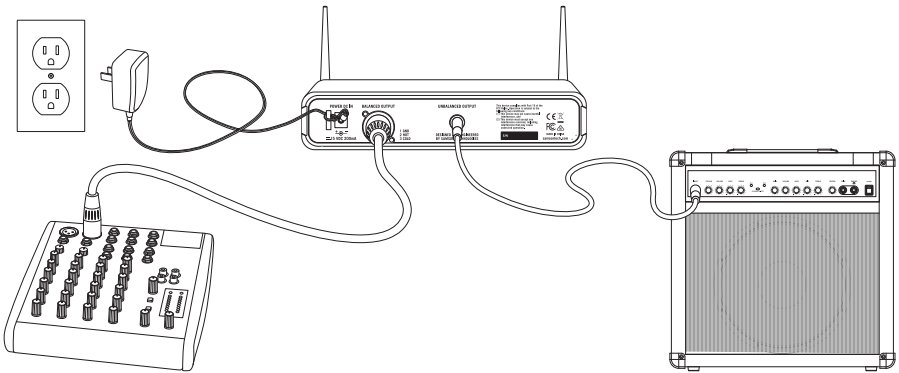

With the AG8 powered off, install a fresh AA battery. Be sure to observe the plus and minus polarity markings.

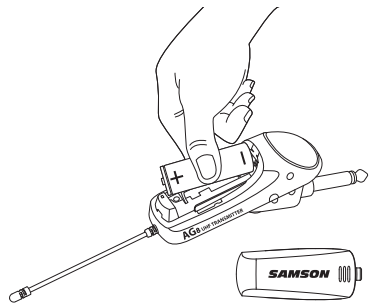

Turn on the power to the transmitter by sliding the Power switch to the left.

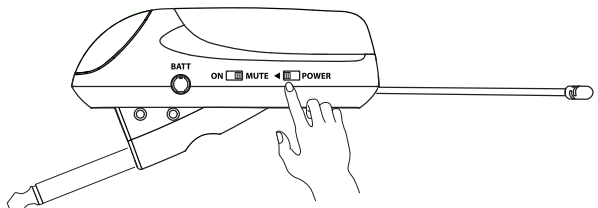

# Quick Start

Press the SCAN button for more than 2 seconds (the display will start to flash quickly) on the front of the CR88x receiver to scan for an available channel. Once the optimal channel is selected the receiver will enter IR Set mode. The display will flash slowly in IR Set mode.

If you want to set a transmitter to the receiver's currently selected channel, press and hold the SCAN button for more than 10 seconds (until the display flashes slowly) to enter IR Set mode directly.

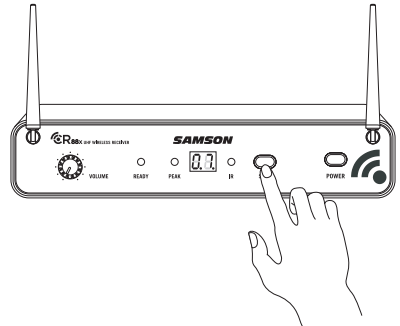

Position the AG8 transmitter about 3–12" (8–30 cm) from the front of the CR88x with the transmitter's IR window facing the IR transmitter on the front panel of the CR88x receiver.

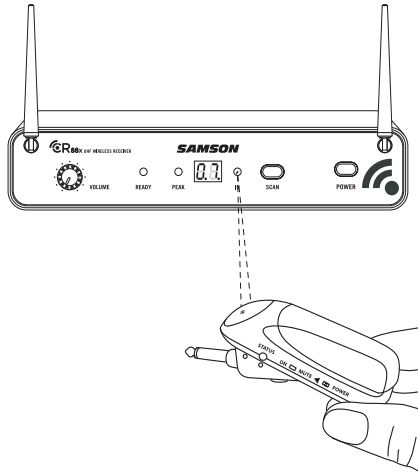

*Note: The AG8 will only accept infrared transmission from the receiver for the first 10 seconds after the AG8 is powered on. If you need to change the operating channel, the AG8 must be first powered off, then powered on again to receive the new channel.*

When the transmission is complete, the CR88x will receive RF signal and the tone key from the transmitter. The READY indicator will light on the front panel of the CR88x receiver.

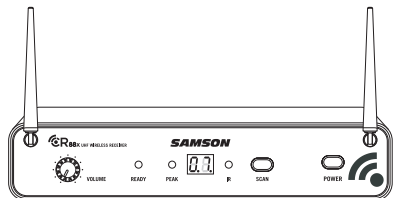



# Quick Start - Single System Setup

When the transmission is complete, the CR88x will receive RF signal and the tone key from the transmitter. The READY indicator will light on the front panel of the CR88x receiver.

Turn on your connected amplifier or mixer, but keep the volume all the way down. Set the Volume knob on the CR88x fully clockwise (to its "10" setting). This is unity gain.

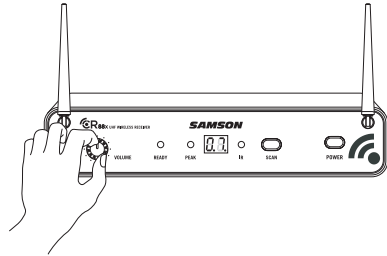

Play your instrument at normal performance level. Slowly raise the volume of your amplifier or mixer until the desired level is reached.

If you find the system has noticeable dropouts, reduced overall working range, or unexpected noise bursts, change the operating channel of the system using the steps above.

---

---

## Multiple System Setup

**When using multiple systems, each system must be set to a different operating channel.** Transmitter and receiver pairs must be on the same channel plan in order to work together.

When setting an additional transmitter, make sure to move all other transmitters away from the CR88x receiver to prevent setting multiple transmitters to the same channel.

# Setting the Plug for your Guitar

The AG8 plug can be configured for Fender Stratocaster™-type (angled) recessed jacks, and in a second position designed to be used with all other instruments that have end mount-jacks.

To configure the AG8 for Fender Stratocaster™ (angled jack) or flat jack style guitars, remove the thumbscrew, unscrew the plug and reinstall the two screw components while swapping their positions.

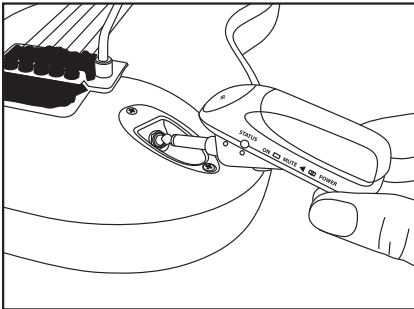
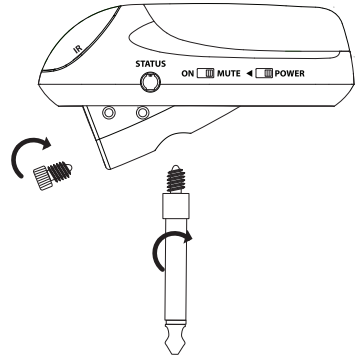
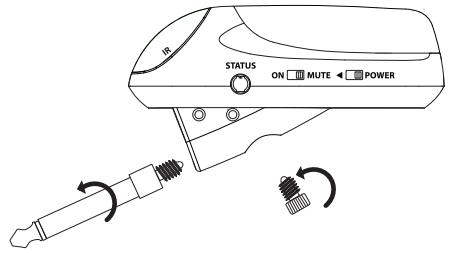

Fender Stratocaster™-type jack

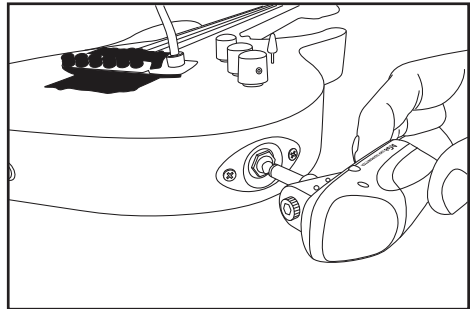

End Mount-type jack

# AG8 Callouts

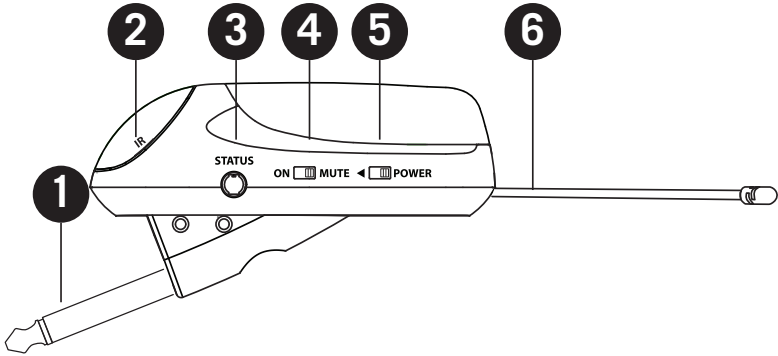

- 1. 1/4" Phone Plug** - Insert this standard 1/4" plug into your electric guitar or electric bass. *Note that the position of the plug can be configured for Fender Stratocaster™ type recessed jacks, and in a second position designed to be used with all other instruments that have end mount-jacks. If you need to change the phone plug configuration, simply remove the thumbscrew from the covered jack position, unscrew the plug and reinstall the two components while swapping their positions.*
- 2. IR Lens** - This window is used to capture the infrared signal sent from the CR88x receiver during the IR SET to channelize the transmitter. The IR Lens is only active for the first 10 seconds the transmitter is powered on.
- 3. STATUS LED** - This two color indicator shows the status of the AG8 transmitter.

Amber	Mute
Red	Peak
Flashing Red	Low Battery
- 4. MUTE Switch** - This switch is used to temporarily turn off the audio output of the transmitter. Move this switch in the direction of "MUTE" to turn off the output and move the switch in the direction of "ON" to turn the audio on.
- 5. Power switch** - Move this switch in the direction of the arrow to turn the AG8 power on; move it to the right to turn the power off.
- 6. Antenna** - This permanently attached flexible antenna should be fully extended during normal operations.

# AG8 Callouts

- 7. **Battery cover** - Pull back gently on this cover at the ribbing and pry upwards to remove.
- 8. **Battery compartment** - Insert a standard AA (LR6) alkaline battery here, being sure to observe the plus and minus polarity markings shown. Although rechargeable Ni-Cad batteries can be used, they do not supply adequate current for more than four hours of operation.  
**WARNING: Do not insert the battery backwards; doing so can cause severe damage to the AG8 and will void your warranty.**  
**Note: Attention should be drawn to the environmental aspects of battery disposal.**
- 9. **Gain control** - This miniature trimmer is used to fine tune the AG8's input sensitivity. Use the included screwdriver to make the adjustments.

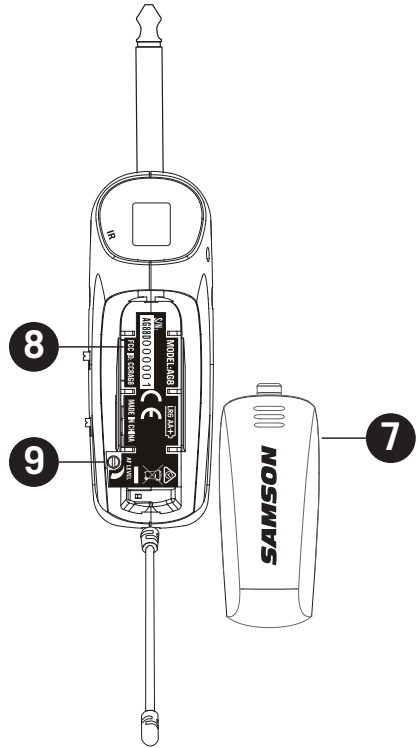

# CR88x Receiver Features - Front Panel

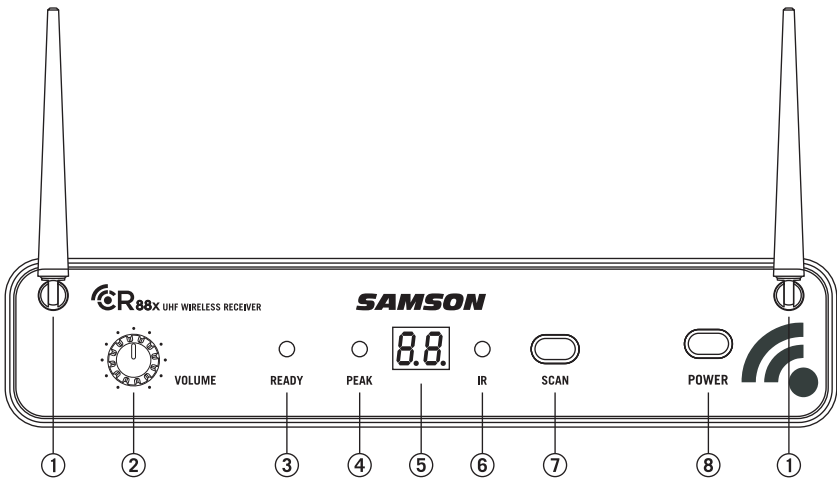

1. **Antennas** - The antenna mountings allow full rotation for optimum placement. In normal operation, both antennas should be placed in a vertical position. Both antennas can be folded inward for convenience when transporting the CR88x.
2. **VOLUME Control** - This knob sets the level of the audio signal being output through both the balanced and unbalanced output jacks on the rear panel. Reference level is obtained when the knob is turned fully clockwise (to its "10" setting).
3. **READY Indicator** - This indicator lights green when the CR88x is receiving RF signal and the system is ready to use.
4. **PEAK Indicator** - This indicator lights red when the transmitted audio signal is overloaded.
5. **LED Display** - The two digit, 7-segment LED display shows the receiver's current operating channel.
6. **IR Transmitter** - During "IR SET" an infrared light is used to set the transmitter channel.
7. **SCAN Button** - Press this button for **more than 2 seconds** to enter scan mode, the display will flash quickly. The receiver will scan through the 100 operating channels to find the optimal channel for performance. Once the scan is complete, the CR88x will enter IR Set mode and send the selected channel to the transmitter. Press and hold the button for **more than 10 seconds** to enter IR set mode, the display will flash slowly. This will send the receiver's current selected channel to the transmitter.
8. **POWER Switch** - Use this to turn the CR88x power on and off.

# CR88x Receiver Features - Rear Panel

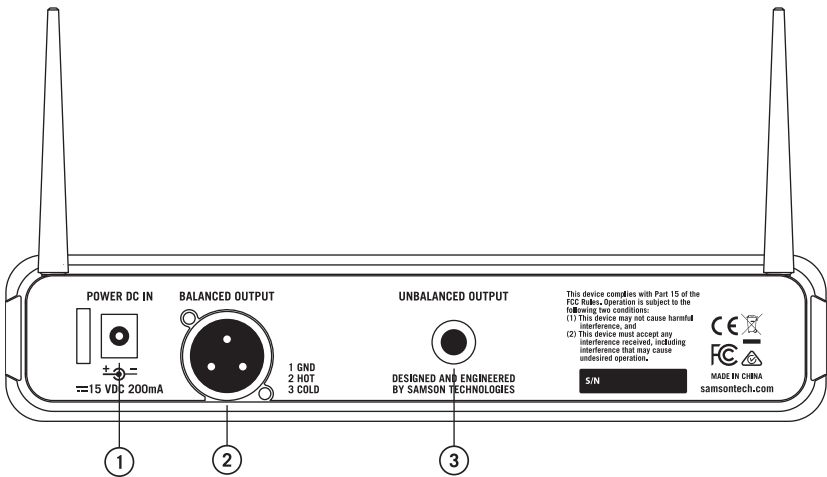

1. **DC Input** - Connect the supplied power adapter here, using the strain relief as shown in the illustration below. **WARNING:** Do not substitute any other kind of power adapter. Doing so can cause severe damage to the CR88x and will void your warranty.
2. **BALANCED OUTPUT** - Use this electronically balanced low impedance (600 Ohm) XLR jack when connecting the CR88x to professional (+4dBu) audio equipment. Pin wiring is as follows: Pin 1 ground, Pin 2 high (hot), and Pin 3 low (cold).
3. **UNBALANCED OUTPUT** - Use this unbalanced high impedance (5K Ohm) 1/4" jack when connecting the CR88x to consumer (-10dBV) audio equipment. Wiring is as follows: tip hot, sleeve ground.

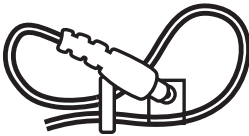

*Using the strain relief: Gather up a loop of wire and pass it through the strain relief, then pass the adapter plug through the loop in order to create a knot.*

# Rack Mounting

The CR88x receiver can be installed into a standard 19" rack for transport or permanent installation using the included rack ears. Follow the simple steps below to mount the CR88x:

Attach the included rack ears by sliding each rack ear into the groove on either side of the CR88x until they lock into place, and the receiver flush with the front panel.

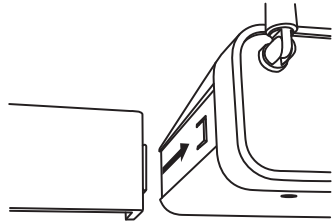

Position the CR88x receiver into an available rack space and slide in until the rack ears are touching the rails of the rack case and are aligned with the rack rail holes.

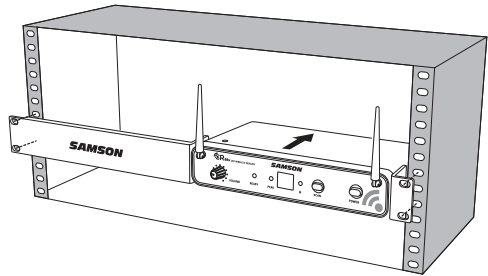

Mount the receiver into the rack using the appropriate size rack screws (not included). To ensure equal tension and balance when installing the receiver, you should secure screws in a crisscross pattern of opposite corners: top left -> bottom right -> top right -> bottom left.

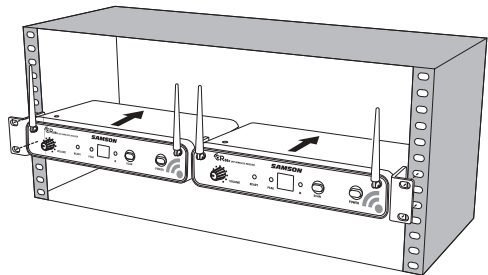

In order to mount two CR88x receivers in one rack space, the system includes a center connection piece. Slide the center connection piece into the groove of each receiver and attach the short rack ears to each receiver. Mount the receivers into the rack using the crisscross pattern described above.

# Troubleshooting

Issue	Solutions
No Audio	Make sure that the transmitter and receiver are both powered on.
	Ensure the AG8 transmitter's batteries are fully charged.
	Check that the transmitter is not muted.
	Confirm that the CR88x adapter is correctly connected and plugged into an electrical outlet.
	Turn on the CR88x receiver.
	Make sure the CR88x audio output connections are securely connected.
	Ensure that the receiver and transmitter are in line of sight with one another.
	Check the receiver and audio input device level controls.
	Ensure that the transmitter and receiver are set to the same operating channel. If unsure, reset the channel by following the steps in the "Quick Start".
Distorted Audio	The receiver output level or audio input device level may be too high.
	The input gain on the transmitter (AG8) may be too high.
Audio Dropout	The transmitter may be too far away from the receiver. Move it closer to the receiver, or reposition the antennas.
	Remove any sources that may cause RF interference such as cell phones, cordless phones, lighting equipment, computers, metal structures, etc.
Receiver will not power on	Check the adapter to ensure it is properly connected and plugged into an outlet providing power.
Transmitter will not power on	Ensure the AG8 transmitter's batteries are fully charged.
Unwanted noise or interference	If using multiple systems, make sure none of the systems are operating on the same channel. If the problem persists, change one or all of the systems channels.



# Specifications

## System

Working Range	300' (100m) line of sight
Audio Frequency Response	50 Hz - 15 kHz
T.H.D. (Overall)	<1% (@AF 1 kHz, RF 46 dBu)
Dynamic Range	>100 dB A-weighted
Signal to Noise	>90 dB
Operating Temperature	-10°C (14°F) to +60°C (+140°F)
Tone Key Frequency	35 kHz

## AG8 Guitar Transmitter

Input Connector	1/4" Plug
Input Impedance	1M $\Omega$
Input Gain Range	30dB
RF Power	5mW EIRP
Power Requirements	1 x AA (LR6)
Battery Life	5 hours
Dimensions (LxWxH)	1.17" x 1.6" x 4.5" 30mm x 40mm x 114mm (1/4" plug is mounted at 45°)
Weight	0.12lb / 50g

## CR88x Receiver

Audio Output Level - Unbalanced	+14 dBu
Audio Output Level - Balanced	+9 dBu
Audio Output Impedance - Unbalanced	810 Ohms
Audio Output Impedance - Balanced	240 Ohms
Sensitivity	-100 dBm / 30 dB sinad
Image Rejection	>50 dB
Operating Voltage	15 VDC 200mA
Dimensions (LxWxH)	8.25" x 4.9" x 1.75" 210mm x 125mm x 44mm
Weight	0.88lb / 400g

*At Samson, we are continually improving our products, therefore specifications and images are subject to change without notice.*

# Operating Bands and Frequency Ranges

Band	Frequency Range
K <sup>a</sup>	470–494 MHz
D <sup>a</sup>	542–566 MHz
IL <sup>*</sup>	794–806 MHz
B <sup>*</sup>	806–810 MHz
G <sup>*</sup>	863–865 MHz

*\* Not for use in the USA and Canada.*

## European Frequency Operation

Note: This equipment is intended for professional musical and similar applications, and may be capable of operating on some frequencies not authorized in your region. Please contact your national authority to obtain information on authorized frequencies for wireless microphone products in your region.

Band	Frequency Range	EU Country Codes	Note
K <sup>a</sup>	470–494 MHz	AT, BE, BG, CY, CZ, DK, EE, FI, FR, DE, GR, HU, IS, IE, IT, LV, LT, LU, MT, NL, NO, PL, PT, RO, SK, SI, ES, SE, CH, UK	
D <sup>**</sup>	542–566 MHz		
IL <sup>**</sup>	794–806 MHz		For use in Israel
B <sup>**</sup>	806–810 MHz		For use in Japan
G	863–865 MHz	AT, BE, BG, CY, CZ, DK, EE, FI, FR, DE, GR, HU, IS, IE, IT, LV, LT, LU, MT, NL, NO, PL, PT, RO, SK, SI, ES, SE, CH, UK	License Free

*\*\* Not for use in the EU.*

<sup>a</sup> Licensing: Note that a ministerial license to operate this equipment may be required in certain areas. Consult your national authority for possible requirements. Licensing of Samson wireless microphone equipment is the user's responsibility, and licensability depends on the user's classification and application, and on the selected frequency.



**Having Trouble with your AirLine Wireless System?  
We can help!**



**CONTACT OUR SUPPORT TEAM: [support@samsontech.com](mailto:support@samsontech.com)  
Our experts can help you resolve any issues.**

Follow us:



**@samson**



**@samsontech**



**@samson\_technologies**

---

Samson Technologies  
278-B Duffy Ave  
Hicksville, NY 11801  
Phone: 1-800-3-SAMSON  
[www.samsontech.com](http://www.samsontech.com)