



MX SERIES

USER' S MANUAL



TOPP PRO MUSIC GEAR
www.topppro.com

PROFESSIONAL SOUND MIXER
MX24.4/32.4

MAX
SERIES

Important Safety Instructions



This symbol, wherever used, alerts you to the presence of un-insulated and dangerous voltages within the product enclosure. These are voltages that may be sufficient to constitute the risk of electric shock or death.



This symbol, wherever used, alerts you to important operating and maintenance instructions.

Please read.



Protective Ground Terminal



AC mains (Alternating Current)



AC mains (Alternating Current)

ON: Denotes the product is turned on.

OFF: Denotes the product is turned off.

WARNING

Describes precautions that should be observed to prevent the possibility of death or injury to the user.



CAUTION

Describes precautions that should be observed to prevent damage to the product. Disposing of this product should not be placed in municipal waste but rather in a separate collection.

WARNING

Power Supply

Ensure that them a inssource voltage (AC outlet) matches the voltage rating of the product. Failure to do so could result in damage to the product and possibly the user. Unplug the product before electrical storms occur and when unused for long periods of time to reduce the risk of electric shock or fire.

External Connection

Always use proper ready-made insulated mains cabling (power cord). Failure to do so could result in shock/death or fire. If in doubt, seek advice from a registered electrician.

Do Not Remove Any Covers

Within the product are areas where high voltages may present. To reduce the risk of electric shock do not remove any covers unless the AC mains power cord is removed. Covers should be removed by qualified service personnel only.

No user serviceable parts inside.

Fuse

To prevent fire and damage to the product, use only the recommended fuse type as indicated in this manual. Do not short-circuit the fuse holder. Before replacing the fuse, make sure that the product is OFF and disconnected from the AC outlet.

Protective Ground

Before turning the unit ON, make sure that it is connected to Ground. This is to prevent the risk of electric shock.

Never cut internal or external Ground wires. Like wise, never remove Ground wiring from the Protective Ground Terminal.

Operating Conditions

Always install in accordance with the manufacturer's instructions.

To avoid the risk of electric shock and damage, do not subject this product to any liquid/rain or moisture.

Do not use this product when in close proximity to water.

Do not install this product near any direct heat source. Do not block areas of ventilation. Failure to do so could result in fire.

Keep product away from naked flames.

IMPORTANT SAFETY INSTRUCTIONS

Read these instructions

Follow all instructions

Keep these instructions. Do not discard.

Heed all warnings.

Only use attachments/ accessories specified by the manufacturer.

Power Cord and Plug

Do not tamper with the power cord or plug. These are designed for your safety.

Do not remove Ground connections!

If the plug does not fit your AC out let seek advice from a qualified electrician.

Protect the power cord and plug from any physical stress to avoid risk of electric shock.

Do not place heavy objects on the power cord. This could cause electric shock or fire.

Cleaning

When required, either blow off dust from the product or use a dry cloth.

Do not use any solvents such as Benzol or Alcohol.

For safety, keep product clean and free from dust.

Servicing

Refer all servicing to qualified service personnel only.

Do not perform any servicing other than those instructions contained within the User's Manual.

PORTABLE CART WARNING



Carts and stands - The component should be used only with a cart or stand that is recommended by the manufacturer. A component and cart combination should be moved with care. Quick stops, excessive force, and uneven surfaces may cause the component and cart combination to overturn.

GUARANTEE

9

Topp Pro guarantees the normal operation of the product against any defect of manufacture and/or vice of material, by the term of (12) months, counted as of the date of purchase on the part of the user, committing itself to repair or to change, to its election, without position some, any piece or component that will fail in normal conditions of use within the mentioned period.

This guarantee is valid if the original buyer will have to present /display this certificate properly sealed and signed by the selling house, accompanied by the corresponding invoice of purchase where it consisted the model and serial number of the acquired equipment.

The guarantee does not cover:

- Damages caused by the illegal use of the product, repair and / or nonauthorized modification conducted by people by Topp Pro.
- Damages caused by the connection of the equipment to other equipment different from the specified ones in the manual of use, or by bad connection to these last ones.
- Damages caused by electrical storms, blows and / or incorrect transport.
- Damages caused by excesses or falls of tension in the network or by connection to networks with a tension different from the required one by the unit.
- Damages caused by the presence of sand, acid of batteries, water, or any strange element inside the equipment.
- Deteriorations produced by the course of the time, use and/or normal wear of the unit.
- Alteraion or absence of the serial number of factory of the equipment.

The repairs could only be carried out the authorized technical service by Topp Pro, that will inform about the term and other details into the repairs to take place according to this guarantee.

Topp pro, will repair this unit in counted a term nongreater to 30 days as of the date of entrance of the unit to the Technical Service. In those cases in that due to the particularity of the spare part, outside necessary their import, the repair time and the viability of the same one will be subject to the effective norms for the import of parts, in which case one will inquire to the user about the term and possibility into repair.

With the object of its correct operation, and of the validity of this one guarantee, this product will have to be installed and to be used according to the instructions that are detailed in the manual associate or the package of the product.

This unit will be able to appear for its repair, next to the invoice of purchase (or any other comprobante where the date of purchase consists), to its authorized distributor Topp Pro or an authorized technical center on watch by Topp Pro.

Exclusion of damages:

THE RESPONSIBILITY OF TOPP PRO BY ANY DEFECTIVE PRODUCT IS LIMITED THE REPAIR OR THE REPLACEMENT OF HE HIMSELF, TO TOPP OPTION PRO. IF WE CHOSE TO REPLACE THE PRODUCT, THE REPLACEMENT CAN BE A RECONDITIONATED UNIT. TOPP PRO WILL NOT BE RESPONSIBLE BY THE DAMAGES BASED ON THE LOST, INCONVENIENCE, LOSS OF USE, BENEFITS, LOST SAVINGS, BY THE DAMAGE TO OTHER EQUIPMENT OR OTHER ARTICLES IN THE USE SITE, OR BY ANY OTHER DAMAGE IF HE IS FORTUITOUS, CONSEQUENT OR OF ANOTHER TYPE, ALTHOUGH TOPP PRO HAS BEEN NOTICED OF THE POSSIBILITY OF SUCH DAMAGES.

Some states do not allow to exclusion or the limitation to the fortuitous or consequent damages, so the aforesaid limitation can not be applied to you.

This guarantee gives specific legal rights him, you can also have other right that varies of state to state.

8

TECHNICAL SPECIFICATION

Input	
Input impedance	Mic 2 kohm Balanced Line 10kohm Balanced
Input gain	Mic continuously variable from 0dB to +50dB Line-Mono Channel continuously variable from -15dBto+35dB Line-Stereo Channel continuously variable from -20dB to+20dB
Maximum input level	Mic +22dBu Line(Mono Channel)+22dBu Line(Stereo Channel)+22dBu
Insert send impedance	120 ohm Unbalanced
Insert send level/Max	-10dBu/+22dBu
Insert return impedance	10 kohm Unbalanced
Insert return level/Max.	-10dBu/+22dBu
CMR at 1 kHz Line(20Hz-20kHz)	>60dB
Frequency Response	Mic to Mix 20Hz-20kHz +/-3dB
Signal/Noise Ratio(20Hz-20kHz)	Mic EIN ref.150ohms - 117dBu
System Noise(20Hz-20kHz)	
Summing noise	-90dBu(24channels routed with faders down)
Line to Mix Noise	-86dBu(24 channels routed at 0dB, pan center)
Distortion at 1 kHz	Mic to insert(+30dB unity gain, +20dBu output(<0.009% Mix to Mix(+30dB unity gain, +20dBu output)Typ 0.03%
Crosstalk at 1 kHz	Channel to channel > -80dB Mix to Mix > -80dB Channel to Mix > -80dB
Fader Attenuation	>100dB
Output(nominal signal level mic-50dBu to 0dBu -Line 0dBu)	
Output impedance	All line outputs 120 ohm Balanced
Insert send impedance	120 ohm Unbalanced
Insert send level/max	+22dBu
Insert return impedance	10 kohm Unbalanced
Insert return level/max	+22dBu
Maximum output level master outputs on XLR	+28dBu
All outputs on 1/4" jacks	+22dBu
Headphones	+22dBu/600 ohm
Main Mix Section	
HI-shelving	+/-15dB @12 kHz
MID HI-bell(STEREO)	+/-12dB @3 kHz
MID-bell(MONO)	+/-12dB frequency range 100Hz - 8KHz
MID LOW-bell(STEREO)	+/-12dB @ 500hz
Bass-shelving	+/-15dB @ 80Hz
Hi Pass Filter Slope	-18dB/Oct. @75Hz
Power Supply	
USA/Canada	100-120VAC~60Hz
Europe	210-240VAC~50Hz
U. K./Australia	240VAC~50Hz

TABLE OF CONTENTS

1. INTRODUCTION.....	1
2. FEATURES.....	1
3. USEFUL DATA.....	1
4. CONTROL ELEMENTS.....	3
5. OPTIONAL MODULES	9
6. INSTALLATION AND CONNECTIONS.....	16
7. BLOCK DIAGRAM	18
8. TECHNICAL SPECIFICATION.....	19
9. GUARANTEE	20

Don't forget to visit our website at www.topppro.com for more information about this and other **Topp Pro** products.

1

INTRODUCTION

Thank you for purchasing the MX series mixing console. MX24.4/32.4 are available for 24/32 channels. Your MX Series is a remarkable compact mixer that doesn't find many equals in the market today. With 18/26 MIC and 6 Stereo Line-level inputs for serious live performances. Your MX Series also provides: a 24-bit digital multi-effect with 100 Factory Presets; 9-Band EQ and Three kinds of Mp3 modules for options. There is a 2-band fixed and 2-band sweep EQ on mono channels, 4-band fixed EQ on stereo channels. Use it for large GIGs and for fixed PA installation.

Enjoy your MX Series and make sure to read this Manual carefully before Operation!
Thank you again for making the right choice in purchasing the TOPP PRO MUSIC GEAR.

2

FEATURES

- * 18/26 MIC inputs with gold plated XLR and balanced LINE inputs
- * 6 Stereo input channels with balanced TRS jacks
- * Ultra-low noise discrete MIC preamps with +48 V Phantom Power
- * Extremely high headroom offering more dynamic range
- * Each input channel with Mute, SOLO function, overload LEDs & low cut filters
- * MIC channel with LOW CUT filters and PHASE
- * 6 AUX sends per channel, AUX1-2/AUX3-4/AUX5-6 with PRE/POST faders switchable
- * 4-band EQ with two swept mid on microphone channels
- * 4-band fixed EQ on stereo channels
- * SUB1-2, SUB3-4, MAIN L-R, CENTER signal assignment switch
- * 100mm high precision faders
- * Channel inserts and direct outputs on each mono channel plus main mix insert for flexible connection of outboard equipment
- * MATRIX A & B for (SUB1-SUB2)(SUB3-SUB4)(L-R)(CENTER)
- * Control room/phones matrix
- * 2-TRACK IN assignable to main mix, control room/headphone outputs
- * Fully assignable Talkback sections
- * With USB port, record from SUB1-2 or MAIN OUT and play to CH23-24 or MAIN BUS
- * Option DSP effect with 100effects
- * Option Stereo 9-band graphic EQ for MAIN
- * Option 4 MP3 PLAYER modules

3

USEFUL DATA

Please write your serial number here for future reference.

Serial Number:

Data of Purchase:

Purchased at:

BLOCK DIAGRAM

7

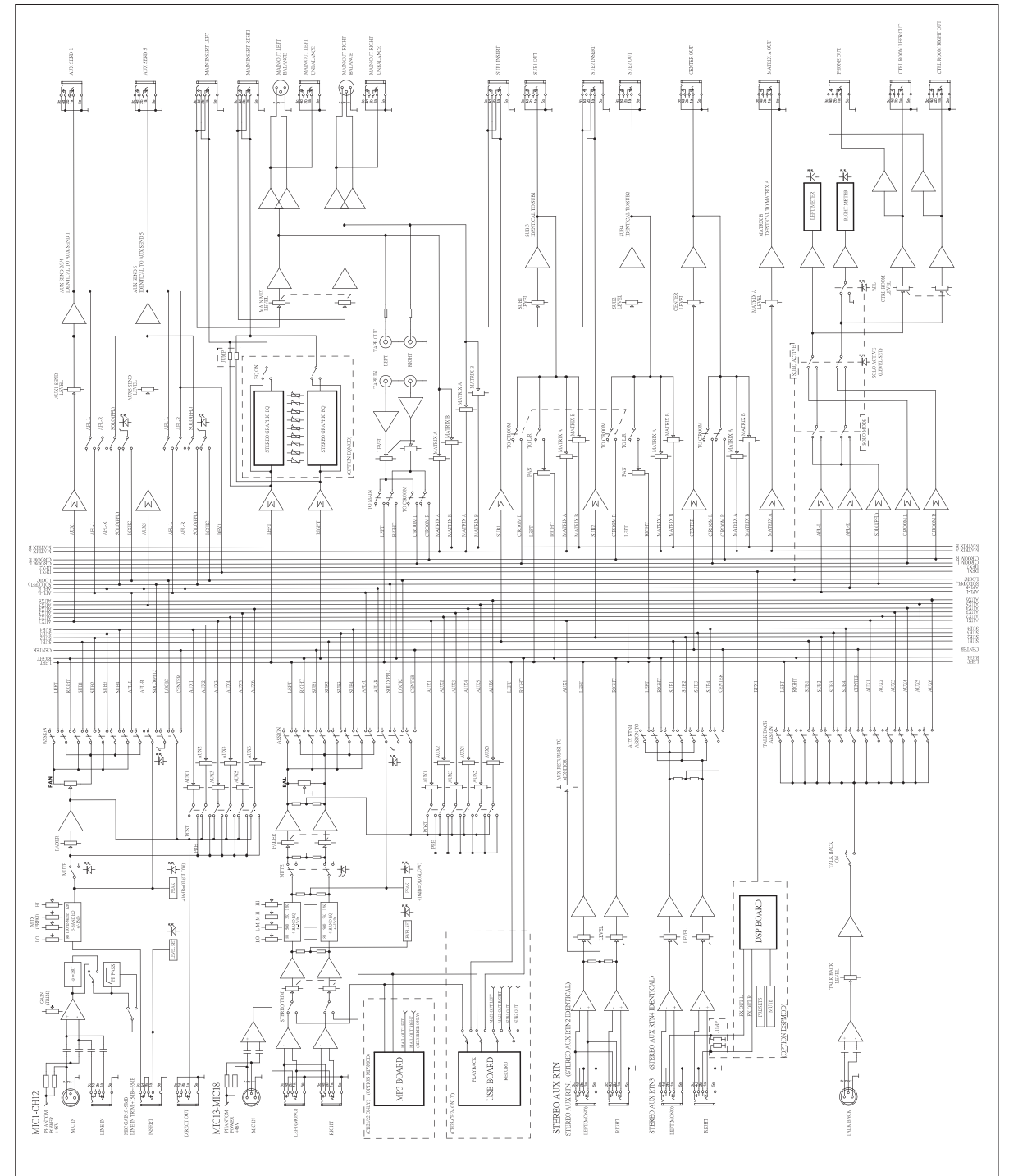

6

INSTALLATION AND CONNECTIONS

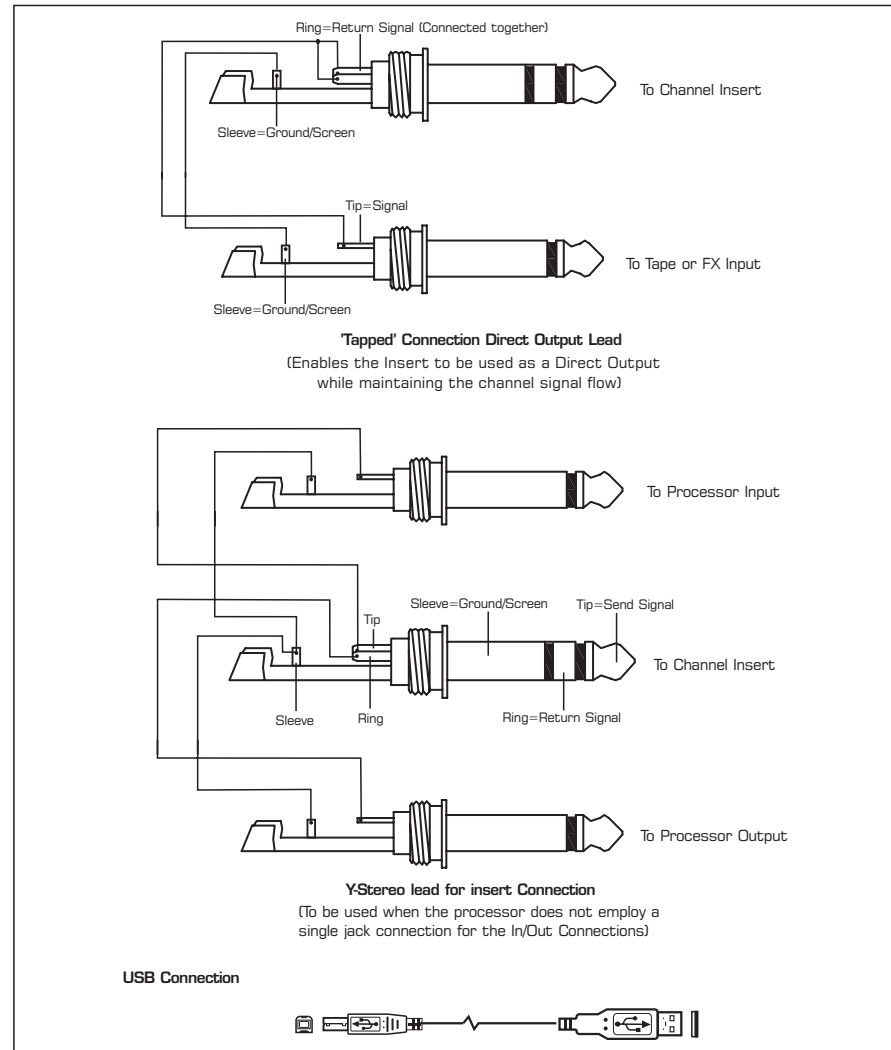
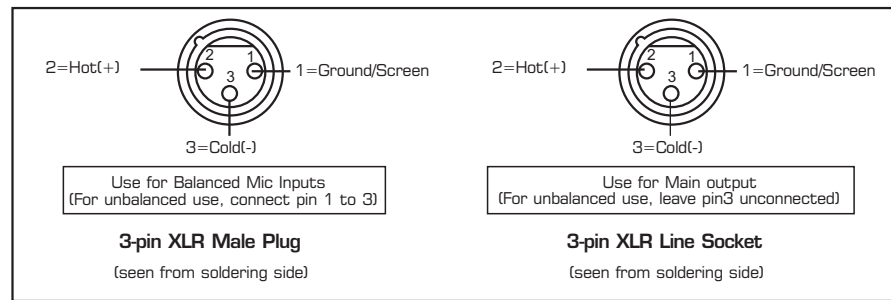
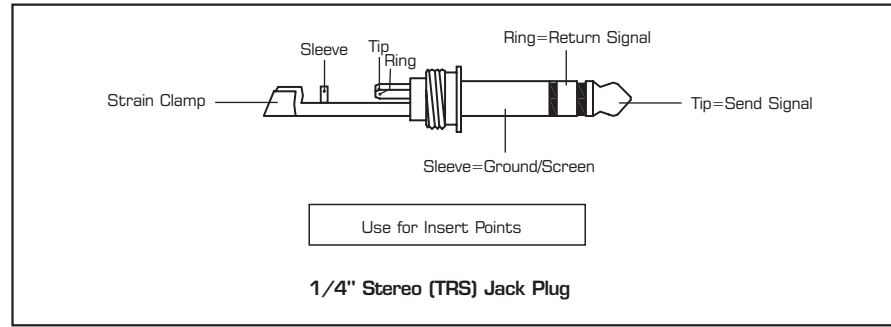

HOOKUP DIAGRAM

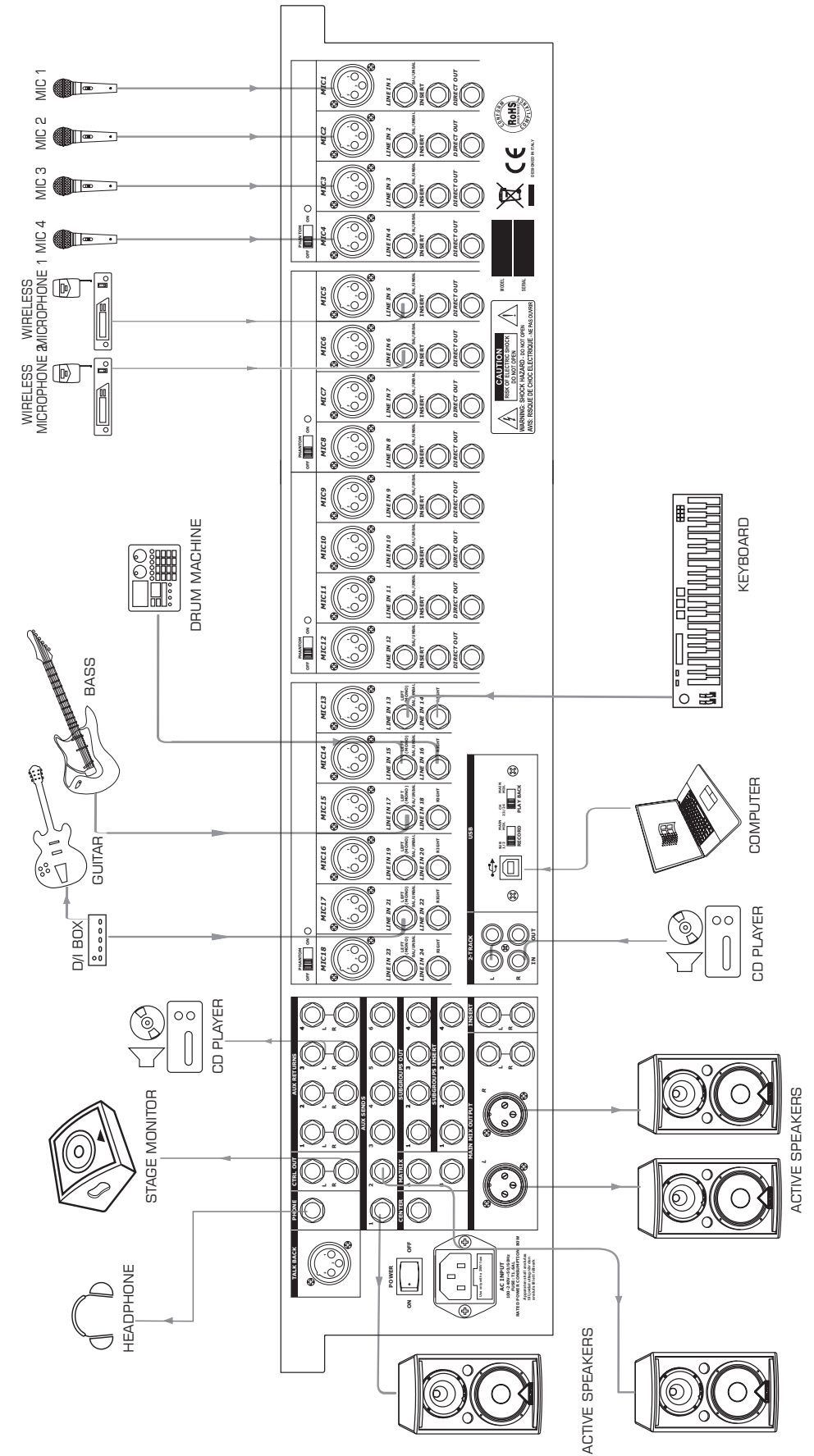

CONTROL ELEMENTS

FRONT PANEL

1- PHASE SWITCH(EXCEPT FOR CH21/22, 23/24)

This switch allows the user to invert by 180° the signal. This switch is very useful in a lot of circumstances, in particular when several microphones are very close (e.g. Drum kit, brasses, chorus, etc.) And the sound engineers notices interferences between microphones that can not be solved moving the microphones.

2- LOW-CUT BUTTON

By pressing this button, you will activate a 75Hz low frequency filter with a slope of 18 dB per octave. You can use this facility to reduce the hum noise infected by the mains power supply, or the stage rumble while using a microphone.

3- TRIM

The TRIM control is applied in the mono MIC and stereo input channels. It provides with 2 different indications: One is for the MIC and the other for LINE levels. When you use a microphone, you shall read the MIC ring (0~50 for mono MIC input, 0~40 for stereo channels); when you use a line level instrument, you shall read the LINE ring (+15~-35 dB for mono MIC input, +20 ~-20 dB for stereo channels). For optimum operation, you shall set this control in a way that the PEAK LED(15) blinks only occasionally in order to avoid distortion on the input channel.

4- LEVEL SET LED

This LED will help you to detect the input level immediately. In this case, the research of the fault will become much faster!

5- LINE/MP3 BUTTON(CH 21/22)

By pressing this button, it will switch to the MP3 mode, the MP3 signal can be sent to this channel. By releasing this button, the LINE IN inputs signal will send to the input channel(You have to install the MP3 MODULE first).

6- LINE/USB BUTTON(CH 23/24)

By pressing this button, it will switch to the USB mode, then the USB signal can be sent to this channel; by releasing this button, the LINE IN inputs signal will send to the input channels.

EQUALISER

There are 2-band fixed and 2-band sweep EQ on mono channels: HI, MID-HI, MID-LOW and LOW. There are 4-band fixed EQ on the stereo channel HI, HI-MID, MID-LOW and LOW band.

7- HIGH

If you turn this control up, you will boost all the frequencies above 12 kHz (shelving filter). You will add transparency to vocals and guitar and also make cymbals crispier. Turn the control down to cut all frequencies above 12 kHz. In such way, you can reduce sibilances of human voice or reduce the hiss of a Tape player.

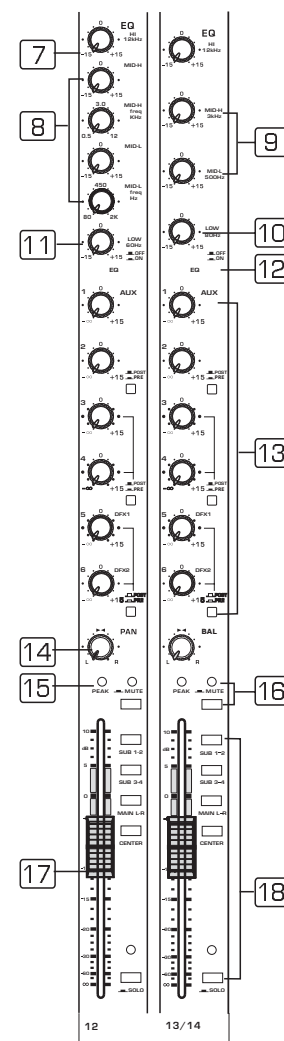
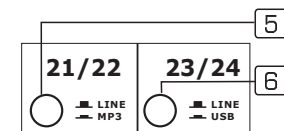
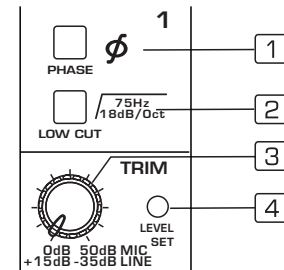

INSTALLATION AND CONNECTIONS

Ok, you have got to this point and you are now in the position to successfully operate your MX24.4/32.4. However, we advise you to read the following section carefully to be the real master of your own mix. Not paying enough attention to the input signal level, the routing of the signal and the assignment of the signal will result in unwanted distortion, a corrupted signal or no sound at all. So you should follow this procedure for every single channel:

1. Turn down all Input and output gain controls.
2. Connect phantom powered microphones before switching on the +48 Volt phantom power switch.
3. Set the output level of your MX24.4/32.4 mixer or the connected power amplifier at no more than 75%.
4. Now, set the CONTROL ROOM/PHONES level at no more than 50%. In this way, you will be able to hear later what you are doing connecting a pair of headphones or a pair of powered studio monitor speakers.
5. Position EQ controls on middle position.
6. Position panoramic (PAN/BAL) control on center position.
7. With a pair of headphone or studio monitor speakers are connected, apply a Line Level input signal so that the PEAK LED does not light up.
8. Increase the input gain properly for maintaining the good headroom and ideal dynamic range.
9. Depending on the actual application, turn slowly the input and output level controls for obtaining the maximum gain before distortion.
10. Now repeat the same sequence for all input channels. The main LED meter could move up into the red section. In this case you can adjust the overall output level through the main mix control.

Audio Connections

You can connect unbalanced equipment to balanced inputs and outputs. Simply follow these schematics.

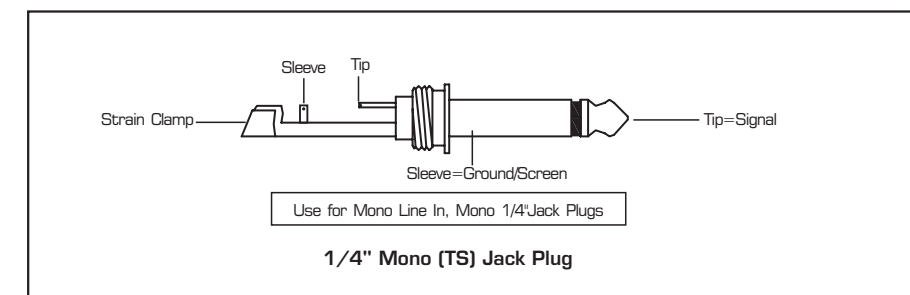
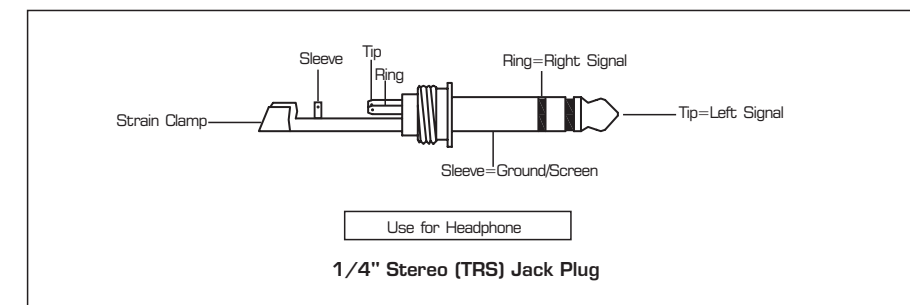

OPTIONAL MODULES

6-▶|| PLAY/PAUSE

In play state, press ▶|| PLAY/PAUSE key to pause the player. In pause state, press ▶|| PLAY/PAUSE key to start playing.

7-↺ RPT

Press this key, the player will change between the following four modes:

REP ALL means to repeat all tracks in the memory, mark on the screen is 

REP1 means to repeat one track, the mark on the screen is 

Play in order means to play the tracks according to the order, the mark on the screen is blank.

Random play means to play the tracks at random, the mark on the screen is A.

8-POWER(Push & Hold)

When the unit is off, press this key and hold for about 2 or 3 seconds to turn on the power supply of the player. Repeat the above operation, you can turn off the power supply of the player.

9- DISPLAY

All the USB player information are monitored through this sexy & magic display.

USB Module Installation

-No selective mode

At normal state, there is no selective mode on the front panel, only a piece of panel without function.

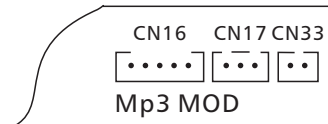

-USB PLAYER selective mode

Please connect the 5PIN row-wire on the USB module to the CN16 header and 2 PIN row-wire to CN 33header on front panel. For Recording module, you also need to connect the 3 PIN row-wire to CN 17header to start recording function. Then fix the USB module on front panel with two screws.

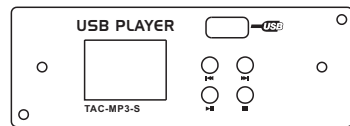

A) Song Module

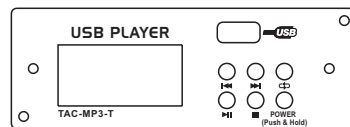
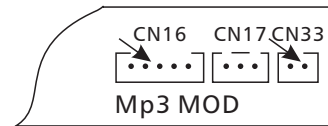

B) Track Module

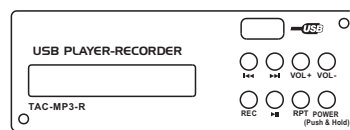
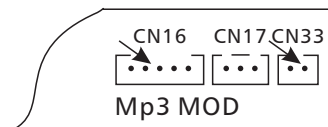

C) Recording Module

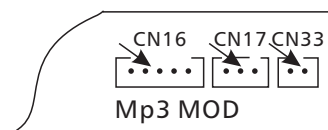

CONTROL ELEMENTS

8- MID-HI(0.5-12K) & MID-LOW(80-2K)

This is a peaking filter and it will boost/cut frequencies from 100 Hz to 8 kHz depending on the position of the MID freq control. This control will affect especially upper male and lower female vocal ranges and also the harmonics of most musical instruments.

9- HI-MID

This control gives you up to 15 dB boost or cut at 3 kHz. It is useful for controlling voice. It can accurately polish your performance via adjusting this knob.

10- MID-LOW

This control gives you up to 15 dB boost or cut at 500 Hz.

11- LOW

If you turn this control up, you will boost all frequencies below 80 Hz. You will give more punch to bass drum and bass guitar and make the vocalist more "macho". Turn it down, you will cut all the frequencies below 80 Hz. In this way, you can avoid low frequency vibrations and resonance thus preserving the life of your woofers.

12- EQ SWITCH

This switch allows the user to use the EQ Section in signal path. Of course it can be used to make A/B comparisons between equalized signal and not equalized signal. It also can be used to apply equalization at a certain point of the show, excluding it when it's not necessary.

13-AUX SENDS LEVEL CONTROL

These six controls are used to adjust the level of the respective signal sent to AUX bus, AUX1,AUX2, AUX3,AUX4,AUX5,AUX6 can be switched to PRE/POST-FADER via the PRE/POST button, so, generally, they can be used for monitor application and effects & sound processors input. In this typical compact unit, excluding sending out the signal directly to the external effect or processor equipment, AUX SEND 5&6 can also be assigned to the internal onboard effect module.

14-PAN/BAL CONTROL

Abbreviation of PANORAMA control for mono channels, or the stereo channels, always says, BALANCE control. Keep this control in center position, then the signal will be positioned in the middle of stage.

15-PEAK LED

Inside your MX24.4/32.4, the audio signal is monitored in several different stages and then sent to the PEAK LED. When the LED is red illuminated, it warns you that you are reaching signal saturation and possible distortion, then you should reduce the input level for avoiding distortion.

16-MUTE BUTTON & LED

Each channel is equipped with a MUTE button. Pressing this button is equal to turning the fader down, which can mute the corresponding channel output except for the channel INSERT send and SOLO (in PFL mode). And the MUTE LED will illuminate.

17-FADER

This fader will adjust the overall level of this channel and set the amount of signal send to the main output.

18-ASSIGNMENT Controls

Each channel provides five push-buttons: SUB1-2, SUB3-4, MAIN L-R, CENTER and SOLO. Pressing the SOLO button, the corresponding SOLO LED will illuminate and the SOLO signal will replace other signals send to the Headphone/Control Room and Meters. Usually use the SOLO function in live work to preview channels before they are let into the mix.

CONTROL ELEMENTS

It is useful to set an instrument's input level and EQ, and you can also solo any channel that you want to. The SOLO switch never affects any mix other than the Control Room. The other four buttons can be considered as signal assignment switches.

Pressing the SUB1-2 will assign the channel signal to Subgroup1/2, you can depend on the PAN switch to adjust the amount of channel signal sent to the SUB1 versus SUB2, when turns the PAN to completely left, then the signal can be only controlled by Subgroup1 and vice versa. In the same way, pressing the SUB3-4 or MAIN L/R or CENTER will assign the channel signal to Subgroup 3/4 or MAIN MIX L/R, and will also be affected by PAN.

19- MASTER AUX SENDS CONTROLS

These six controls are used to determine the master AUX SEND levels, which can be varied from $-\infty$ to +15 dB. When the external effect units which have no input gain control were connected to mixer, you can get a further +15 dB gain available from these Aux Send outputs.

20- SOLO Button

The function of these SOLO buttons are the same as the channel SOLO button, they can also be affected by the SOLO MODE switch. Press the SOLO button, the corresponding AUX send will be routed to the Ctrl Room/Phones outputs and Meters display.

21- MASTER STEREO AUX RETURNS CONTROLS

These four controls set the level of effects that received from the stereo AUX RETURN connectors, which can be varied from $-\infty$ to +15 dB. They are used to provide the further gain for low level effects.

22- TO AUX SEND1/2

The both rotary knobs assign the AUX RETURN signals to their respective AUX SEND outputs: The "TO AUX SEND1" assign the signal from AUX RETURN1 to AUX SEND1 bus, and "TO AUX SEND2" assign the signal from AUX RETURN2 to AUX SEND2 bus. The adjustable range goes from $-\infty$ to +15 dB.

23- SUB1-2/SUB3-4/MAIN L-R/CENTER BUTTONS

These two groups of buttons are configured for AUX RETURN3/4, they can be regarded as the signal assignment switches. For example, When engaging the SUB1-2, the stereo signal from AUX RETURN3 will be assigned to Sub-group1/2; In the same way, SUB3-4 for Subgroup3/4, MAIN L-R for MAIN L-R buses.

24- MATRIX A&B

These controls will allow the sound engineer to address SOURCES SIGNAL to SUB1, SUB2, SUB3, SUB4, MAIN L, MAIN R, CENTER.

25- 2TK LEVEL & TO MIX BUTTON

By rotate the knobs, you can adjust the stereo signals level of 2TK input and engaging the switch allows you to combine the 2-Track output with the Main Mix and C.Room. In other words, feeds the 2-Track In signals into Main L/R output.

26- SUBGROUPS ASSIGN TO MAIN MIX

Through these switches, you can operate the subgroup faders as a master control for assigning the subgroups to MAIN MIX.

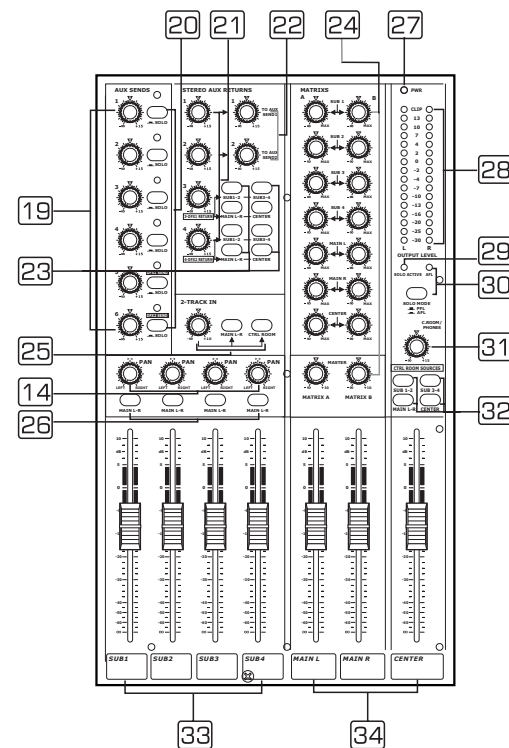

OPTIONAL MODULES

5- ►|| PLAY/PAUSE

In play state, press ►|| PLAY/PAUSE key to pause the player. In pause state, press ►|| PLAY/PAUSE key to start playing.

6- ■ STOP

In play state, press this key to stop playing and all the songs in USB memory will appear on the display; In stop state, press ■ STOP/◀◀ PRE/▶▶ NEXT keys again to go to first song and the player will keep in pause state, then press ►|| PLAY/PAUSE key to play the song.

7- POWER(Push & Hold)

When the unit is off, press this key and hold for about 2 or 3 seconds to turn on the power supply of player. Repeat the above operation, you can turn off the power supply of the player.

8- DISPLAY:

All MP3 player information are monitored via this sexy & magic display.

NOTE: basic interface instruction

When the player isn't connected to a USB memory equipment, the interface is as follows:



When the player is searching for USB tracks, the interface is as follows:



When the player is in pause state, the interface is as follows:



When the player is in use, the interface is as follows:



Option Three - Recording Module

The file system of USB memory for USB players is FAT16 and FAT32, and these players can only decode MP3. It has 7 rank subordinate folders at most.

1- USB PORT

For connecting with USB memory.

2- ◀◀ PRE

In pause state, press this key, it will go to previous track and keep in pause state. In play state, press this key, it will go to the previous track and start playing.

3- ▶▶ NEXT

In pause state, press this key, it will go to next track and keep in pause state. In play state, press this key, it will go to the next track and start playing.

4- VOL-/VOL+

Press VOL-/VOL+ key to increase or decrease volume during Power on state. The default factory setting is 10.

5- REC

In power on state, press this key, it will go to the recording preparation state. Press REC again to start recording. Any other operations are not available in recording state until press POWER to stop recording; if the word Err appears during recording, press POWER to stop.

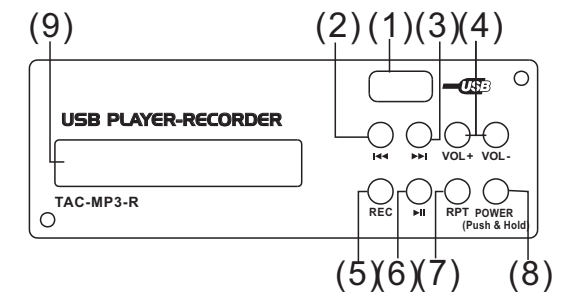

OPTIONAL MODULES

4-"Program" mode

- a) In Fig 2, select "Program" to enter into the following interface:" Play list Set": Set the playing list."Playing List": Play list. Press◀◀PRE/▶▶NEXT key to select, press ■ STOP key to return the Fig2 interface.
- b) After entering into the "Play List Set", the display will show as Fig3. Selecting the desired folder, the display will show the following interface. The display will show all the MP 3 files, the selected song will be inserted into the playing list and a mark will appear. Press again you're going to delete the song from the playing list, and the mark will disappear. Press the ■ STOP key, you will return to Fig 2 interface. The playing list can accept up to 20 songs, and it will display the list according to song insert order.
- c) The display will show the following interface. Press the ◀◀ PRE /▶▶ NEXT key, you can select the starting song, then press the ▶▶ PLAY/PAUSE key, the selected song playback will start. Press ▶▶ PLAY/PAUSE key again, or press ■ STOP key, the playback will stop. Press ▶▶ PLAY/PAUSE key again, or press ■ STOP key, the playback will start again from the same point. Twice press ■ STOP, the USB player will return to Fig 3 interface.

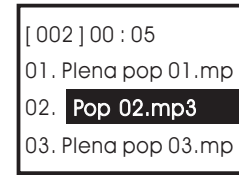

Fig 4

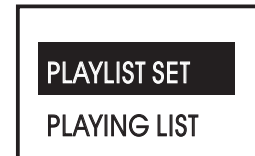

Fig 5

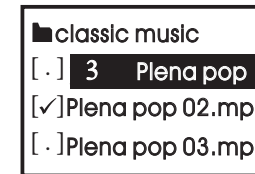

Fig 6

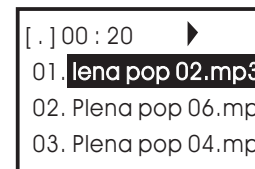

Fig 7

5-Folder List:

See the Fig 3, the display shows MP3 files folders names. Use ◀◀PRE/▶▶ NEXT key to scan, press ▶▶ PLAY/PAUSE key, you'll enter into corresponding folder. In order to return to Fig5 interface, you just need to press the ■ STOP key.

Option Two - Track Module

The file system of USB memory for USB players is FAT16 and FAT32, and these players can only decode Mp3. It has 7 rank subordinate folders at most.

1- USB PORT

For connecting with USB memory.

2- ◀◀ PRE

In pause state, press this key, it will go to previous track and keep in pause state. In play state, press this key, it will go to the previous track & start playing.

3- ▶▶ NEXT

In pause state, press this key, it will go to next track and keep in pause state. In play state, press this key, it will go to the next track and start playing.

4- ⇄RPT

Press this key, the player will change between the following four modes:

REP ALL means to repeat all tracks in the memory, mark on the screen is

REP1 means to repeat one track, the mark on the screen is

Play in order means to play the tracks according to the order, the mark on the screen is blank.

Random play means to play the tracks at random, the mark on the screen is A.

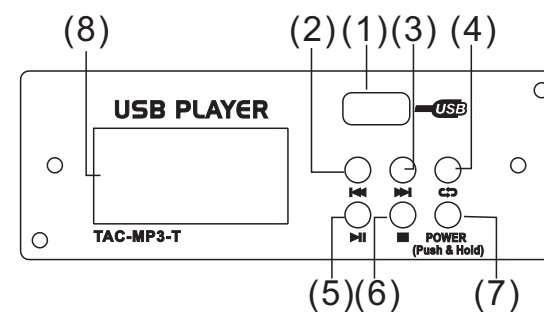

CONTROL ELEMENTS

27- POWER LED

The LED indicates when the power is ON.

28- LED METER

The stereo 16-segment LED Meter will indicate the signal level send to the Ctrl Room and Phones outputs.

29- SOLO ACTIVE/AFL

This LED indicates that the one or more SOLO button have been activated. when this LED is on, the METERS indicates the level of the signal of the selected channel or mixer section in AFL mode.

30- SOLO MODE BUTTON

This button provides two modes: up for PFL (Pre-Fader-Listen) mode, down for AFL (After-Fader-Listen) mode. Engage the button, the soloed signal will output after the Level control, otherwise, release the button will output the soloed signal before the Level control.

※NOTE: The SOLO function can never affect the mix at main recording output, and also can't be affected by channel's MUTE switch.

31- PHONES/CTRL ROOM CONTROL

Rotate this knob to adjust the stereo level of CTRL ROOM & PHONES outputs separately, which can be varied from -∞ to MAX.

32- CONTROL ROOM SOURCE

You can choose to monitor any combination of MAIN L-R, SUB1-2, SUB 3-4 and CENTER via these Matrix switches. Engaging these switches, the stereo signals will be delivered to the Phones, Control Room and Meters display.

※NOTE: When any SOLO switch was engaged, the SOLO signal will replace other signals, and also be sent to the Control Room, Phones and Meters.

33- SUBGROUPS FADER

These faders are used to control the levels of the signal send to the SUB-GROUPS OUT, the adjustable range goes from -∞ to +10 dB. Any channel that is assigned to the subgroups, not muted and not turned down will be assigned to the SUB OUTS.

34- MAIN MIX LEVEL FADER

This fader sets the amount of signal send either to the Main Mix Output or to the Tape Output.

35- TALKBACK LEVEL

This is the main level control for the talkback section.

36- TALKBACK SWITCH

This switch activates and sends the talkback signal to its selected outputs.

37- TALKBACK SIGNAL ASSIGNMENT SWITCHES

AUX1-2,AUX3-4, AUX5-6 switches will allow the sound engineer to address the SOURCES signal to Auxiliaries. In this way you can send, e.g.,The Talkback signal to all stage monitors to communicate directly with performers while audience will hear

SUB1-2,SUB3-4,MAIN L-R, CENTER switches allow the sound engineer to assign the talkback signal to the audio path he wants to. The odd/even numbered switches are used to send the signal to subgroups (then you can send their signal to L/R outs) while L/R switch sends the signal directly to Main Mix.

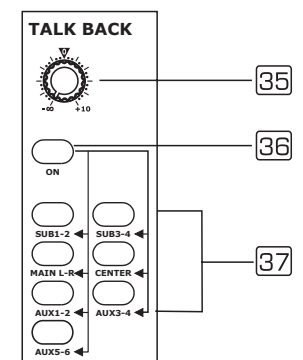

CONTROL ELEMENTS

REAR PANEL

1- +48 V PHANTOM POWER SWITCH

It is available only to the XLR MIC sockets. Never plug in a microphone when phantom power is already on. Before turning phantom power on, make sure that all faders are totally down. In this way, you will protect your stage monitors and main loudspeakers.

Note: this phantom power switch will control the adjacent four MIC channels, such as from CH1-CH4.

2- MONO MIC/LINE CHANNELS

Your MX24.4/32.4 is equipped with 18/26 low-noise microphone pre-amplifier with optional phantom power, 50 dB of Gain and over 115 dB of S/N ratio. You can connect almost any type of microphone. Dynamic microphones do not need phantom power. Use phantom power only with condenser microphones but make sure that the phantom power button is disengaged before connecting the microphone. Phantom power may damage your dynamic microphones, so make sure to read the MIC instructions manual before engaging phantom power. Use switch (1) to activate/deactivate phantom power. These channels are also equipped with 1/4" TRS balanced/unbalanced LINE-IN plugs to connect line-level instruments such as keyboards, drum machines and effect devices.

3- MONO CHANNEL INSERT

This is where you connect external sound processors such as compressor-limiter, equalizers, etc.. MONO channel inserts are available for mono channels 1-12 for MX24.4(mono channels 1-12 and 25-32 for MX32.4)

4- DIRECT OUTS

Each Mono MIC/LINE Channel is equipped with the 1/4" phone jack for directing output. These jacks are used to send the signal from the channel path to external device for recording function etc..

5- STEREO INPUTS

These are channels 13 to 24. They are organised in stereo pair & provided with XLR sockets and 1/4" TRS phone jacks. If you connect only the left jack, the input will operate in mono mode, that is the mono signal will appear on both input channels. You can use these inputs with a stereo keyboard, drum machine, etc.

6- 2-TRACK (TAPE IN)

Use the tape input if you wish to listen to your mix from a Tape Recorder or DAT.

7- 2-TRACK (TAPE OUT)

These RCA jacks will route the main mix into a tape recorder.

8- USB PORT

This USB port is used to connect the unit to PC with a transmission line. When it is in RECORD mode, it can connect with the SUB1-2 or MAIN MIX output when in the PLAYBACK mode, it can connect with CH23/24 or MAIN MIX.

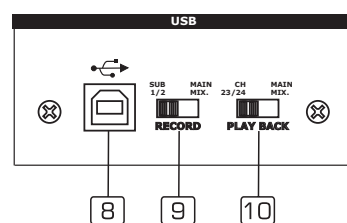
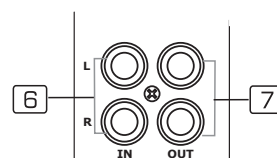
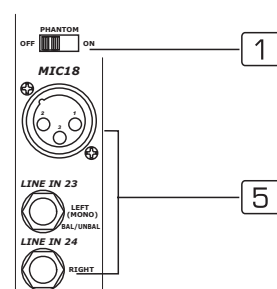
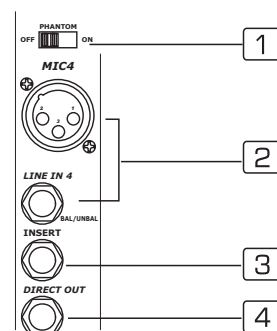

OPTIONAL MODULES

Optional USB Players Modules Section

This section can be selected and installed according to user's requirement. Please see installation procedure .(USB Module Installation)

Option One - Song Module

The file system of USB memory for USB players is FAT16 and FAT32, and these players can only decode Mp3. It has 7 rank subordinate folders at most.

- 1- USB port: For connecting with USB memory equipment.
- 2- ⏮ PRE: In pause state, press this key, it will go to the previous song and still keep in pause state; In play state, press this key, it will go to the previous song and start playing; Furthermore, press this key and hold for a few seconds to decrease the volume.
- 3- ⏭ NEXT: In pause state, press this key it will go to the next song and still keep in pause state; In play state, press this key it will go to the next song and start playing; Furthermore press this key and hold for a few seconds to increase the volume.
- 4- ⏸ PLAY/PAUSE: In play state, press this key to pause the player; In pause state, press to start playing.
- 5- ■ STOP: In play state, press this key to stop playing and all the songs in USB memory will appear on the display ; In stop state, press ■ STOP/⏮ PRE/⏭ NEXT keys again to go to first song and the player will keep in pause state, then press ⏸ PLAY/ PAUSE key to play the song.
- 6- DISPLAY: All USB player information are monitored through this sexy & magic display.

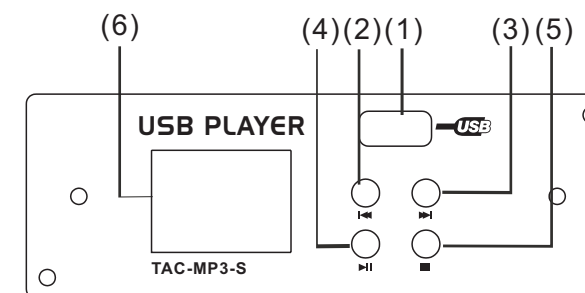

Operation Instruction for Song Module

- 1- When no USB key inserted, the display will show as Fig. 1
- 2- Inserted the USB key, the USB player starts to search the songs in USB key, and the display shows "Searching". At the end of the search, the display will show as Fig. 2. Using ⏮ PRE/⏭ NEXT keys, you can select one of following three menu options ("Playing", "Program" and "Folder List"). Press Playing, the unit will enter into the corresponding operation mode.



Fig 1



Fig 2

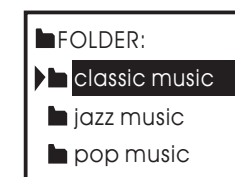

Fig 3

3- "Playing" mode - single song play

- a). In Fig 2, selecting the Playing mode to recall following interface. This display shows the name of all the folders containing MP 3 files. Using the ⏮ PRE/⏭ NEXT keys, you can scan the folders, then press ⏸ PLAY/PAUSE key, you will open corresponding folders. Press ■ STOP to return to Fig 2 interface.
- b). After opening the folder, the display will show as Fig 3. This display shows MP 3 file list, and scrolling list using ⏮ PRE/⏭ NEXT keys you can choose the desired song. Press the ⏸ PLAY/PAUSE key, the selected song playback will start. In order to stop playback, you just need to press the ■ stop key. Then, if you press the ⏸ PLAY/PAUSE key, the song playback will start from the pause point, if you press again the ■ stop key, the system will return to Fig 3 interface.

OPTIONAL MODULES

function

1- DISPLAY

It displays the selected preset.

2- PRESETS SELECTOR

Adjust this knob to select the right effect you wish to perform. There are totally 100 options for you: Echo, Vocal, Plate and versatile two-effect combination. When you are satisfied the right preset, please push this knob to store this preset you want.

3- DSP MUTE Switch & PEAK LED

This switch is used to activate/deactivate the effect facility. This LED lights up when the input signal is too strong. In case of the digital effect module being muted, this LED also lights up.

Preset list for DSP effect

NO.	Preset	Description	Parameter
00~09	Echo	Reproduce the sound in input on the output after a lapse of time or delay.	Delay Time : 145~205ms
10~19	Echo+Verb	Echo with Room effect.	Delay Time : 208~650ms Decay time : 1.7~2.1s
20~29	Tremolo	Amplitude modulation of the signal.	Rate : 0.6 Hz~5 Hz
30~39	Plate	Simulate the transducers sound like classic bright vocal plate.	Decay time:0.9s~3.6s
40~49	Leslie	Recreate the illusion of more than one instrument from a single instrument sound.	Rate : 0.92Hz ~1.72Hz
50~59	Vocal	Simulate a small space with slight decay time.	Rev. decay time: 0.8~0.9s Pre-delay: 0~45ms
60~69	Rotary	Simulate the sound effect achieved by rotating horn speakers and a bass cylinder.	Modulation depth : 20%~80%
70~79	Small Room	Simulate a bright studio room.	Decay time : 0.7~2.1s Pre-delay : 20~45ms
80~89	Flanger+Verb	Simulate to play with another person carrying out same the notes on the same instrument and reverb.	Decay time : 1.5~2.9s Rate : 0.8Hz ~2.52Hz
90~99	Large Hall	Simulate a large acoustic space of the sound. Decay time : 3.6~5.4s	Pre-delay : 23~55ms

CONTROL ELEMENTS

9- USB RECORD SWITCH

You can select SUB1/2 or MAIN MIX track to input the record signal to PC.

10- USB PLAYBACK SWITCH

You can select Ch23/24 or MAIN MIX track to output audio signal from PC.

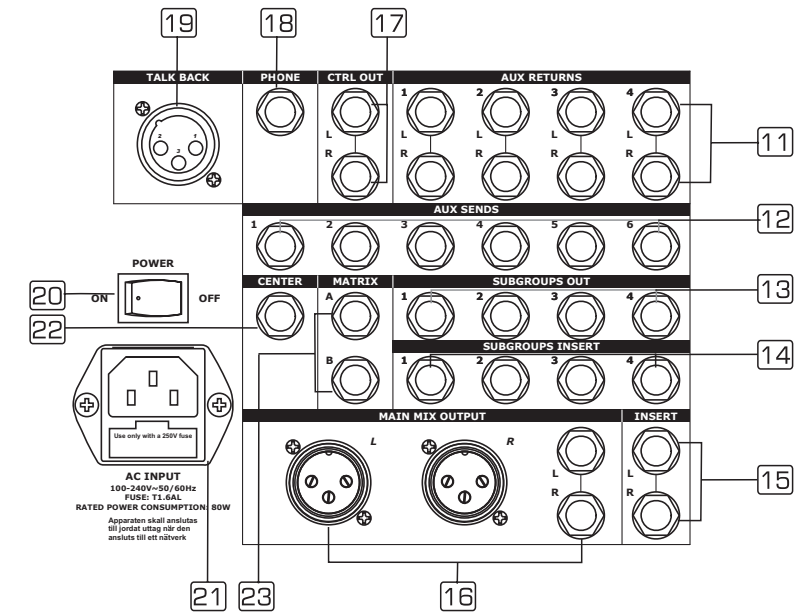

11- AUX RETURNS JACKS

Use these stereo 1/4" phone jacks to return the stereo signal of an effect unit to the Main Mix. Alternatively you can also use them as an extra auxiliary input via using the AUX RETURN level control as volume control. The signal will be sent directly to MAIN MIX control.

12- AUX SENDS

These 1/4" phone jacks are used to send out the signal from the AUX Bus to external devices such as effect units and/or stage monitors.

13- SUBGROUPS OUT JACKS

These 1/4" phone jacks are used to connect the inputs of deck or secondary in a complicated PA live sound system. You will find it is the best tool when you operate the SUBGROUPS OUT.

14- SUBGROUPS INSERTS

These 1/4" phone jacks are insert points. They are used to connect processors, such as compressor, limiter, EQ, etc. When insert external processor into these jacks, the subgroup stereo signal will be taken out, then returned to before subgroups fader. Of course, these used jacks must be stereo (Tip Send/Ring Return)

15- MAIN INSERT

These two 1/4" phone jacks are stereo insert points and used to connect processors such as compressors, equalisers etc. When insert an external processor into the jack, the Main stereo signal will be taken out after the EQ and returned into the MAIN MIX output before the MAIN MIX fader.

16- MAIN MIX OUTPUT

These stereo outputs are supplied with both the XLR and 1/4" phone jacks and it is controlled by the Main Mix level.

CONTROL ELEMENTS

17- CTRL OUT JACKS

These 1/4" phone jacks will be used to send the Control Room signal to the studio monitor speakers or a second set of PA.

18- PHONES JACKS

This jack will be used to send the signal to a pair of headphone or to powered studio monitors.

19- TALKBACK INPUT

This input is for a talkback microphone, that will be managed by TALKBACK Section.

20- POWER SWITCH

This switch is used to turn the main power on and off.

21- AC INLET with FUSE HOLDER.

Use it to connect your MX24.4/32.4 to the main AC with the supplied AC cord. Please check voltage available in your country and how the voltage for your MX24.4/32.4 is configured before attempting to connect to main AC.

22- CENTER JACK

This 1/4" phone jack is used to send out the signal from CENTER Bus to Main MIX, and it is controlled by CENTER Fader.

23- MATRIX JACKS

These two balanced TRS jacks are for MATRIX A & B output.

OPTIONAL MODULES

OPTION MODULES SECTION

MX24.4/32.4 offer two positions for modules assemblage, meanwhile there are three selected modules, of which you can select two or one or none. On the right of the front panel there are two pieces module covers. Open the top module panel cover, you can see there are three interfaces. The left one is EQ MOD module interface, the middle one is DSP module interface and the right one is MP3 player module interface.

(DO NOT MISTAKE THE CONNECTOR INTERFACE, OR IT WILL DESTROY YOUR MODULES AND MIXER)

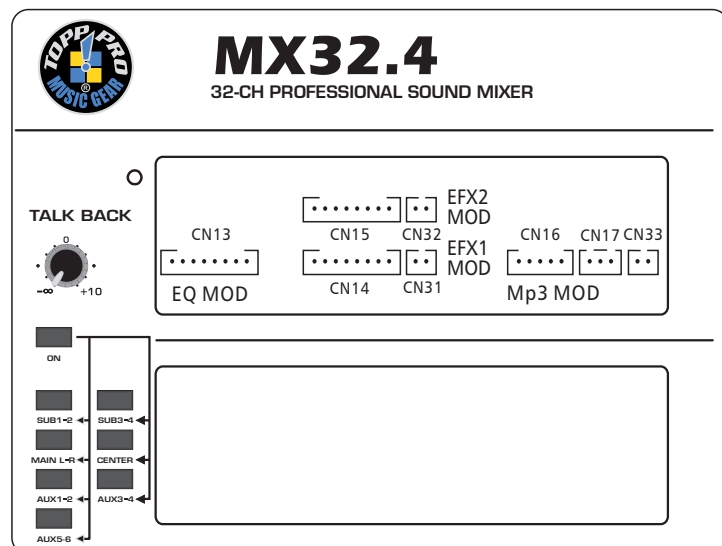

OPTIONAL MODULES

Note: MX24.4/32.4 can simultaneously install two kinds of option modules. Two DSP modules can be at same time installed together, while the EQ module and USB modules are not allowed to take such operations.

9-band EQ module install

Take out the short circuit wire which connects 9-band EQ module interface. Plug in the 9-band EQ module connection wire to the EQMOD CONNECTOR. Fix the 9-band EQ module at one of the two module places with the two attached screws (Safekeeping the short circuit wire. Put the short circuit wire back into the EQ MOD CONNECTOR when you take out the 9-band EQ module, or the output will be cut)

function

1- EQ Switch

Engage this button to add the stereo graphic EQ to the main mix output circuit. It can be used to modify the frequency "contour" of a sound. If you release the button, the stereo graphic EQ will be bypassed

2- STEREO GRAPHIC EQ

Each one of these faders will boost or attenuate (+/-12 dB) the selected frequency at a preset bandwidth. When all the faders are in the center position, the output of the equalizer is flat response.

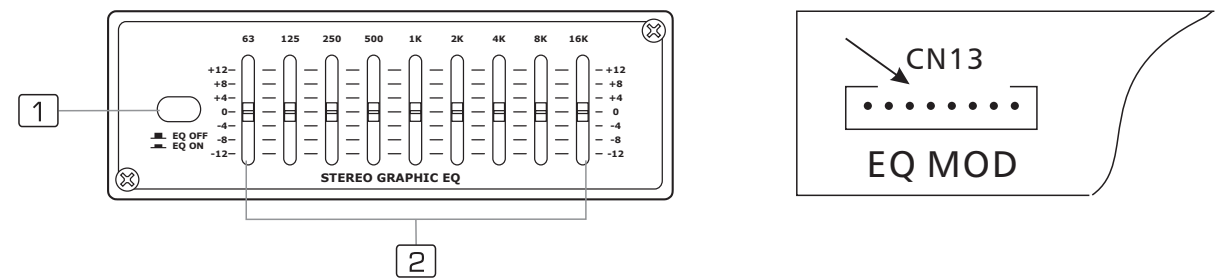

DSP module install

Take out the short circuit wire which connects DSP module interface. Plug in the DSP module connection wire into DSPMOD CONNECTOR. Fix the DSP module panel at one of the two module places with the two attached screws (Safekeeping the short circuit wire. Put the short circuit wire back into the DSPMOD CONNECTOR when you take out the DSP module, or it will make distortion)

