

# Owner's Manual

Acoustic Amplifier

*Acoustic Singer*



Acoustic Singer Live  
ACS-LIVE



Acoustic Singer Pro  
ACS-PRO

## Main Features

Acoustic Singer is an amp that's designed to let the singer-instrumentalist perform powerfully on acoustic guitar and vocals.

- Independent mic and guitar channels are provided, and can be mixed.
- A newly developed two-way speaker is bi-amped to deliver clear and powerful sound.
- You can automatically add harmony to your vocal along with your guitar performance.
- The mix of your vocal and guitar sound can be recorded and used for loop performances.
- Independent effects are provided for the mic channel and guitar channel.

MIC channel	Anti-feedback, delay/echo, reverb
GUITAR channel	Acoustic resonance, anti-feedback, chorus reverb

- A tweeter attenuator button is provided to deliver a milder sound.
- An AUX input allows you to connect your audio player or other audio source, and the line output can be connected to your PA system.

English

日本語

Deutsch

Français

Italiano

Español

Português



Nederlands



# USING THE UNIT SAFELY

Before using this unit, carefully read the sections entitled “**IMPORTANT SAFETY INSTRUCTIONS**” (inside front cover), “**USING THE UNIT SAFELY**” (p. 2), and “**IMPORTANT NOTES**” (p. 3). These sections provide important information concerning the proper operation of the unit. Additionally, in order to feel assured that you have gained a good grasp of every feature of your new unit, read Owner’s Manual in its entirety. This manual should be saved and kept on hand as a convenient reference.







Copyright © 2016 ROLAND CORPORATION

## INSTRUCTIONS FOR THE PREVENTION OF FIRE, ELECTRIC SHOCK, OR INJURY TO PERSONS

About  **WARNING** and  **CAUTION** Notices

 <b>WARNING</b>	Used for instructions intended to alert the user to the risk of death or severe injury should the unit be used improperly.
 <b>CAUTION</b>	Used for instructions intended to alert the user to the risk of injury or material damage should the unit be used improperly. * Material damage refers to damage or other adverse effects caused with respect to the home and all its furnishings, as well to domestic animals or pets.

About the Symbols

	The  symbol alerts the user to important instructions or warnings. The specific meaning of the symbol is determined by the design contained within the triangle. In the case of the symbol at left, it is used for general cautions, warnings, or alerts to danger.
	The  symbol alerts the user to items that must never be carried out (are forbidden). The specific thing that must not be done is indicated by the design contained within the circle. In the case of the symbol at left, it means that the unit must never be disassembled.
	The  symbol alerts the user to things that must be carried out. The specific thing that must be done is indicated by the design contained within the circle. In the case of the symbol at left, it means that the power-cord plug must be unplugged from the outlet.

### ALWAYS OBSERVE THE FOLLOWING

#### **WARNING**

##### **Make sure that the power cord is grounded**

Connect mains plug of this model to a mains socket outlet with a protective earthing connection.



##### **To completely turn off power to the unit, pull out the plug from the outlet**

Even with the power switch turned off, this unit is not completely separated from its main source of power. When the power needs to be completely turned off, turn off the power switch on the unit, then pull out the plug from the outlet. For this reason, the outlet into which you choose to connect the power cord’s plug should be one that is within easy reach and readily accessible.



##### **Secure a sufficient amount of space at the setup location**

Since this unit normally emits a slight amount of heat, make sure to secure sufficient space around it, as shown below.

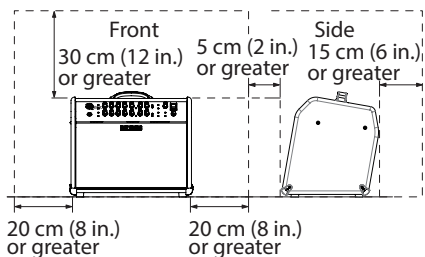

##### **Do not disassemble or modify by yourself**

Do not carry out anything unless you are instructed to do so in the owner’s manual. Otherwise, you risk causing malfunction.



##### **Do not repair or replace parts by yourself**

Refer all servicing to your retailer, the nearest Roland Service Center, or an authorized Roland distributor, as listed on the “Information.”



#### **WARNING**

##### **Do not use or store in the following types of locations**

- Subject to temperature extremes (e.g., direct sunlight in an enclosed vehicle, near a heating duct, on top of heat-generating equipment); or are
- Damp (e.g., baths, washrooms, on wet floors); or are
- Exposed to steam or smoke; or are
- Subject to salt exposure; or are
- Exposed to rain; or are
- Dusty or sandy; or are
- Subject to high levels of vibration and shakiness; or are
- Placed in a poorly ventilated location.



##### **Do not place in an unstable location**

Otherwise, you risk injury as the result of the unit toppling over or dropping down.



##### **Connect the power cord to an outlet of the correct voltage**

The unit should be connected to a power supply only of the type described as marked on the rear side of unit.



##### **Use only the supplied power cord**

Use only the attached power cord. Also, the supplied power cord must not be used with any other device.



##### **Do not bend the power cord or place heavy objects on it**

Otherwise, fire or electric shock may result.



##### **Avoid extended use at high volume**

Use of the unit at high volume for extended periods of time may cause hearing loss. If you ever experience any hearing loss or ringing in the ears, you should immediately stop using the unit and consult a specialized physician.



#### **WARNING**

##### **Do not allow foreign objects or liquids to enter unit; never place containers with liquid on unit**

Do not place containers containing liquid (e.g., flower vases) on this product. Never allow foreign objects (e.g., flammable objects, coins, wires) or liquids (e.g., water or juice) to enter this product. Doing so may cause short circuits, faulty operation, or other malfunctions.



##### **Turn off the unit if an abnormality or malfunction occurs**

Immediately turn the unit off, remove the power cord from the outlet, and request servicing by your retailer, the nearest Roland Service Center, or an authorized Roland distributor, as listed on the “Information” when:



- The power cord has been damaged; or
- If smoke or unusual odor occurs; or
- Objects have fallen into, or liquid has been spilled onto the unit; or
- The unit has been exposed to rain (or otherwise has become wet); or
- The unit does not appear to operate normally or exhibits a marked change in performance.

##### **Be cautious to protect children from injury**

Always make sure that an adult is on hand to provide supervision and guidance when using the unit in places where children are present, or when a child will be using the unit.



##### **Do not drop or subject to strong impact**

Otherwise, you risk causing damage or malfunction.



##### **Do not share an outlet with an unreasonable number of other devices**

Otherwise, you risk overheating or fire.



##### **Do not use overseas**

Before using the unit in overseas, consult with your retailer, the nearest Roland Service Center, or an authorized Roland distributor, as listed on the “Information.”



The ventilation should not be impeded by covering the ventilation openings with items such as newspaper, table-cloths, curtains etc.



No naked flame sources such as lighted candles should be placed on the apparatus.



Use the apparatus in moderate climates.



**CAUTION**

**When disconnecting the power cord, grasp it by the plug**

To prevent conductor damage, always grasp the power cord by its plug when disconnecting it.



**Periodically clean the power plug**

An accumulation of dust or foreign objects between the power plug and the power outlet can lead to fire or electric shock.



At regular intervals, be sure to pull out the power plug, and using a dry cloth, wipe away any dust or foreign objects that may have accumulated.

**Disconnect the power plug whenever the unit will not be used for an extended period of time**

Fire may result in the unlikely event that a breakdown occurs.



**Route all power cords and cables in such a way as to prevent them from getting entangled**

Injury could result if someone were to trip on a cable and cause the unit to fall or topple.



**CAUTION**

**Avoid climbing on top of the unit, or placing heavy objects on it**

Otherwise, you risk injury as the result of the unit toppling over or dropping down.



**Never connect/disconnect a power plug if your hands are wet**

Otherwise, you could receive an electric shock.



**Disconnect all cords/cables before moving the unit**

Before moving the unit, disconnect the power plug from the outlet, and pull out all cords from external devices.



**Before cleaning the unit, disconnect the power plug from the outlet**

If the power plug is not removed from the outlet, you risk receiving an electric shock.



**CAUTION**

**Whenever there is a threat of lightning, disconnect the power plug from the outlet**

If the power plug is not removed from the outlet, you risk causing malfunction or receiving an electric shock.



**Precautions concerning use of phantom power supply**

Always turn the phantom power off when connecting any device other than condenser microphones that require phantom power. You risk causing damage if you mistakenly supply phantom power to dynamic microphones, audio playback devices, or other devices that don't require such power. Be sure to check the specifications of any microphone you intend to use by referring to the manual that came with it. (This instrument's phantom power: 48 V DC, 14 mA Max)



**Do not remove the speaker grille and speaker**

Do not remove the speaker grille and speaker by any means. Speaker is not user replaceable. Shock hazardous voltages and currents are present inside the enclosure.



# IMPORTANT NOTES

## Power Supply

- Do not connect this unit to same electrical outlet that is being used by an electrical appliance that is controlled by an inverter or a motor (such as a refrigerator, washing machine, microwave oven, or air conditioner). Depending on the way in which the electrical appliance is used, power supply noise may cause this unit to malfunction or may produce audible noise. If it is not practical to use a separate electrical outlet, connect a power supply noise filter between this unit and the electrical outlet.

## Placement

- Using the unit near power amplifiers (or other equipment containing large power transformers) may induce hum. To alleviate the problem, change the orientation of this unit; or move it farther away from the source of interference.
- This unit may interfere with radio and television reception. Do not use this unit in the vicinity of such receivers.
- Noise may be produced if wireless communications devices, such as cell phones, are operated in the vicinity of this unit. Such noise could occur when receiving or initiating a call, or while conversing. Should you experience such problems, you should relocate such wireless devices so they are at a greater distance from this unit, or switch them off.
- Do not allow lighting devices that normally are used while their light source is very close to the unit (such as a piano light), or powerful spotlights to shine upon the same area of the unit for extended periods of time. Excessive heat can deform or discolor the unit.
- When moved from one location to another where the temperature and/or humidity is very different, water droplets (condensation) may form inside the unit. Damage or malfunction may result if you attempt to use the unit in this condition. Therefore, before using the unit, you must allow it to stand for several hours, until the condensation has completely evaporated.

- Do not paste stickers, decals, or the like to this instrument. Peeling such matter off the instrument may damage the exterior finish.
- Depending on the material and temperature of the surface on which you place the unit, its rubber feet may discolor or mar the surface.
- Do not place containers or anything else containing liquid on top of this unit. Also, whenever any liquid has been spilled on the surface of this unit, be sure to promptly wipe it away using a soft, dry cloth.

## Maintenance

- To clean the unit, use a dry, soft cloth; or one that is slightly dampened. Try to wipe the entire surface using an equal amount of strength, moving the cloth along with the grain of the wood. Rubbing too hard in the same area can damage the finish.
- Never use benzine, thinners, alcohol or solvents of any kind, to avoid the possibility of discoloration and/or deformation.

## Repairs and Data

- Before sending the unit away for repairs, be sure to make a backup of the data stored within it; or you may prefer to write down the needed information. Although we will do our utmost to preserve the data stored in your unit when we carry out repairs, in some cases, such as when the memory section is physically damaged, restoration of the stored content may be impossible. Roland assumes no liability concerning the restoration of any stored content that has been lost.

## Additional Precautions

- Roland assumes no liability concerning the restoration of any stored content that has been lost.
- Use a reasonable amount of care when using the unit's buttons, sliders, or other controls; and when using its jacks and connectors. Rough handling can lead to malfunctions.
- When disconnecting all cables, grasp the connector itself—never pull on the cable. This way you will avoid causing shorts, or damage to the cable's internal elements.

- A small amount of heat will radiate from the unit during normal operation.
- To avoid disturbing others nearby, try to keep the unit's volume at reasonable levels.
- Do not use connection cables that contain a built-in resistor.

## Intellectual Property Right

- It is forbidden by law to make an audio recording, video recording, copy or revision of a third party's copyrighted work (musical work, video work, broadcast, live performance, or other work), whether in whole or in part, and distribute, sell, lease, perform or broadcast it without the permission of the copyright owner.
- Do not use this product for purposes that could infringe on a copyright held by a third party. We assume no responsibility whatsoever with regard to any infringements of third-party copyrights arising through your use of this product.
- Roland and BOSS are either registered trademarks or trademarks of Roland Corporation in the United States and/or other countries.
- ASIO is a trademark and software of Steinberg Media Technologies GmbH.
- This product contains eParts integrated software platform of eSOL Co., Ltd. eParts is a trademark of eSOL Co., Ltd. in Japan.
- Company names and product names appearing in this document are registered trademarks or trademarks of their respective owners.

# Panel Description

## Front Panel

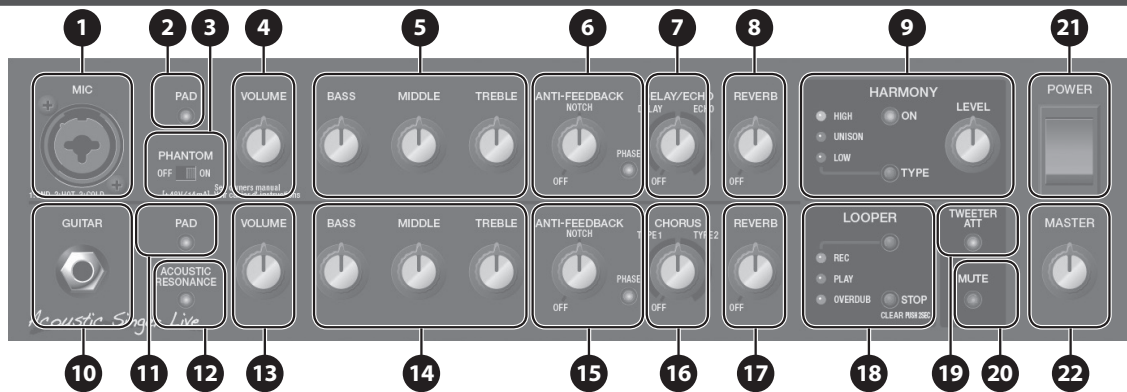

## Mic Channel (Upper Row)

This is the channel for connecting a vocal mic.

### 1 MIC jack

Connect your mic here.

\* Pin assignment of MIC jack

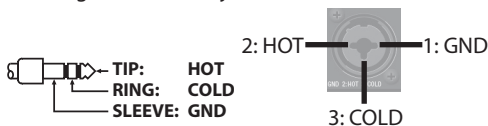

### 2 [PAD] button

Use this if the input level of the MIC jack is excessive, or if the sound is distorted. When the button is pressed, the input level is attenuated by 15 dB, and the button is lit green.

### 3 [PHANTOM] switch

Supplies phantom power. Turn this ON if you connect a condenser mic that requires a phantom power supply.

### 4 [VOLUME] knob

Adjusts the volume.

### 5 EQUALIZER

#### [BASS] knob

Adjusts the sound level of the low-frequency range.

#### [MIDDLE] knob

Adjusts the sound level of middle-frequency range.

#### [TREBLE] knob

Adjusts the sound level of the high-frequency range.

### 6 ANTI-FEEDBACK

#### [PHASE] button

If acoustic feedback is a problem, first try pressing the [PHASE] button. Switching the phase will help suppress acoustic feedback.

#### [NOTCH] knob

If turning on the [PHASE] button does not help, adjust the [NOTCH] knob.

- While acoustic feedback is occurring, turn the [NOTCH] (frequency) knob to find the location at which feedback is suppressed.
- Turning the knob toward the right suppresses feedback at a higher frequency; turning the knob toward the left suppresses feedback at a lower frequency.

### 7 [DELAY/ECHO] knob

Applies delay/echo to the audio that is input from the MIC jack. Turn the knob to adjust the depth of the effect.

\* Either DELAY or ECHO is selected depending on the position of the knob.

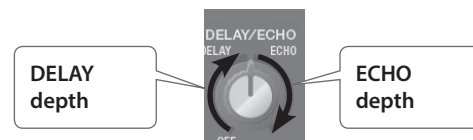

Type	Effect
DELAY	Produces an echo-like effect.
ECHO	Produces a distinctively spacious effect similar to a tape echo unit.

### 8 [REVERB] knob

Adjusts the reverb depth.

### 9 HARMONY

Lets you add natural harmony to the audio that is input from the MIC jack.

#### [LEVEL] knob

Adjusts the volume of the harmony.

#### [ON] button

Switches HARMONY on/off.

#### [TYPE] button

Selects the type of harmony. The type switches each time you press the button.

Type	Explanation
HIGH	Adds harmony above the vocal sound that is input.
UNISON	Simulates the doubling effect produced when a vocalist records the same melody a second time, adding richness to the sound.
LOW	Adds harmony below the vocal sound that is input.

\* You can specify the reference pitch used when the harmony is added. For details, refer to "**Specifying the Harmony Reference Pitch**" (p. 8).

## Guitar Channel (Lower Row)

This is the channel for connecting a guitar, such as an acoustic-electric guitar.

### 10 GUITAR jack

Connect your guitar here. You can connect any guitar that is equipped with a pickup.

### 11 [PAD] button

Use this if the input level of the GUITAR jack is excessive. When the button is pressed, the input level is attenuated by 10 dB, and the button is lit green.

### 12 [ACOUSTIC RESONANCE] button

Adds the natural resonance of an acoustic guitar.

The setting changes in the following order each time you press the button.

Button	Explanation
Green	A full sound with emphasized body resonance
Orange	A bright sound with boosted mid-range resonance
Red	A brilliant sound extending to the high range
Unlit	Off

### 13 [VOLUME] knob

Adjusts the volume.

### 14 EQUALIZER

#### [BASS] knob

Adjusts the sound level of the low-frequency range.

#### [MIDDLE] knob

Adjusts the sound level of middle-frequency range.

#### [TREBLE] knob

Adjusts the sound level of the high-frequency range.

### 15 ANTI-FEEDBACK

#### [PHASE] button

If acoustic feedback is a problem, first try pressing the [PHASE] button. Switching the phase will help suppress acoustic feedback.

#### [NOTCH] knob

If turning on the [PHASE] button does not help, adjust the [NOTCH] knob.

- While acoustic feedback is occurring, turn the [NOTCH] (frequency) knob to find the location at which feedback is suppressed.
- Turning the knob toward the right suppresses feedback at a higher frequency; turning the knob toward the left suppresses feedback at a lower frequency.

### 16 [CHORUS] knob

Applies a chorus effect to the sound that is input from the GUITAR jack. Turn the knob to adjust the depth of the effect.

\* Either TYPE1 or TYPE2 is selected depending on the position of the knob.

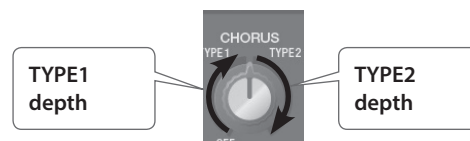

Type	Effect
TYPE1	Chorus with natural modulation.
TYPE2	Chorus with emphasized modulation.

### 17 [REVERB] knob

Adjusts the reverb depth.

### 18 LOOPER

You can record up to 40 seconds (MONO) of a performance and play back the recorded section over and over. You can also layer additional performances with the recording as it plays back (overdubbing). This lets you create real-time backing performances on the fly.

\* For more about how to operate the looper, refer to "Using the Looper" (p. 9).

#### [LOOPER] button

Switches between recording, loop playback, and overdubbing.

#### [STOP] button

Stops recording or playback.

#### REC/PLAY/OVERDUB indicator

Indicates the status of the looper.

## Common to Both Channels

### 19 [TWEETER ATT] button

Applies a filter to the high-frequency region, making the sound milder. If this is on, the button is lit green. This is effective in cases such as when you want the guitar strings to sound softer and more natural.

### 20 [MUTE] button

You can mute the sound while leaving the unit powered-on. This lets you mute the amp without changing the volume or other settings when you leave the stage, such as between sets of your live performance.

\* The sound of the PHONES/REC OUT jack is not muted.

\* The sound from the AUX jack that is output to the DI/LINE OUT jacks is not muted.

### 21 [POWER] switch

Turns the power of the Acoustic Singer on/off.

### 22 [MASTER] knob

Adjusts the overall volume.



## Rear Panel

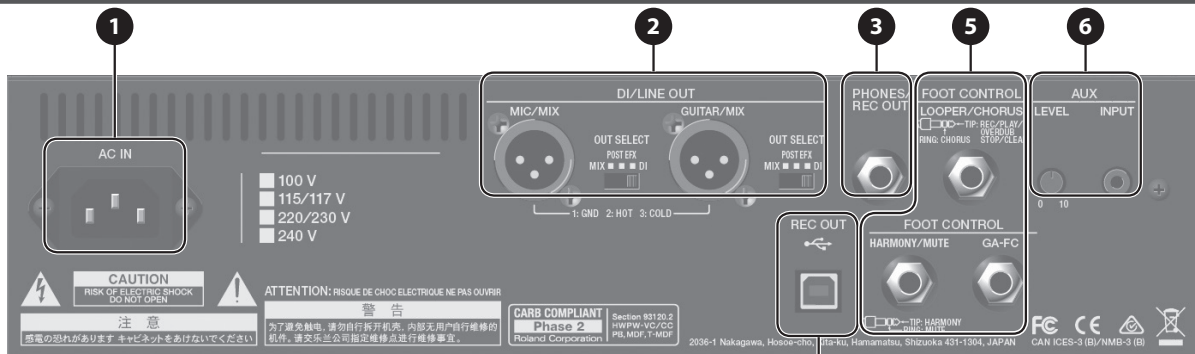

\* To prevent malfunction and equipment failure, always turn down the volume, and turn off all the units before making any connections.

### 1 AC IN jack

Connect the included power cord.

\* Use only the power cord that was included with the unit.

### 2 DI/LINE OUT

Connect this to your PA system or recorder.

You can use this in conjunction with an external PA system, or to record your performance via direct line while monitoring the sound from this unit.

Adjust the output level using the **[VOLUME]** knob of each channel.

#### MIC/MIX jack

From this jack, the audio that is input from the MIC jack can be output by itself, or mixed with the audio that is input from the GUITAR jack.

#### GUITAR/MIX jack

From this jack, the audio that is input from the GUITAR jack can be output by itself, or mixed with the audio that is input from the MIC jack.

\* Pin assignment of MIC/MIX jack and GUITAR/MIX jack

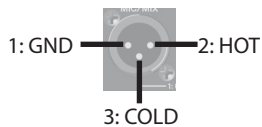

#### [OUT SELECT] switch

Specifies the output of the MIC/MIX jack and GUITAR/MIX jack.

Setting	Explanation
MIX	The inputs from the MIC jack and the GUITAR jack pass through the effects of the respective channel, and are then mixed and output. The input from the AUX jack is also mixed and output.
POST EFX	The inputs from the MIC jack and the GUITAR jack pass through the effects of the respective channel, and are then output separately from the MIC/MIX jack and the GUITAR/MIX jack.
DI	The inputs from the MIC jack and GUITAR jack do not pass through the effects, but are output separately from the MIC/MIX jack and the GUITAR/MIX jack.

### 3 PHONES/REC OUT jack

Connect headphones here. To adjust the volume, use the **[VOLUME]** knob along with the **[MASTER]** knob.

\* If a plug is inserted in this jack, no sound will be output from the Acoustic Singer's own speaker. This is convenient if you don't want loud sound to be produced from the speaker, such as when you're practicing at night.

### 4 REC OUT jack

You can use a commercially available USB 2.0 cable to record the sound of the Acoustic Singer into your computer.

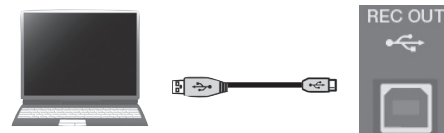

**You must install the USB driver when connecting the unit to your computer.**

Download the USB driver from the BOSS website. For details, refer to Readme.htm which is included in the download.

[www.boss.info/support/](http://www.boss.info/support/)

## 5 FOOT CONTROL

If you connect a footswitch (sold separately: BOSS FS-6, FS-7, or FS-5U), you can use your foot to control LOOPER operations (p. 9) or turn CHORUS, HARMONY, and MUTE on/off.

\* Pin assignment of LOOPER/CHORUS jack, HARMONY/MUTE jack, and GA-FC jack.

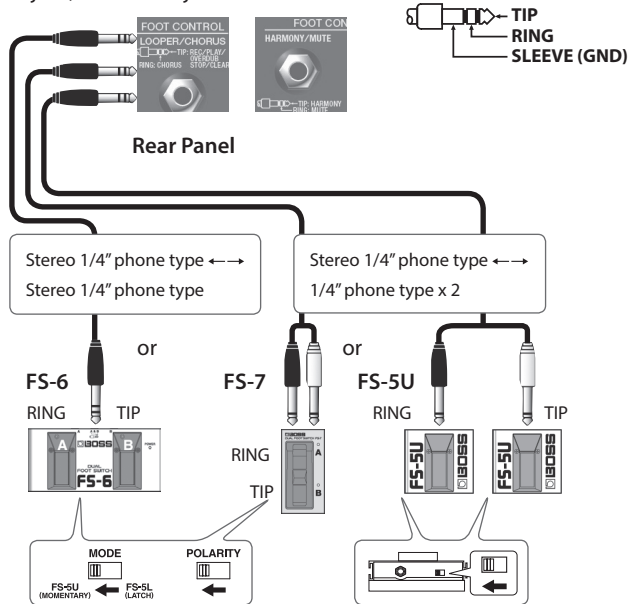

### If connected to the LOOPER/CHORUS jack

Switch		Explanation
TIP	LOOPER	Operates LOOPER (p. 9).
RING	CHORUS	Turns CHORUS (p. 5) on/off.

### If connected to the HARMONY/MUTE jack

Switch		Explanation
TIP	HARMONY	Turns HARMONY (p. 4) on/off.
RING	MUTE	Turns MUTE (p. 5) on/off.

### GA-FC jack

You can connect a GA-FC (sold separately) and turn on/off the following.

DELAY/ECHO and REVERB of the mic channel,  
CHORUS and REVERB of the guitar channel.  
HARMONY, MUTE

#### Connecting the GA-FC

Connect a stereo cable to the GA-FC jack.

\* Always use a stereo cable.

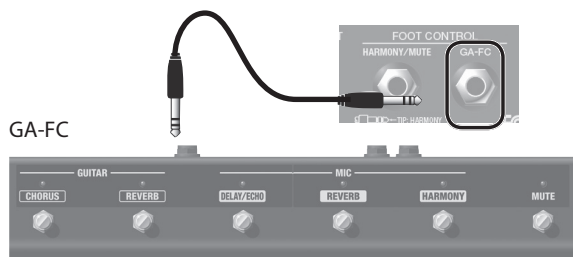

### Using the GA-FC

You can switch on/off the REVERB of each channel, DELAY/ECHO, HARMONY, and MUTE.

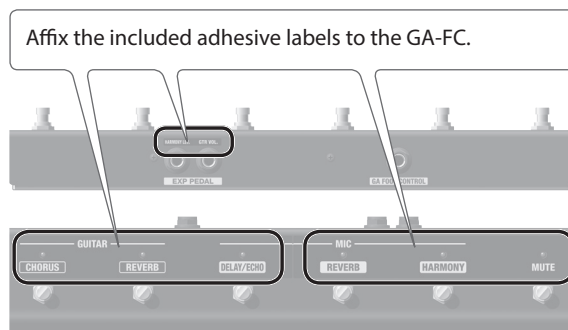

### Using the expression pedals

If you connect an expression pedal (sold separately: Roland EV-5, BOSS FV-500L, BOSS FV-500H), you can use the pedal to vary the volume of the guitar channel or control the volume of the HARMONY effect.

\* Use only the specified expression pedal. By connecting any other expression pedals, you risk causing malfunction and/or damage to the unit.



Expression Pedal

Jack	Explanation
GTR VOL.	Adjusts the volume of the guitar channel.
HARMONY LEV.	Controls the HARMONY volume.

### Setting MINIMUM VOLUME of an expression pedal

With the [MINIMUM VOLUME] knob of an expression pedal, you can set the value for when the pedal is lifted up all the way (lowest value).

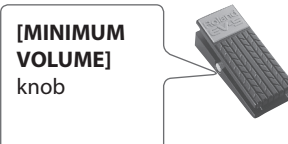

## 6 AUX

You can connect a CD player, audio player, or electronic musical instrument, and hear it play along with your own performance.

### INPUT jack

Connect your CD player, audio player, or electronic musical instrument here.

### [LEVEL] knob

Adjusts the volume of the connected instrument.

## Turning the Power On/Off

\* Once everything is properly connected (p. 6), be sure to follow the procedure below to turn on their power. If you turn on equipment in the wrong order, you risk causing malfunction or equipment failure.

**1. Make sure that the Acoustic Singer's [MASTER] knob and the volume of the devices connected to the Acoustic Singer are set to 0.**

**2. Turn on the Acoustic Singer.**

\* Before turning the unit on/off, always be sure to turn the volume down. Even with the volume turned down, you might hear some sound when switching the unit on/off. However, this is normal and does not indicate a malfunction.



**3. Turn on the power of the devices connected to the LINE OUT jack, PHONES jack, and REC OUT ↔ port.**

**4. Use each channel's [VOLUME] knob and [MASTER] knob to adjust the volume of the Acoustic Singer.**

**5. Adjust the volume levels for the connected devices.**

Before switching off the power, lower the volume on each of the devices in your system and then TURN OFF the devices in the reverse order to which they were switched on.

\* If you need to turn off the power completely, first turn off the unit, then unplug the power cord from the power outlet. Refer to **"To completely turn off power to the unit, pull out the plug from the outlet"** (p. 2).

## Specifying the Harmony Reference Pitch

Here's how to specify the reference pitch that is used when adding harmony. Match this reference pitch to the tuning of your guitar or other accompaniment instrument.

**1. Long-press the [TYPE] button.**

The Acoustic Singer is in harmony reference pitch setting mode.



**2. Use the [TYPE] button to select a reference pitch.**

Each time you press the button, you'll cycle through the following settings in the order of 1-7.

	Indicator	Explanation
1	UNISON lit	440 Hz (factory setting)
2	UNISON+HIGH lit	441 Hz
3	UNISON+HIGH blinking	442 Hz
4	HIGH blinking	443 Hz
5	UNISON+LOW lit	439 Hz
6	UNISON+LOW blinking	438 Hz
7	LOW blinking	437 Hz

**3. Long-press the [TYPE] button to exit reference pitch setting mode.**

\* This setting is remembered even when the power is switched off. When you switch on the power and enter reference pitch setting mode, the currently specified setting (1-7 listed above) is shown.





## Using the Looper

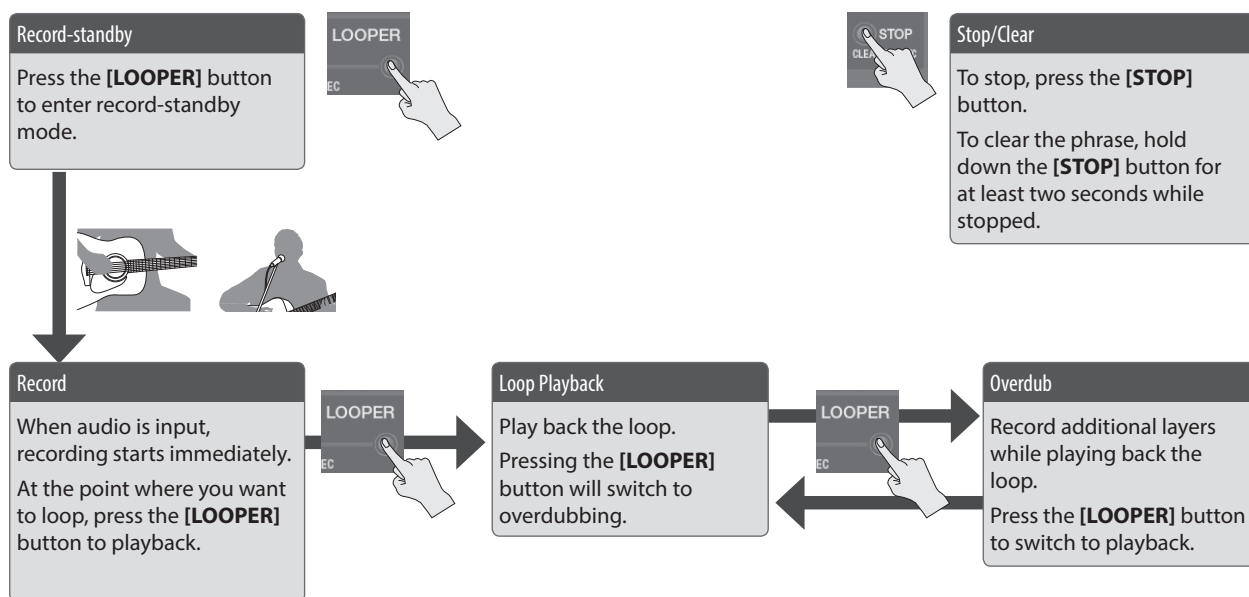

### REC/PLAY/OVERDUB indicator status



Indicator	Explanation
REC	Blinking while in record-standby, lit while recording.
PLAY	Lit while playing back.
OVERDUB	Lit while overdubbing.

## Looper operations using a footswitch

You can also operate the looper by using a footswitch (sold separately: FS-5U, FS-6, FS-7).

- If a footswitch is connected, recording starts not when audio is input but when you press the footswitch (TIP). Playback and overdubbing operations are the same as when using the **[LOOP]** button.
- If you press the footswitch (TIP) twice within one second, the looper stops.
- If you hold down the footswitch (TIP) for two seconds or longer, the phrase is cleared.

# Main Specifications

## BOSS Acoustic Singer Pro: Acoustic Amp

## BOSS Acoustic Singer Live: Acoustic Amp

	Acoustic Singer Live	Acoustic Singer Pro
<b>Rated Power Output</b>	60 W (Woofer: 50 W, Tweeter: 10 W)	120 W (Woofer: 100 W, Tweeter: 20 W)
<b>Nominal Input Level</b>	MIC INPUT: -33 dBu (2.5 k Ω) GUITAR INPUT: -10 dBu (5 M Ω) AUX INPUT: -8 dBu (10 k Ω)	
<b>Speaker</b>	16 cm (6.5 inches) Woofer x 1, 2.5 cm (1 inch) Dome Tweeter x 1	20 cm (8 inches) Woofer x 1, 2.5 cm (1 inch) Dome Tweeter x 1
<b>Connectors</b>	MIC jack: Combo type (XLR, 1/4-inch TRS phone type) GUITAR jack: 1/4-inch phone type AUX IN jack: Stereo miniature phone type PHONES/REC OUT jack: Stereo 1/4-inch phone type DI/LINE OUT MIC/MIX jack: XLR type DI/LINE OUT GUITAR/MIX jack: XLR type FOOT CONTROL LOOPER/CHORUS jack: 1/4-inch TRS phone type FOOT CONTROL HARMONY/MUTE jack: 1/4-inch TRS phone type GA-FC jack: 1/4-inch TRS phone type USB port: USB B type AC IN jack	
<b>Power Consumption</b>	40 W	50 W
<b>Dimensions</b>	367 (W) x 274 (D) x 314 (H) mm 14-1/2 (W) x 10-13/16 (D) x 12-3/8 (H) inches	417 (W) x 330 (D) x 358 (H) mm 16-7/16 (W) x 13 (D) x 14-1/8 (H) inches
<b>Weight</b>	10.5 kg 23 lbs 3 oz	14.5 kg 32 lbs oz
<b>Accessories</b>	Owner's manual Power cord GA-FC sticker	

\* 0 dBu = 0.775 Vrms

\* This document explains the specifications of the product at the time that the document was issued. For the latest information, refer to the Roland website.

# Block Diagram

